

For quick simple questions you can contact us via **Telegram**.
The official technical support channel **@SMC5TechSupport** (<https://t.me/SMC5TechSupport>).
Available online Mon-Fri 8:00-16:00 UTC.

8SMC4-USB User Manual

1. About
 1. General information
 2. Benefits
 3. Table of specifications
 4. Specifications
 5. Multi-axis system specifications
2. Safety instructions
3. Overview and getting started
 1. One axis configuration
 2. Multi-axis configuration
 1. Errata
 3. Example of a motor connection
 4. Manual profile setting
 5. Calculation of the nominal current
 6. Possible problems and solutions
4. Technical specification
 1. Appearance and connectors
 1. Controller board
 2. One axis system
 3. Two axes system
 4. Multi-axis system
 2. Kinematics and rotation modes
 1. Predefined speed rotation mode
 2. Rotation for predefined point
 3. Predefined displacement mode
 4. Acceleration mode
 5. Backlash compensation
 6. Rotation reversal
 7. Recommendations for accurate rotation
 8. PID-algorithm for DC engine control
 9. Stop motion modes
 3. Main features
 1. Supported motor types
 2. Motor limiters
 3. Limit switches
 4. Automatic Home position calibration
 5. Operation with encoders
 6. Revolution sensor
 7. Steps loss detection
 8. Power control
 9. Critical parameters
 10. Saving the parameters in the controller flash memory
 11. User defined position units
 4. Safe operation
 5. Additional features
 1. Operating modes indication
 2. Operations with magnetic brake
 3. Joystick control
 4. Left-Right buttons control
 5. TTL synchronization
 6. Design of multi-axis system
 7. General purpose digital input-output
 8. General purpose analog input
 9. External driver control interface
 10. Serial port
 11. Saving the position in controller's FRAM memory
 12. The Standa stages detection
 6. Secondary features
 1. Zero position adjustment
 2. User-defined position adjustment
 3. Controller status
 4. USB connection autorecovery
 7. Software compatibility
 1. MicroManager
 2. TANGO
5. XILab application User's guide
 1. About XILab
 2. Main windows of the XILab application

1. XILab Start window
2. XILab Main window in single-axis control mode
3. XILab Main window in multi-axis control mode
4. Application Settings
5. Charts
6. Scripts
7. XiLab Log
3. Controller Settings
 1. Settings of kinematics (Stepper motor)
 2. Motion range and limit switches
 3. Critical board ratings
 4. Power consumption settings
 5. Home position settings
 6. Synchronization settings
 7. Brake settings
 8. Position control
 9. Settings of external control devices
 10. UART settings
 11. General purpose input-output settings
 12. Motor type settings
 13. Settings of kinematics (DC motor)
 14. Settings of PID control loops
 15. About controller
4. XILab application settings
 1. XILab general settings
 2. General motor settings
 3. Attenuator settings
 4. Cyclical motion settings
 5. Log settings
 6. Charts general settings
 7. Charts customization
 8. User units settings
 9. About the application
5. Positioner specifications
 1. Positioner name
 2. Positioner general characteristics
 3. Motor characteristics
 4. Encoder specifications
 5. Hall sensor characteristics
 6. Reducing gear specifications
 7. Accessories specifications
6. Correct shutdown
7. Working over network
8. XILab installation
 1. Installation on Windows
 1. Installation on Windows XP
 2. Installation on Windows 7
 3. Installation on Windows 8
 2. Installation on Linux
 3. Installation on MacOS
6. Programming
 1. Programming guide
 1. Working with 8SMC4-USB in Labview
 2. Working with 8SMC4-USB in Matlab
 2. Communication protocol specification
 3. 8SMC1-USBhF software compatibility
 4. Libximc library timeouts
 5. XILab scripts
7. Files
 1. Configuration files
 1. Translation Stages
 1. 8MT160 - Motorized Delay Line
 2. 8MT295 - Long-Travel Motorized Linear Stages
 3. 8MT195 - Long-Travel Motorized Linear Stages
 4. 8MT167 - Motorized Translation Stage
 5. 8MT173 - Motorized Translation Stages
 6. 8MT173DC - Motorized Translation Stages
 7. 8MT50 - Motorized Translation Stages
 8. 8MT30 - Narrow Motorized Translation Stages
 9. 8MT175 - Motorized Translation Stages
 10. 8MT177 - Motorized Translation Stage
 11. 8MT184 - Motorized Translation Stage
 12. 8MT193 - Motorized Translation Stage
 13. 8MT200 - Motorized Translation Stages
 14. 8MTF - Motorized XY Scanning Stage
 15. 8MTF2 - Motorized Fiber Coupling Stage

-
- 16. [8MTFV - Motorized Translation Stage](#)
 - 17. [8MT60 - Motorized Translation Stage](#)
 - 2. [Rotation Stages](#)
 - 1. [8MR151 - Motorized Rotation Stages](#)
 - 2. [8MR170 - Motorized Rotation Stages](#)
 - 3. [8MR174 - Motorized Rotation Stage](#)
 - 4. [8MR190 - Motorized Rotation Stage](#)
 - 5. [8MR191 - Motorized Rotation Stage](#)
 - 6. [8MRB250 - Large Motorized Rotation Stage](#)
 - 7. [8MRU - Universal Motorized Rotation Stages](#)
 - 8. [8MPR16-1 - Motorized Polarizer Rotator](#)
 - 9. [8MRH240 - Large High Capacity Rotary Stage](#)
 - 3. [Vertical Translation Stages](#)
 - 1. [8MVT100 - Vertical Translation Stage](#)
 - 2. [8MVT120 - Vertical Translation Stage](#)
 - 3. [8MVT188 - Vertical Translation Stage](#)
 - 4. [8MVT40 - Vertical Translation Stage](#)
 - 5. [8MVT70 - Vertical Translation Stage](#)
 - 4. [Screws and actuators](#)
 - 1. [8MS00 - Motorized Screws](#)
 - 2. [8CMA06 - Motorized Actuator](#)
 - 3. [8CMA20 - Compact Motorized Actuator](#)
 - 4. [8CMA28 - Motorized Linear Actuator](#)
 - 5. [8CMA16DC - Motorized Linear Actuator](#)
 - 5. [Motorized Goniometers](#)
 - 1. [8MG00 - Motorized Goniometers](#)
 - 2. [8MG99 - Motorized Goniometer](#)
 - 6. [Mirror Mounts](#)
 - 1. [8MTOM2 - Motorized Two Axis Translation Optical Mount](#)
 - 2. [8MUP21 - Motorized Optical Mount](#)
 - 3. [8MBM24 - Motorized Mirror Mounts](#)
 - 4. [8MMA60 - Motorized Mirror Mounts](#)
 - 5. [8MBM57 - Large Aperture Motorized Mirror Mount](#)
 - 6. [8MKVDOM - Motorized Vertical drive optical mount](#)
 - 7. [Motorized Attenuators](#)
 - 1. [10MCWA168 - Motorised Closed Variable Wheel Attenuator](#)
 - 2. [10MWA168 - Motorized Variable Wheel Attenuator](#)
 - 8. [Motorized Iris Diaphragms](#)
 - 1. [8MID98 - Motorized Iris Diaphragm](#)
 - 2. [Software](#)
8. [Related products](#)
- 1. [Ethernet adapter](#)
 - 1. [Overview](#)
 - 2. [Administration](#)

1. About

1. [General information](#)
2. [Benefits](#)
3. [Table of specifications](#)
4. [Specifications](#)
5. [Multi-axis system specifications](#)

1.1. General information



Controller board.

We offer an inexpensive and ultra-compact servo-drive with USB interface for stepper motors with external power supply.

Forget about cumbersome and expensive servo-drives! All you need is a stepper motor, a controller, a USB cable and any stabilized external power supply. That is all! Forget about active coolers as well. Controller's board is about the same size as a notepad or a cellphone, therefore, you may just put it down on the worktable without any assembly procedures. The controller works with any type of compact stepper motors with the rated winding current of up to 3A. Controller works with stepper motors with no feedback as well as with ones equipped with encoders in feedback loop, including linear encoders on the stages. The motor connector on the controller board is the same as one used by Standa company and it fits to all the Standa stages. USB connector provides easy communication and work with computer. Several controllers can be connected to one computer either via USB ports or through a special backplane supplied with multiaxis systems. The controller is fully compatible with the majority of operating systems, e.g., Windows, Mac OS X, Linux, etc.

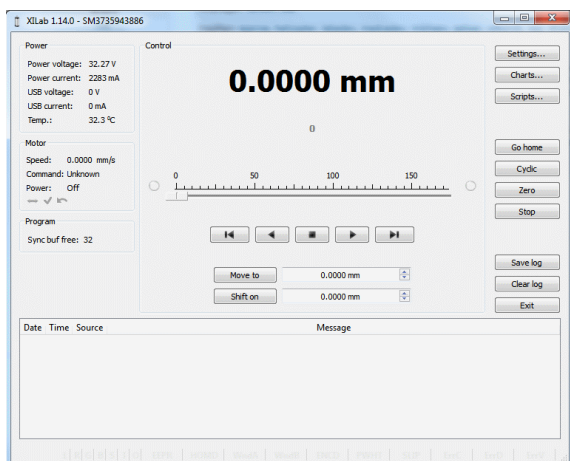

XILab main window.

All the necessary software including all configuration files are supplied with the controller. It allows you to start working with it the controller right out of the box, according to "plug-and-play" principle. We continuously develop additional configuration files for newly supported motors. Therefore, all you need is to download the file for your stage from [Configuration files](#) chapter, open it with XILab software and hit Apply. Your controller is now fully configured! Just issue movement commands and controller will do whatever you want.

8SMC4-USB controller is part of multi-axis 8SMC4-B36 system. It allows to control up to 36 DC, BLDC or stepper motors simultaneously. The chassis has 7U height and can be setup on usual 19" industrial cabinet or can be freestanding. Up to 50000 axis can be united via Ethernet. The system is automatically set on a peer-to-peer principle and does not require any special infrastructure or master servers.



Multi-axis configuration 8SMC4-B36.

8SMC4-B36 contains all necessary subsystems, including control, power units, cooling subsystems etc., which support the simultaneous work of all axes. Multi-axis system allows full hot plug: installation/replacement/removal of any controller module without stopping the system. 8SMC4-B36 is connected to a number of PC-based workstations via Ethernet, moreover all users have access to the range setting of the available axes and assignment of access privileges. From the programmer's point of view, work with all axes of the system is very similar to a local 8SMC4-USB box.

1.2. Benefits

Main benefits

- **Compact and powerful!** The controller's dimensions are 47x37x80mm including all connectors. The device is adapted to all stepper motors with rated winding current of up to 3A.
- **Compatible with 8SMC1-USBh** After updating the MicroSMC driver, all the software for 8SMC1-USBh will be working with 8SMC4-USB.
- **Compatible with all the Standa stages!** Have you got a Standa stage? Just plug and play, we have already done the rest for you!
- **It does remember all!** Do not worry about saving the current position on the computer: the controller does it itself using its own nonvolatile memory that works even after a sudden power cut.
- **It works with peripherals!** It supports a [quadrature encoder](#), [magnetic brake](#), a [joystick](#), [limit switches](#), a zero position sensor – all included, just plug and work!
- **Built-in zero calibration!** Using the [limit switches](#), the [revolution sensor](#), the [external signal](#) or their combination, the zero calibration is performed by a single [command](#)!
- **It works with all computers!** All the supplied software is compatible with [Windows 8](#), [Windows 7](#), Windows Vista, [Windows XP SP3](#), [Linux](#), [Mac OS X](#), including 64-bit versions.

All benefits

- **The most compact!** The controller's dimensions are 47x37x80mm including all connectors.
- **Really powerful!** It is adapted to all the stepper motors with rated winding current of up to 3A.
- **Compatible with 8SMC1-USBh** After updating the MicroSMC driver, all the software for 8SMC1-USBh will be working with 8SMC4-USB.
- **Compatible with all the Standa stages!** Have you got a Standa stage? Just plug and play, we have already done the rest for you!
- **It knows its own set!** A built-in feature for downloading the configuration file right from the stage memory is available! The stage's support of such memory is required.
- **Choose your interface!** Both USB and [serial port](#) are built-in and ready to use.
- **Really fast!** Up to 35,000 steps per second for any microstep mode!
- **Precise!** The microstep modes from full step to 1/256 of the step on all the speeds.
- **It does remember all!** Do not worry about saving the current position on the computer: the controller does it itself using its own nonvolatile memory that works even after a sudden power cut.
- **It works with peripherals!** It supports a [quadrature encoder](#), [magnetic brake](#), a [joystick](#), [limit switches](#), a zero position sensor – all included, just plug and work! Additional stabilized output for peripherals (5V, 100mA) is available.
- **Built-in zero calibration!** Using the [limit switches](#), the [revolution sensor](#), the [external signal](#) or their combination, the zero calibration is performed by a single [command](#)!
- **Stand-alone!** Would you like to work in the stand-alone mode? Just go ahead! An external [joystick](#), a [keypad](#) or their combination is supported.
- **Energy conserving!** Programmable current reduction in the motor windings in the hold mode with 1% accuracy.
- **Silent!** Smooth movement at lower speeds and no extra noise at higher speeds.
- **Protected!** An ESD protection on all pins of external connectors and additional short circuit protection for the motor windings.
- **Attentive!** It controls the temperature of the processor and the power driver as well as both currents and voltages for the power supply and USB.
- **Modern!** The firmware in the nonvolatile memory of the controller [can be updated](#) via USB interface.
- **Controlling and controllable!** The built-in [synch input and output](#) allow to start the rotation to desired position by the incoming external signal and/or to transmit the outgoing signal after the desired position is reached. The [analog common input](#) and the [digital common input/output](#) are built in as well.
- **Comprehensible!** The [status LED](#) displays the power supply and the controller's state. For convenience of use both signals doubled at the [external LEDs](#) as well as the state of the limit switches.
- **Multiaxis machine!** The multiaxis systems are designed by using standard USB hubs, either external or mounted at a special backplane. There may be up to 32 axis in the system.
- **It works with all computers!** All the supplied software is compatible with [Windows 8](#), [Windows 7](#), Windows Vista, [Windows XP SP3](#), [Linux](#), [Mac OS X](#), including 64-bit versions.
- **Examples for all programming languages!** Controllers are supplied with cross-platform library and examples which allow rapid development using C++, C#, .NET, Delphi, Visual Basic, gcc, Xcode, Matlab, Java and LabVIEW.
- **Full-featured interface!** The XILab user interface is supplied with the controller. It allows to easily control all the functions and features of the device without any programming.
- **Unique scripting language!** A scripting language is integrated into XILab software. It allows easy setting the sequence of actions, including cycles and branches, without compilation or learning any programming language.
- **New! Stepper motor close-loop control algorithm are ready!** Motion is smoother and faster than ever with innovation encoder based close-loop on 8SMC4-USB motor controllers. It combines advantages of BLDC motor control with cheapness of conventional stepper motors. No hidden catch, no stall or hitch, just free move!

1.3. Table of specifications

Power supply	external 12V - 36V DC
Current consumption	up to 5A (depending on the voltage) from external power supply, up to 400mA from USB
Current in the motor winding	up to 3A
Protection types	current overload protection, voltage overload protection, short circuit protection, motor hotplug/unplug protection
Motion modes	move left/right, move to point, shift on delta, continuous speed, acceleration and deceleration ramps, backlash compensation mode, automatic home position calibration mode
Step modes	full-step, 1/2, 1/4, 1/8, 1/16, 1/32, 1/64, 1/128, 1/256
Rotation speed	up to 35 000 full steps per second
Speed profile	trapezoidal
Position counter	40 bit
Feedback	quadrature encoder (optional)
Limit switches	2
Feedback bandwidth	200 kHz

Note: The controller's working voltage range is 12V to 36V DC. The voltage limits are 2V and 48V DC. If the voltage exceeds 48V, the controller is guaranteed to fail. If the voltage falls below 2V, the controller will be unable to rotate the motor.

1.4. Specifications

Motor requirements

- Motor type: bipolar stepper motor, DC motor.
- Rated winding current: minimum 100mA.
- Rated winding voltage: minimum 2V DC.

Electric specifications of the controller

- Power supply modes: external and USB.
- Current in each motor winding: up to 3A.
- Maximum encoder pulse frequency: 200 kHz.
- Stabilized 5V DC output (the power supply for encoder and other peripherals): 100mA maximum output current, 5% or better output voltage stability.
- ESD-protection on all pins of the output connectors (e.g., D-Sub 15 pin, mini-USB or power jack).
- Winding-to-ground short circuit protection.
- Winding-to-winding short circuit protection.
- Motor hot-swapping protection.
- Wrong power polarity protection (no more than 1s).
- Voltage overload protection (no more than 1s).
- USB-supplied current limitation.
- External power supply current limitation.
- Motor rotation speed limitation.
- Programmable full winding current with 10mA precision.
- Programmable winding current decrease with 1% precision for the hold mode.

Rotation control features

- Microstep modes: full-step, 1/2, 1/4, 1/8, 1/16, 1/32, 1/64, 1/128, 1/256.
- Noiseless at low speeds.
- Minimum speed is 1/256 of the full step per second.
- Maximum speed is up to 35 000 full steps per second for all microstep modes.
- Minimum shift is 1/256 of the step.
- Maximum shift is 2,147,483,647 full steps for all microstep modes.
- Smooth start/stop mode.
- 40-bit position counter (32 bits for full step and 8 bits for microstep).
- Motion modes: left/right move, move to point, shift on delta, continuous speed, acceleration and deceleration ramps, backlash compensation mode, automatic home position calibration mode.

Additional firmware features

- Automatic HOME calibration at firmware level.
- The nonvolatile memory used for saving/downloading the controller settings.
- Software update via USB interface.
- Automatic position saving according to step counter and encoder with power-off protection.

Additional features available via motor connector

- Processing the signals from one or two limit switches; software configurable.
- The Standa stages recognition and automatic downloading of the configuration file right from the stage if the last one supports this feature.
- The "step loss" detection and position recovery using either a revolution sensor or a quadrature encoder (if the stage supports this feature).
- The position detection using a quadrature encoder. The x4 mode.
- The stepper motor control using master quadrature encoder mode, providing the maximum speed without any step loss. Starting with firmware 4.1.

Additional features available via backplane connector

- USB connector on backplane that duplicates USB input on controller board.
- A serial RS-232 port. TX and RX lines are available. Specifications: 9600 - 921600 baud speed, TTL 3.3V. The Ethernet, Bluetooth, WiFi, ZigBee and other configurations based on the serial port are available by request.
- Synchronization input: once the pulse is received via this pin, the controller starts rotating the motor to predetermined position or by predetermined shift value. The triggering mode, the polarity and duration of the pulse are adjustable by user. Specifications: TTL 3.3V.
- Synchronization output: emit pulse to this pin if rotation is started or finished, or predetermined user-defined shift value is reached. The triggering mode, the polarity and duration of the pulse are adjustable by user. Specifications: TTL 3.3V.
- Left or right buttons. Once the button is pressed, the rotation in corresponding direction starts and the speed increases gradually according to acceleration and other settings. Specifications: TTL 3.3V.
- Joystick pin allowing operation with various joysticks with the voltage range no more than 0–3V.
- Magnetic brake control pin providing control to magnetic brake mounted on the motor shaft. Specifications: TTL 3.3V, 5mA.
- Common analog input pin allowing operation with signals within 0–3V range. Reading frequency is 1kHz. The configuration is programmable.
- Common digital input/output pin. 1kHz update frequency, software configurable. Specifications: TTL 3.3V, 5mA.

- Limit switches indication pins designed for LED direct connection. Specifications: TTL 3.3V, 2mA.
- Digital "Power" and "Status" pins duplicate the status LED and designed for direct connection of LEDs. Specifications: TTL 3.3V, 2mA.
- External driver control interface allowing to control any type of external driver using three signals: enable, direction, clock.
- Multiaxis systems development. The multiaxis systems are created from standard USB hubs, either external or mounted at a special backplane. On the PC a multiaxis system is represented as a set of virtual serial ports, according to the number of connected axes.

Programming the controller

- All the software supplied with controller is compatible with Windows 8, Windows 7, Windows Vista, Windows XP SP3, Linux, Mac OS X, including 64-bit versions.
- Controllers are supplied with cross-platform library and examples which allow rapid development using C++, C#, .NET, Delphi, Visual Basic, gcc, Xcode, Matlab, Java and LabVIEW.
- The XILab user interface is supplied with the controller. It allows to easily control all the functions and features of the device without any programming.
- A scripting language, an EcmaScript language dialect, is integrated into XILab software. It allows easy setting the sequence of actions, including cycles and branches, without compilation or learning any programming language.

1.5. Multi-axis system specifications

Power supply	external 220V, up to 10A
Power consumption	up to 1.5 kW
Power dissipation	up to 500 W
Supported motors	Stepper, DC
Number of axis	up to 36
Rated current	Up to 3 A with the total energy consumption of all controllers up to 1.5 kW
Protection types	current overload protection, voltage overload protection, short circuit protection, motor hotplug/unplug protection
Motion modes	move left/right, move to point, shift on delta, continuous speed, acceleration and deceleration ramps, backlash compensation mode, automatic home position calibration mode
Step modes	full-step, 1/2, 1/4, 1/8, 1/16, 1/32, 1/64, 1/128, 1/256
Rotation speed	up to 35 000 full steps per second
Speed profile	trapezoidal
Position counter	40 bit
Feedback	quadrature encoder (optional)
Closed loop control	supported
Limit switches	2
Revolution sensor	supported

2. Safety instructions

Power supply and grounding requirements. Connection to controller

General requirements for a [controller board](#), systems in box ([single](#) and [double](#) axes) and [multi-axis system](#) are listed below.

IMPORTANT. Either the power supply unit should be plugged to grounded 220V AC socket (a three-wire connection scheme). Make sure that the minus electrode of your power supply unit is grounded. If the power supply unit with minus electrode disconnected from the grounding circuit is used, ground the **controller board** via special **grounding terminal** (look at the picture below). Non-compliance with these rules may lead to the decrease in controller stability and noise resistance.

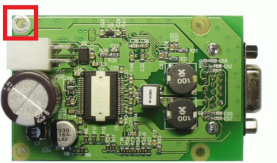

Top view of the controller board. A grounding terminal marked with the red square

Typical connection diagram for a controller (board, systems in box):

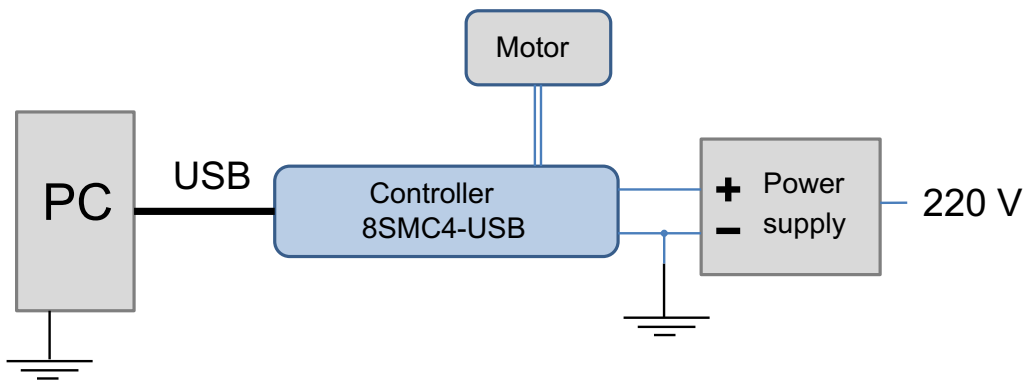

Controller grounded via minus electrode of power cable connection diagram

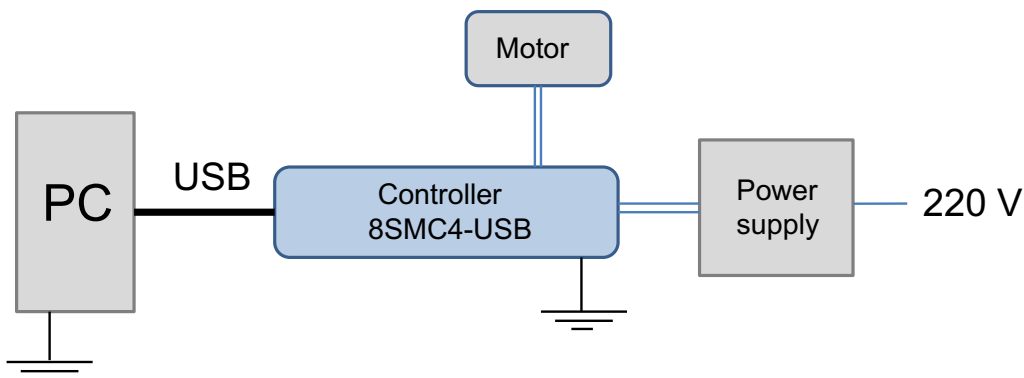

Controller connection diagram with grounding via special terminal

Warning. Power supply unit should be able to supply sufficient current to rotate the motor. As an absolute minimum it should be able to supply $I_{power.min} = \frac{2 * I_{motor} * U_{motor}}{U_{power}}$ where $I_{power.min}$ is the minimum working current of power supply unit, I_{motor} is the operating current in the winding, U_{power} is power supply unit stabilized voltage, and U_{motor} is rated operating voltage of the motor. It is recommended to use a power supply unit with operating current equal to $I_{power} \geq 2 * I_{power.min}$. The U_{power} voltage should be greater than U_{motor} . The higher the voltage, the faster rotation speed could be reached.

One can use power consumption of power supply unit to calculate minimum requirements instead. An absolute minimum of power is $W_{power.min} = I_{power.min} * U_{power} = 2 * I_{motor} * U_{motor}$. For example, for motor with operating winding current of 1A and operating voltage of 5V (with 5W rated power consumption), the operating voltage of power supply unit may be chosen at 20V with the output power of at least 10W (the maximum operating current of power supply unit is at least 0.5A).

Controller board

IMPORTANT. It is strictly forbidden to touch the [controller board](#) without any antistatic equipment. We recommend you to use antistatic wrist strap.

IMPORTANT. It is strictly forbidden to connect positive wire of power supply to the [controller board](#) when ground wire is not connected. It is strictly forbidden to connect or disconnect power cable when the power supply is on, the controller is connected to the PC and the power supply and the PC are grounded. This may damage the PC! This is a common requirement for any electronic device with separate power source, which is connected to the PC via USB.

Warning. Before connecting the [controller board](#) to the motor or to the PC via USB interface, it is recommended to connect controller to power supply with proper grounding or to use separate grounding for controller with the specially marked ground terminal (look [above](#)).

One and two axes system in box

IMPORTANT. You should not exceed maximum allowed voltage of 36V. If voltage goes over allowed value at more than 2 volts, it can immediately and irreversibly damage the controller.

Multi-axis system

The main feature of [multi-axis system](#) is 220V power connection, whereas power supply requirements listed above are not related to this system.

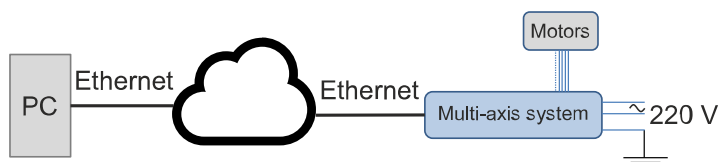

General multi-axis system connection diagram.

IMPORTANT. Multi-axis system should be plugged to grounded [220V AC socket](#) (three - wire connection). Non-compliance with this rule may lead to the decrease in system stability and noise resistance.

IMPORTANT. It is prohibited to touch inside the box while [module](#) is disconnected. There is 220V!

Note: Multi-axis system supports modules hot-plug and sudden disconnect of power supply 220V.

3. Overview and getting started

This guide describes the operation of controller for multi-axis and one-axis systems, basic parameters configuration and getting started with XiLab software for Windows 7.

- [One axis configuration](#) - a brief description of the beginning of work with the controller + 8SMC4-USB for one axis +. It is also considered quick XiLab setup and lists all necessary equipment.
- [Multi-axis configuration](#) - a brief description of the beginning of work with + multi-axis system based on the 8SMC4-USB controller +. It is also considered XiLab setup, lists all necessary equipment and describes characteristics of the system.
- [Example of a motor connection](#) - connection of stepper motor Nanotec ST5918L3008-B with encoder CUI INC AMT112S-V to 8SMC4-USB controller. It is described how to make your own cable, guided by the specification on the engine and explanation of the specification is given.
- [Manual profile setting](#) - setting of working profile for XiLab. Overview of the main features.
- [Calculation of the nominal current](#) - setting of amplitude of nominal current for stepper motors.
- [Possible problems and solutions](#) - description and solution of the most common problems when working with 8SMC4-USB controller.

3.1. One axis configuration

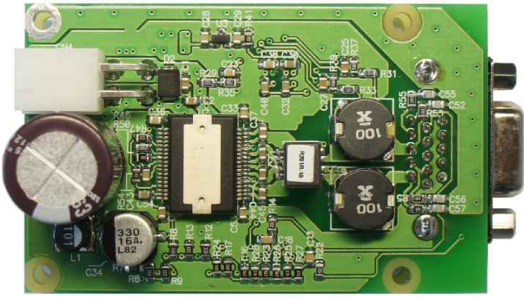

Controller board.

3.1. One axis configuration

Introduction
 System requirements
 Software installation and startup procedures
 Getting started with XILab software
 Functional test
 Control from user applications

Introduction

This manual describes the controller installation procedures and getting started with XILab software for Windows 7. The detailed controller specifications are described in [Specifications](#) chapter. For developing your own applications, please read the [Programming guide](#) chapter and download the programming software package from [the software](#) chapter.

System requirements

Note. There are only brief requirements in this chapter. For detailed information please read the [Specifications](#) chapter.

For successful installation you will need:

- **PC with USB port**



A standard PC with USB port.

Make sure that your PC has all of the current Windows updates installed. It will help you to maintain software compatibility. If necessary, please download the latest updates from www.microsoft.com/updates.

- **Software**
All necessary software to work with the controller can be downloaded from [software](#) page.
- **USB A - mini-B cable**



USB-A to mini-USB-B cable.

For detailed information about the USB cable please read the [data connector](#) chapter.

- **8SMC4-USB controller**

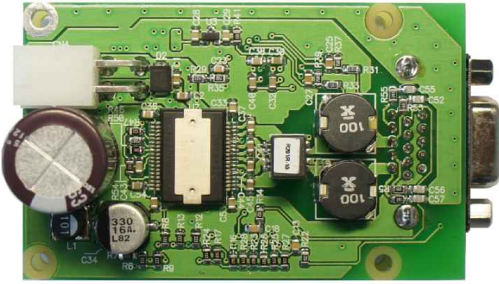

The motor controller board.

The controller appearance may differ from the one shown on the above figure depending on its configuration and version. For detailed information about versions please read the [Appearance and connectors](#) chapter.

- **Positioner or motor**



The stepper motor-based positioner.

The stepper motor-based positioner used in the operations is shown at the figure. The detailed motor requirements are described in [Specifications](#) chapter. If you use your own cables for connecting the positioner to the controller, please refer to [positioner connection scheme](#) and [the controller's output connector scheme](#). For positioners with limited movement range, two [limit switches](#) must be used: SW1 and SW2. These pins are used to determine the movement limits.

- **Power supply**



Stabilized power supply unit.

Notes.

- Please use the 12–36V DC stabilized power supply. Too high voltage may damage the controller. For more information please read the [Safety instructions](#) chapter. The power supply unit must provide the current enough for sustainable rotation of the motor.
- Please pay attention on the manual supplied with your controller. The more strict power voltage limitation is possible depending on the controller model. Please check the connection of external power supply unit to the controller carefully.
- If controller is supplied inside the metal case, the case must be grounded. If controller is supplied without any body, the grounding circuit of power supply unit is used. For more information please read the [Safety instructions](#) chapter.
- If the board is operated without the casing, make sure it lays on the insulating surface and there are no extraneous particles on the board or around it.

Software installation and startup procedures

Make sure that all controllers are disconnected from your PC.

The software installation manual is [here](#). The installer file name is "xilab-<version_name>.exe". It automatically detects whether it is running on 32-bit or 64-bit version of Windows and installs the appropriate version of XiLab. Launch the installation program, the installation window will appear. (The software versions may slightly differ from each other).



XiLab main installation window.

Press "Next>" button and follow the instructions on screen. All the necessary software including all drivers, packages and programs will be installed automatically. After installation is finished, the XiLab software starts by default and the following window will open:



XiLab "No devices found" dialogue window.

Don't press any buttons.

Connect the positioner to the controller. Connect the stabilized power supply unit to the controller. Ground the controller or power supply unit. Connect the controller to your PC using the USB-A to mini-USB-B cable.

The LED indicator at the controller board will start **flashing**. The New Hardware Wizard starts working after the first connection of the controller to PC. Please wait until Windows detects a new device and installs all necessary drivers for it.

If the automatic driver installation has failed, please select "No, not this time" in the window being opened and press "Next>" button. Select "Install from a list or specific location (Advanced)" in the next window and press "Next>" again. Browse the software disk supplied with controller and find the *.inf file there or in the XiLab-install-path\driver\ folder and wait until installation is completed.

Go back to XiLab "No devices found" dialog window and press "Retry" button.

If this window was closed, please go to "Start" menu, select Programs->XiLab X.X.X->XiLab and launch it. The dialog window will open again.

Getting started with XiLab software

XiLab is a user-friendly graphic interface designed for control, diagnostics and adjustment of motors. It can also be used for easy installation and save/restore of parameters for any type of motors. This chapter describes the startup procedures with XiLab software. For complete information please refer to [XiLab application User's guide](#) chapter.

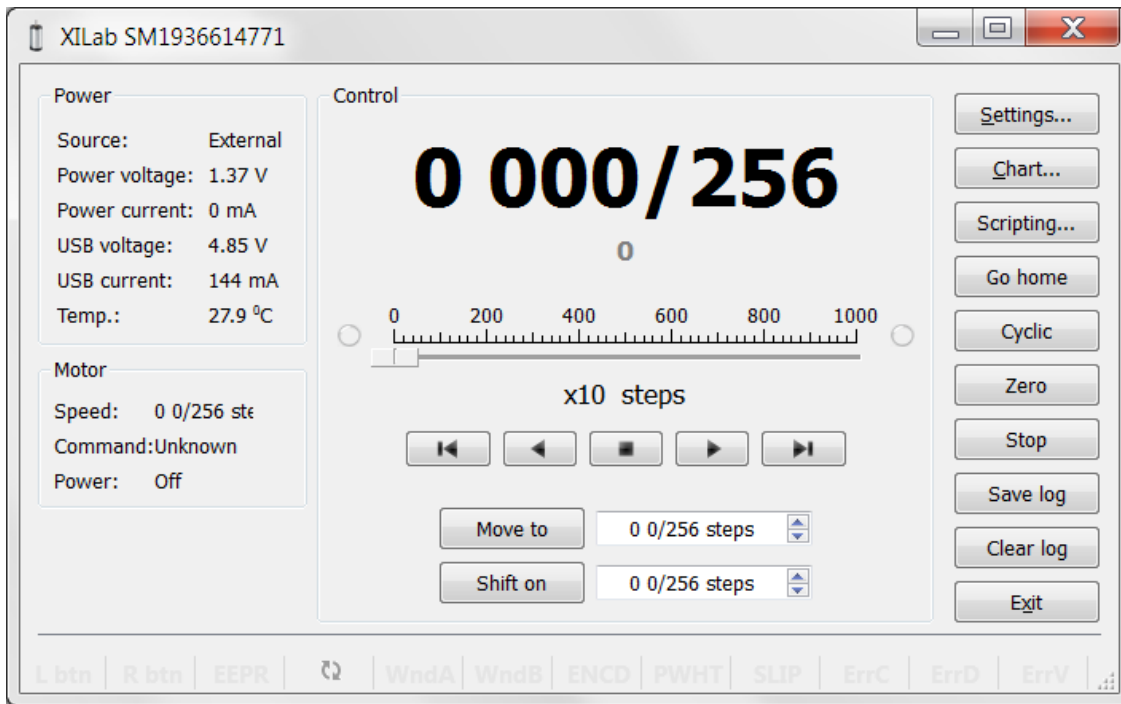

XILab main window.

Open "Settings...", then press "Restore from file..." and select the configuration file for your positioner from the opened C:\Program Files\XILab\profiles\ folder. The values applicable for your positioner will automatically fill all the fields of "Settings..." menu. If the necessary file isn't found, please refer to the [Configuration files](#) chapter. If there is still no solution, please leave your request at our customer service website.

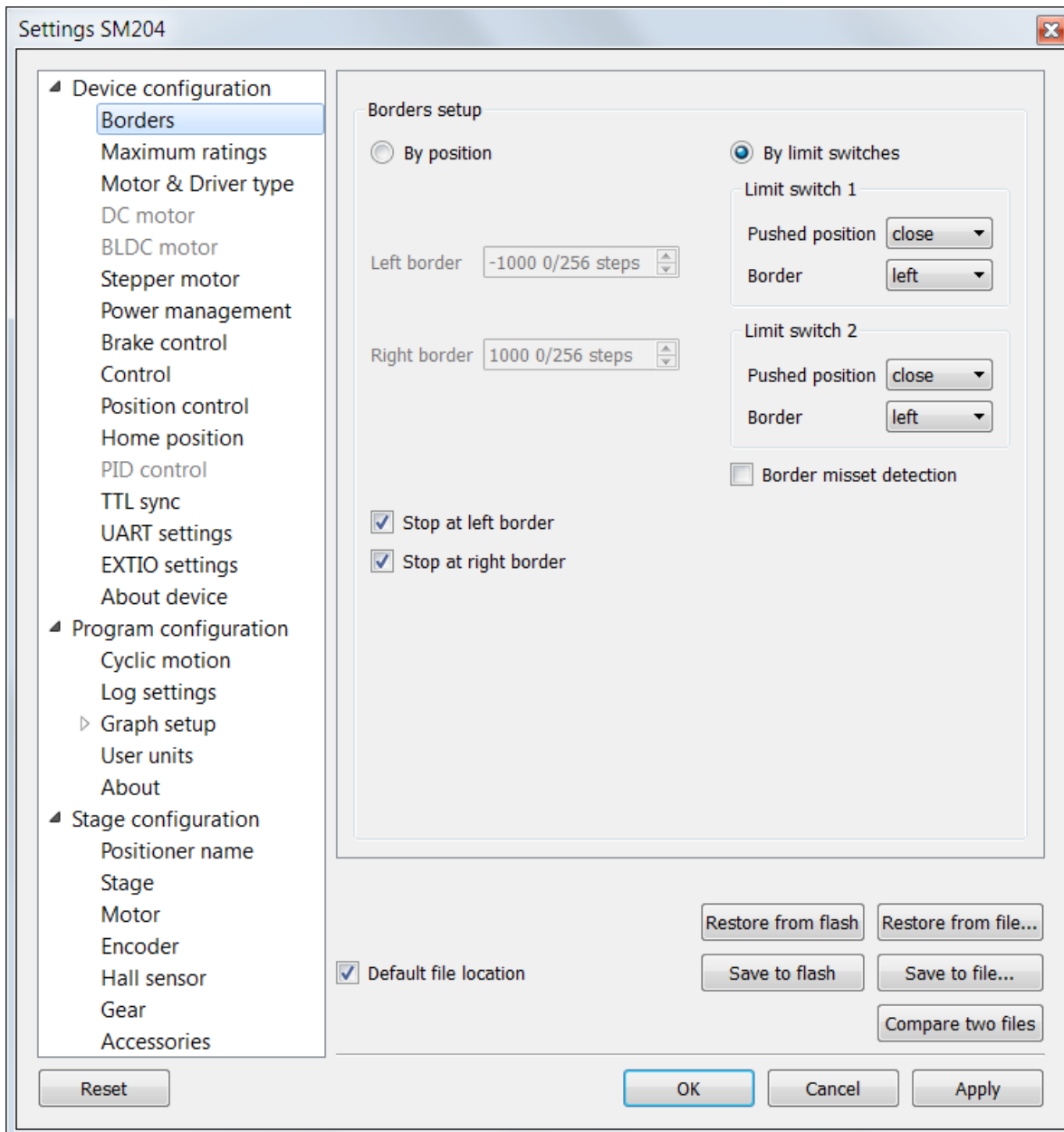

XILab, the Settings menu window.



Warning. For the controller to work with stepper motors it is required to properly set up:

- [working current](#),
- [displacement limits and limit switches](#),
- [critical parameters](#),
- [limiters](#),
- [power supply mode](#).

If you decide to configure your controller by yourself, please check these parameters carefully!

Congratulations, your controller is ready for operation!

Functional test

Check if the controller is configured properly by pressing left or right button in the central row of XILab main window control buttons. The positioner has to start moving. Use the central "soft stop" button to stop the rotation. Please pay attention to the power supply parameters of the controller in the *Power* section. The power voltage, working current and temperature of the controller can be set there.

If Xilab main window is shaded red when the movement was supposed to start, that means that protection was activated and controller entered the *Alarm* state. This may be caused by incorrect settings, wrong connection of the positioner or controller malfunction. For detailed information please read the [Critical parameters](#) chapter.

Control from user applications

Xilab software is a convenient way to control stages connected to 8SMC4-USB controller. However, if you need to control the 8SMC4-USB from your own application, you may do so by using libximc library. [Programming guide](#) has several examples in C, C#, Delphi, Java, VB.net, [Matlab](#), [LabView](#) programming languages. If all you need is to automate a small number of control steps, then instead of a standalone program you may find it easier to use Xilab [scripting language](#).

3.2. Multiaxis system

3.2. Multiaxis system
 Introduction
 Required components
 Getting started with multi-axis XiLab.
 Multi-axis system temperature control.



Appearance of the multi-axis system

Introduction

This manual describes start with multi-axis system (8SMC4-B36) based on 8SMC4-USB motor controller. 8SMC4-USB getting started described in [overview and getting started](#) chapter. Multi-axis system operates from 220 V and it allows to control 36 axis simultaneously.

Required components



220 V power cable



Ethernet cable. It allows you to control multi-axis system remotely

DHCP server is needed for control of multi-axis system via local network. You should know ip address of your devices in network.

Getting started with multi-axis XiLab.

Connect 220V and Ethernet cable to multi-axis system. Press Power On/Off button at the back panel. After 2 minutes 8SMC4-B36 is ready to use. It needs time to start operating system on board computer for multi-axis system control.

At start you need XiLab with multi-axis support version... or newer. Link to download. Setup process and getting started with XiLab described [here](#). For complete information please refer to [XiLab application User's guide](#) chapter.

At first start, XiLab opens controller detection window with no devices found.

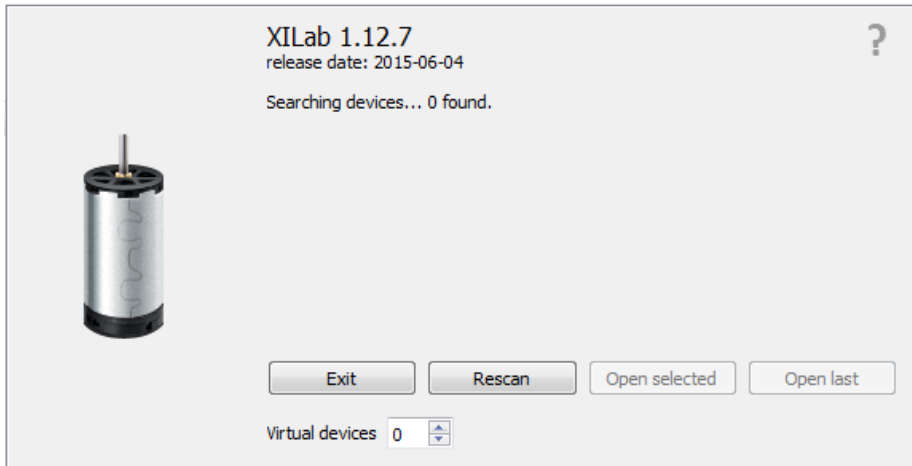

Add virtual XIMC controller by increasing the number of Virtual Devices in the bottom part of window and click Rescan. Then choose Virtual XIMC, SN1 and click Open selected.

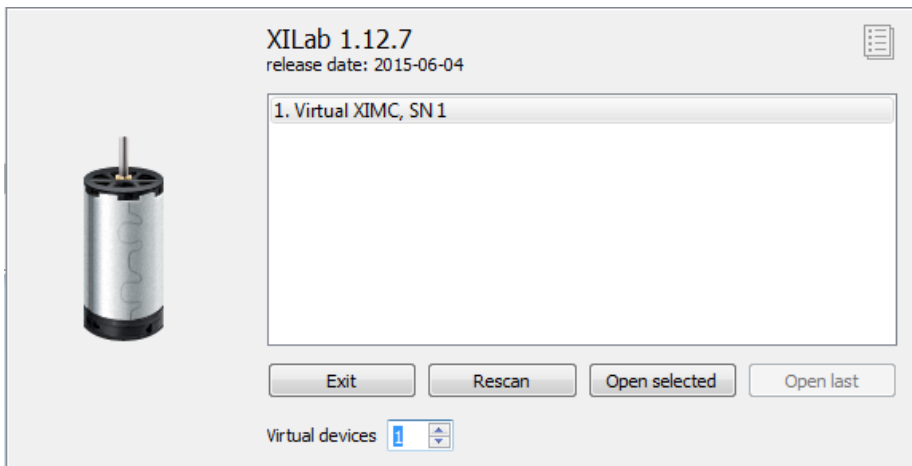

XiLab main window with single axis mode will appear. Go to Settings... and choose Program configuration (for detailed information please refer to [XiLab general settings](#)). Check Enumerate network devices in Device detection settings and press "Scan for local XIMC servers" button. XiLab will use broadcast request to find available server in multi-axis system, if the server was found its IP will appear in the "IP/hosts" list. You can also edit address list manually if desired. Click OK and close XiLab.

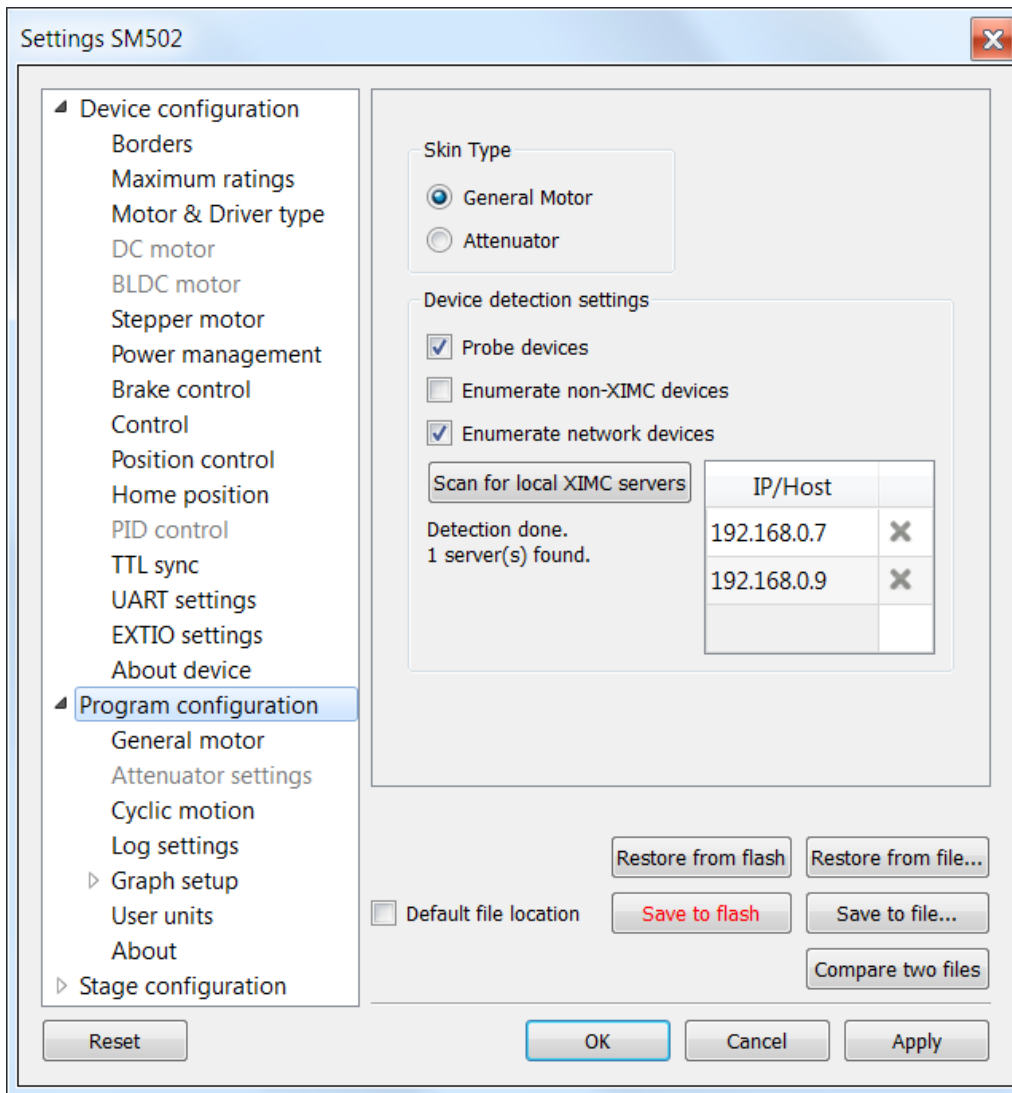

When you restart XiLab it will find all axis connected to the system. In controller detection window choose an axis you need. You can control it in [single-axis mode](#) or in [multi-axis mode](#) if more than one axis was chosen. For additional information please refer to [Getting started with XiLab software](#) and [XiLab application User's guide](#)

Multi-axis system temperature control.

Multi-axis system 8SMC4-B36 is able to control heating of its controller's during operation. It can measure temperature of circulating air via thermal resistors. With temperature increase speed of cooling system fans rotating will increase too.

At temperature of circulating air about 25°C cooling system is at 10% of its maximal power. 100% of power is achieved with temperature about 45°C.

3.2.1. Errata

All of the following notes are for a multi-axis system version 1.1.

Operation

Main problems related to multi-axis system operation.

- When powered from 110V full power is limited to 1 kW.
- While simultaneous emergency stop of several axes occurs at high power motors, there can be short-term connection loss with a multi-axis system control interface.
- There is possible a failure with consequent axes rediscovery in OS due to modules hot plug.
- When updating the firmware, controllers can lose USB connection, and are not available in XiLab, until the system is restarted.
- It is possible that when inserting the module in the operating system, it is not energized and fails to work.

Construction

Structural defects of the multi-axis system that may be encountered during disassembly and assembly.

- ic9xbb board. Silkscreen P1 - P5 must be on the other side of the corresponding connectors.
- ic9xbb board. Mixed up silkscreen of P1 and P3 connectors.

3.3. Example of a motor connection

3.3. Example of a motor connection
 General case
 Positioner standard connection diagrams
 Example
 Preparation
 Connecting the motor and encoder to the controller

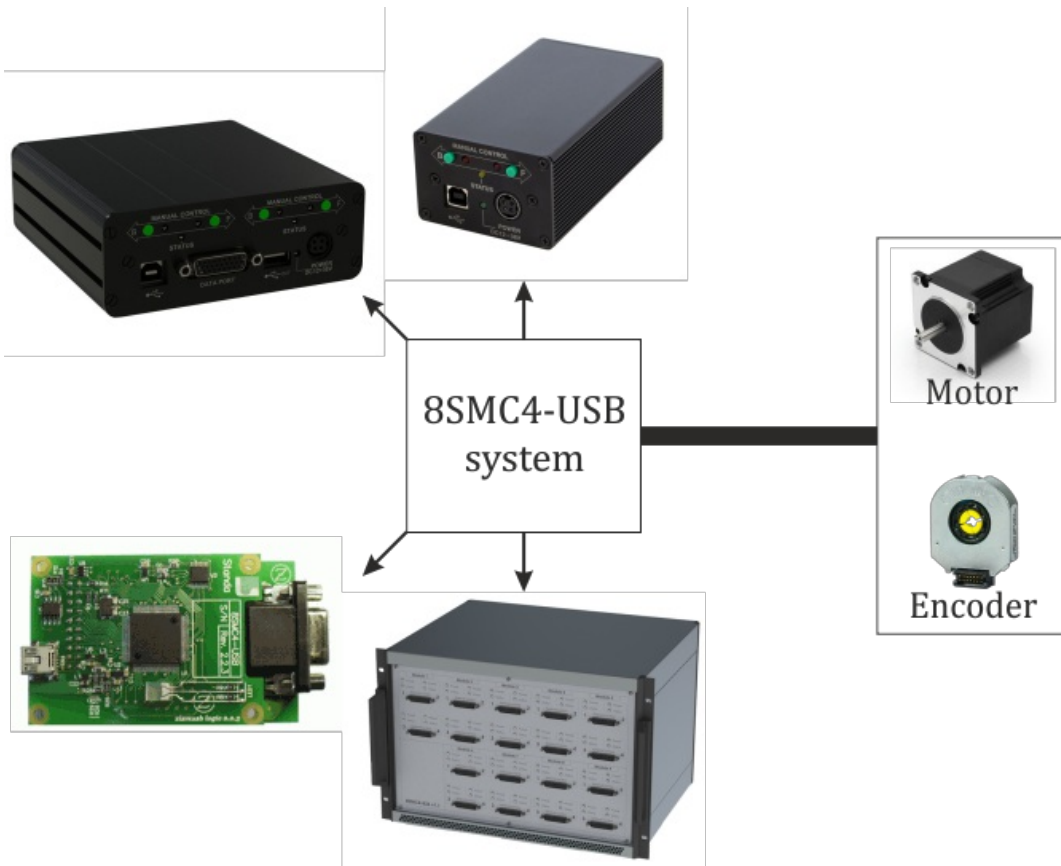

General case

To connect a motor to the controller please refer to [positioner connector](#), and use the scheme of positioner connection:

Positioner standard connection diagrams

DSub connector

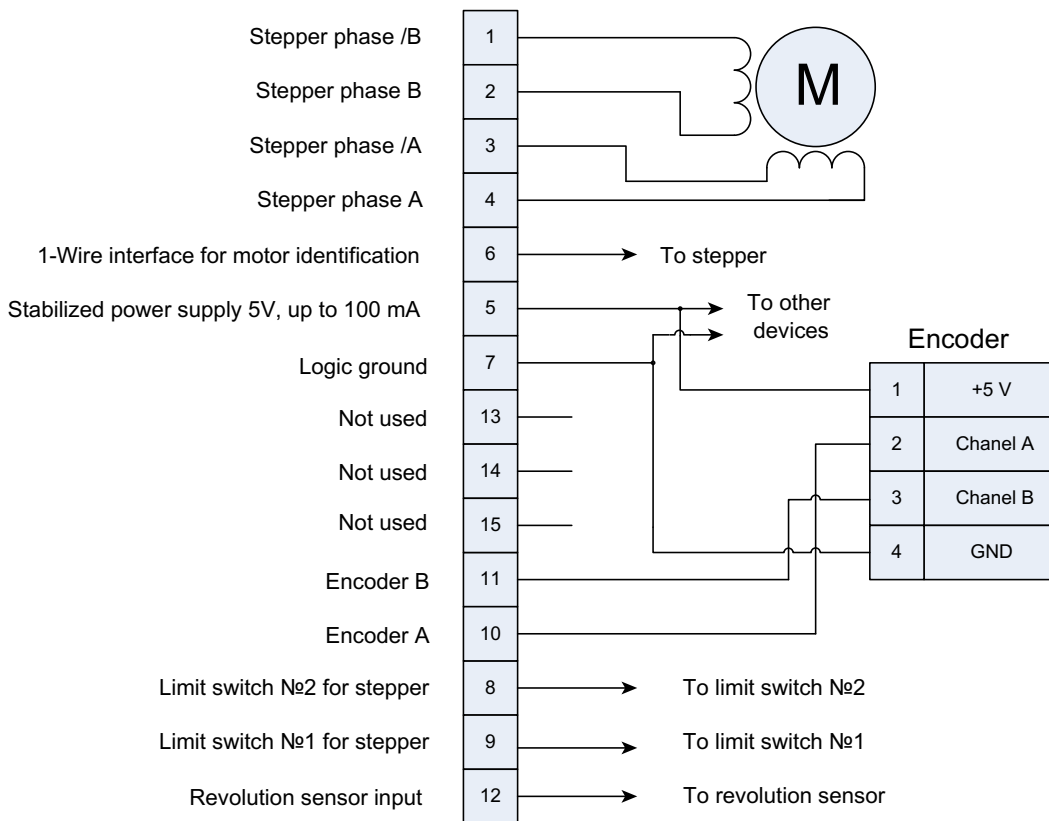

General diagram of positioner and encoder connection using Dsub connector.

Note. If A and B encoder channels work in open drain mode, some extra pull-up of encoder outputs to 5V power voltage using the resistors may be required at high rotation speeds in order to provide the maximum signal transmission speed (see [Operation with encoders](#)).

Example

Consider the connection of the two-phase stepper motor Nanotec ST5918L3008-B with encoder CUI INC AMT112S-V to controller 8SMC4-USB.

Preparation

To get started, we need:

- Motor;
- Encoder;
- [Pinout of D-SUB connector](#) for 8SMC4-USB;
- [Motor datasheet](#) ;
- [Encoder datasheet](#) ;
- Soldering equipment: soldering-iron, wires, flux, solder, nippers, heat shrink tubes of different sizes;
- Screws M2.5x6 for fixing the encoder;
- D-SUB cover + connector (male) and wires for cable manufacturing;





Connecting the motor and encoder to the controller

- Before you begin, assemble the encoder in accordance with the appropriate instructions.

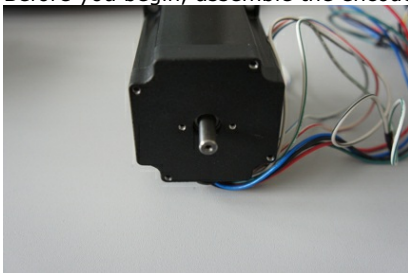

The motor without encoder. Note 2 holes M2.5 to which is usually attached an encoder



Motor with attached encoder

- Let us look in the specification of the engine and find the wiring diagram (for Nanotec ST5918L3008-B it is at the bottom right in the specification):

WIRING DIAGRAM

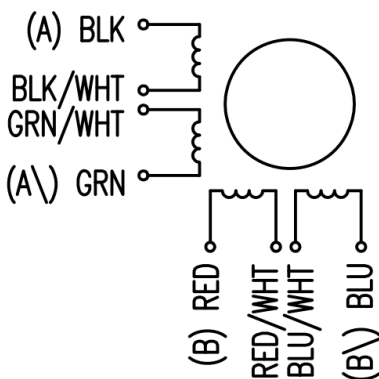

Motor contacts

TYPE OF CONNECTION (EXTERN)				MOTOR		
UNIPOLAR	BIPOLAR			CONNECTOR PIN NO. (A)	LEADS	WINDING
	1WINDING	SERIAL	PARALLEL			
A	A	A	A	1	BLK	A
COM				3	BLK/WHT	
A\	A	A\	A\	2	GRN/WHT	A\
B	B	B	B	4	GRN	B
COM				5	RED	
A\	A\	A\	A\	7	RED/WHT	A\
B	B	B	B	6	BLU/WHT	B
COM				8	BLU	

Connection type

- There exist serial and parallel winding connection and each type allows to obtain various characteristics for the motor. We will connect the windings in series (red frame on the picture). To do this, wires having two colors BLK/WHT and GRN/WHT, as well as RED/WHT and BLU/WHT must be connected to each other in pairs. Next, you need to put in accordance A, not A, B, not B pins of controller to contacts of motor windings ST5918L3008-B: black, green, red, blue. One winding is a connection of A and not A or B and not B. After the connection between a two-color wire, you will get that one winding of the motor is black - green connection, other is red - blue. Therefore, matching contacts will be the follows: black - A, green - not A, red - B, blue - not B. It can be seen in the picture above *Connection type*.

- To connect encoder, open its datasheet and find 5 contacts on encoder connector: A+ (channel A), B+ (channel B, shifted relative to A by 90 degrees), Z+ (rev counter), 5V, GND. They should be taken from the encoder as 5 separate wires and put together with the wires from the motor as they then go to a connector. CUI INC AMT112S-V encoder has 18 pin input, therefore it is needed to make a cable with the same connector on the end to output necessary signals:

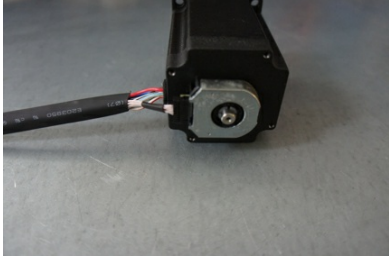

Encoder contacts A+, B+, Z+, 5V and GND corresponds to 10, 11, 12, 5, 7 pins of [D-SUB male connector](#) respectively.

For convenience, use the next tables (the number in parentheses indicates pin on the corresponding connector):

Encoder pin	D-SUB pin
A+ (10)	Encoder A(10)
B+ (8)	Encoder B(11)
Z+ (12)	Revolution sensor input (12)
5V (6)	Output 5V, 100 mA (5)
GND (4)	Logical ground (7)

Motor pin	D-SUB pin
A (BLK)	phase A (4)
not A (GRN)	phase not A (3)
B (RED)	phase B (2)
not B (BLU)	phase not B (1)

- Solder the above contacts to D-SUB male connector:

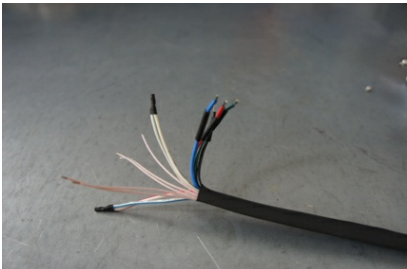

The wires from the motor and encoder in a heat shrink tube. Note the presence of small heat-shrinkable tubes for wires going to the motor windings (BLK, GRN, RED and BLU), as well as two-colored wires joined together (BLK/WHT and GRN/WHT, RED/WHT and BLU/WHT). The thin wires are an encoder contacts (5 pcs).

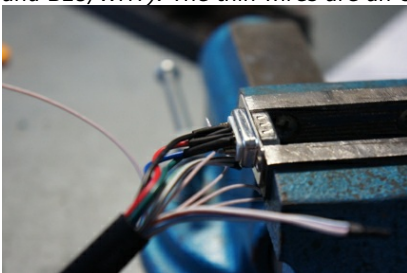

Soldered contacts of the motor windings

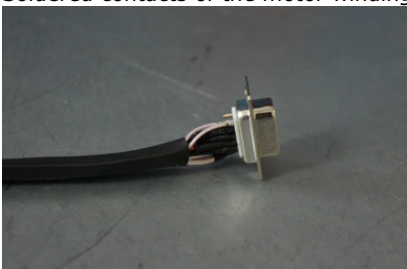

Ready cable from the motor with the D-SUB connector on its end

Recommendation: use heat shrink tubes of a small diameter (2-3 mm) while soldering contacts to D-SUB connector, and large

diameter to skip through them all the wires coming from the motor and encoder. Put them before soldering.

- Put D-SUB connector into the cover.

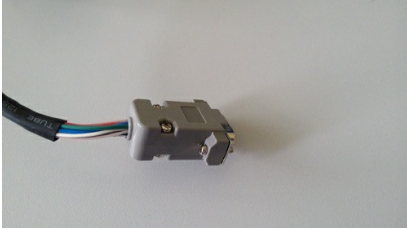

- Now you can connect it to 8SMC4-USB.

Description and profile settings are given in the next chapter [Manual profile setting](#).

3.3. Manual profile setting

Introduction

All necessary parameters are set after motor connection (see [Example of a motor connection](#) where the Nanotec ST5918L3008-B motor connection is described). There we will consider the setting of the profile for **Nanotec ST5918L3008-B** stepper motor.

Getting started

- Install and run XiLab (see [One axis configuration](#)).
- Load the profile with default settings. To do this, open + Settings -> Restore from file ... + and select xilabdefault.cfg file from XiLab folder.

Nominal current setting

Initially, it is needed to set a correct current in motor windings:

- From the [specification](#) find the **phase current 2.1 A** - this is the maximum current for the motor in case of **serial** winding connection:

SPECIFICATION	CONNECTION	UNIPOLAR OR BIPOLAR		
		BIPOLAR-1 WINDING	SERIAL	PARALLEL
VOLTAGE (VDC)		3.0		
AMPS/PHASE		3.0	2.1	4.2
RESISTANCE/PHASE (Ohms)@25°C		1.0±10%	2.0±10%	0.5±10%
INDUCTANCE/PHASE (mH) @1KHz		2.2±20%	8.8±20%	2.2±20%

- Being in the [Settings](#) window, open [Stepper motor](#) tab. There are such parameters as rotational speed, acceleration, driving mode, etc. (see [Settings of kinematics \(stepper motor\)](#) for additional information). In [Motor parameters-> Nominal current](#) field you should specify the value of the phase current **not exceeding 2.1 A**:

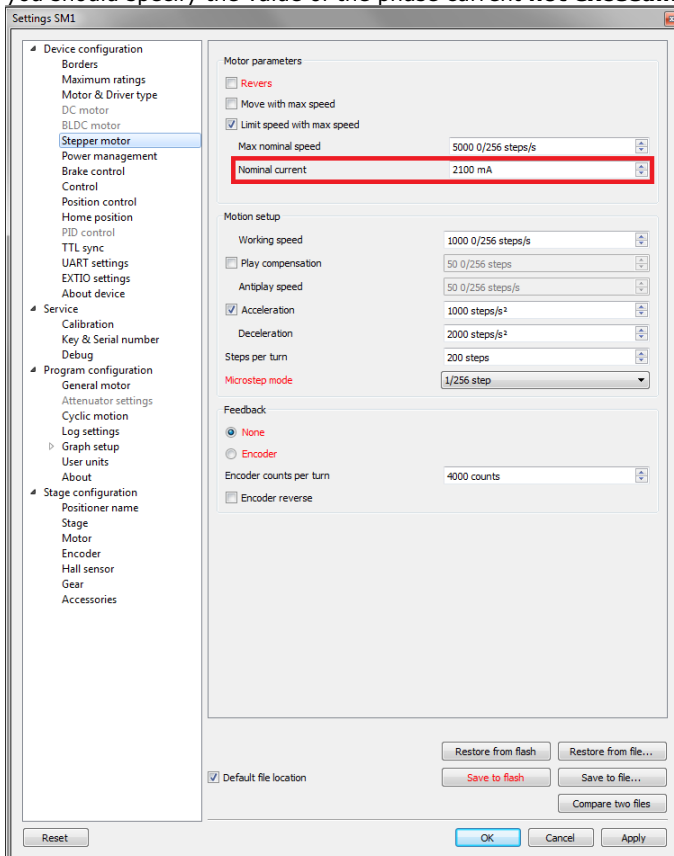

Basic parameters setting

- In the [Working speed](#) field we will specify a rotation speed. The recommended speed is not more than **1000 s/sec** at the first start. In the same window you should type **Max Nominal Speed (5000 s/sec)** is reasonable value for majority of motors and motorized stages) and mark [Limit speed with max speed](#). This setting is necessary to limit the motor speed since some mechanical systems can be designed for low speed, and fast rotation can lead to severe wear of motor/stage mechanics.
- In the motor specification we find the number of steps per rotation. For our motor this value is equal to **200 steps**. Specify it in the [Steps per turn](#) field. Usually, the value of one pitch in degrees is listed in motor description, on the basis of which you can

3.3. Manual profile setting

- Introduction
- Getting started
- Nominal current setting
- Basic parameters setting
- Hardware limit switches setting. Homing.
- Encoder parameters setting
- Setting the kinematic characteristics of the controller
- Working with user units

calculate the number of steps per revolution, knowing that one revolution consists of 360 degrees.

- Make sure that movement to the right from the main window of XiLab corresponds to the movement to the right of the stage. If not, then check the box Reverse field Stepper motor -> Motor parameters.

Hardware limit switches setting. Homing.

Note. This section describes the using of motorized stages with hardware limit switches. If your system is not provided with hardware limit switches, it is recommended to disable stop by limit switches in settings. To do this, unmark Stop at right border and Stop at left border in Borders tab.

There are positioners with limited (translators) and an unlimited range of motion (rotators). The limitation of movement range can be done by position or with limit switches using. When you work with translators if its limit switches are configured incorrectly there exists a risk to break down mechanics, since moving part can try to go out of motion range. Rotators do not have such problem. Moreover, it should be kept in mind that rotator may have only one limit switch.

- To work with limit switches you must specify which one will be left and right. Sometimes it is unknown in advance and we only know that both switches are connected and fire if the corresponding limit of the motion range is reached. The stage jam is possible if the limit switches are configured improperly. Therefore, the controller supports just a simple detection of incorrectly configured limit switches, shutting down the movement on both of them. Please make sure that:
 - The stage is far from limit switches;
 - Switches polarity is configured correctly (limit switches indicators are off in the main window of XiLab). In the case of incorrect settings, change their polarity (Borders -> Pushed position), indicators should go out.

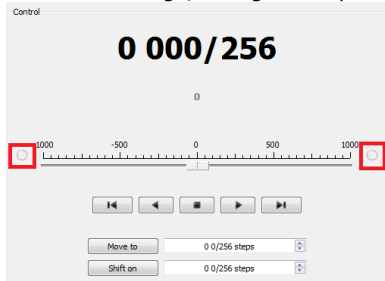

- Shutdown mode is activated on both of limit switches (Stop at right border and Stop at left border are marked in Borders tab).

- Mark the flag detecting improper connection of limit switches Border miset detection in Borders tab.

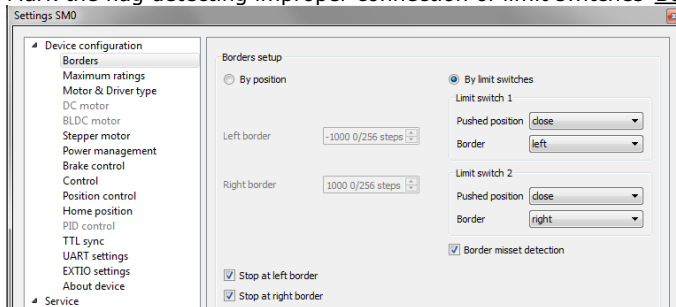

Tab with limit switches settings

- Controller can switch to Alarm state after false limit switch response, if Enter Alarm state when edge miset is detected is enabled in Maximum ratings tab. It is recommended to enable it. Start the movement in any direction from the main window of XiLab up to Alarm state or stopping by the limit switch. When an Alarm occurs you need to reverse limit switches by changing Borders->Border with reversed values in the Stepper motor tab.



Warning. The protection against mistaken limit switches connection doesn't guarantee the complete solution of the problem, it only makes the initial configuration procedure easier. Don't start the movement with mixed up limit switches if any of them is active, even if the protection is on.

There are still two ways to determine which of the limit switch is right and which is the left:

- You need to know how each of the limit switches is connected to the positioner. When loading a profile with the default settings, switch connected to pin 9 of the D-SUB connector is considered as left, while switch connected to pin 8 - as right. Their location relative to the positioner is configured in the fields Limit switch 1 and Limit switch 2 (see screenshot above). Start the system at the low speed (<100 μ /c) when it is far away from limit switches. If the direction of movement to the switch in a real setting differs from the expected, change Borders->Border values with reversed in the Stepper motor tab.

- If it is possible to get limit switches activate them and note the correspondence between indicators in XiLab and each particular switch. Then start the system at the low speed (<100 μ /c) when it is far away from limit switches and make sure that the system moves to the right switch. Compare this to what you see in the main window of XiLab. If the direction of movement to the switch in a real setting and in the main window differs, change Borders->Border values with reversed in the Stepper motor tab.

For detailed information refer to [motion range and limit switches](#).

- Controller has a useful function called [automatic Home position calibration](#) to set the initial position of the motorized stage.

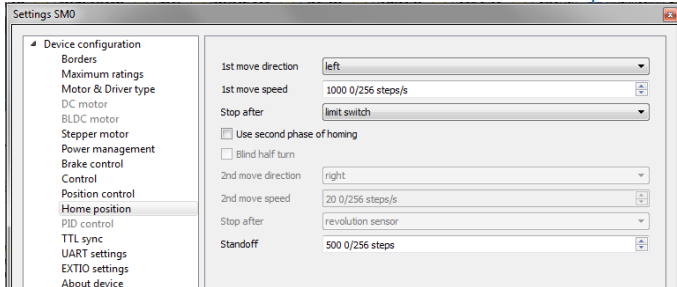

We will consider the most simple configurations with a single phase only. Start from the setting of the 1st phase speed which is approximately 5-10 times lower than Working speed. It is necessary for higher precision of automatic calibration procedure. In the filed Stop after specify the limit switch to make the stage reached one of the limit switches during the calibration (direction is selected in the 1st move direction). In the field Standoff specify number in steps, for which stage must be driven away from the limit switch. Click Ok or Apply.

Note. Standoff value is signed. Positive direction is right. That is, if the auto-calibration procedure is set up on the right limit switch, then in order to move stage away to the left you should type negative value in Standoff field.

- Start the automatic calibration by clicking Go home in the main window of XiLab. The result of it is a movement of the positioner to the specified limit switch with a relatively low speed and the shift away from him to the value specified in the field Standoff.
- After completion of the calibration process, press Zero in XiLab to set the origin of coordinate system for your stage.
- Repeat the calibration process again. The stage must return to the zero position. Please pay attention that there can be slight deviations from zero connected with calibration procedure error.

Encoder parameters setting

Note. This section describes the using of motor with encoder. If you motor without an encoder, the parameters described below can be left unchanged.

- Any encoder has **Pulse Per Turn - PPT** parameter (sometimes it is called **PPR - Pulse Per Rotation**). For correct operation of the encoder with controller you should enter the number of encoder counts per revolution, which is equal to **4xPPT** in the Encoder counts per turn field in XiLab. For example, if your encoder has **1024** pulses per turn, specify **4096** in the Counts per turn:

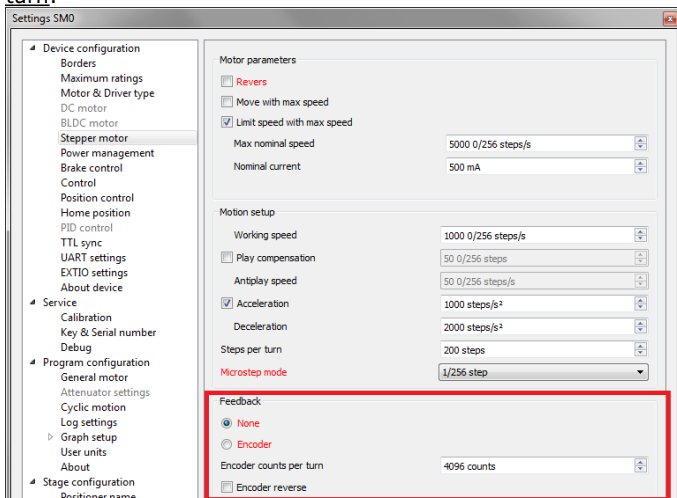

- Start the motor rotation from the [main window of XiLab](#). If everything is configured correctly, the green indicator **ENCD** will light in the bottom of window. If **ENCD** has yellow color, you should mark Encoder reverse in the Stepper motor tab. Red color of **EDCN** points to the problem with [encoder position recalculation](#)..

- It is possible to activate the position control by encoder. To do this, in the tab [Position control](#) mark [Position control](#) and specify allowable error in terms of encoder counts in the [Threshold](#) field. Then, when a mismatch between position and encoder counts occurs, indicator **SLIP** will light in the bottom of XiLab main window. Beyond this, if [Alarm on errors](#) is marked, the controller will go to Alarm state. [Correct errors](#) allows you to start closed loop control, when the difference between real position and encoder position is compensated.

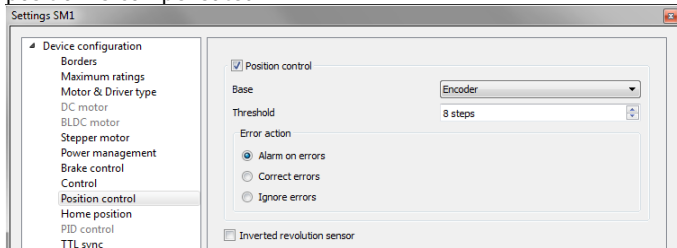

Setting the kinematic characteristics of the controller

- In the [Stepper motor](#) tab you may specify a necessary acceleration ([Acceleration](#)) and deceleration ([Deceleration](#)) for your stepper motor. The process of optimal values selection is the next:
 - Starting from default values make small shifts (start and fast stop) with gradual [Acceleration](#) increase until the movement become unstable and disrupted sometimes. Take acceleration equal to about **half** of this value.
 - The deceleration can be configured about **1.5 - 2 times higher** than acceleration.
- If in your mechanical system moving to the desired position on the left and on the right is not the same, and there is play, it is possible to eliminate this ambiguity. To do this mark [Play compensation](#) in [Stepper motor](#) and type number greater than play value. The sign of this setting determines the direction of moving to the position. Positive sign means move from the left while negative - from the right. In [Antiplay speed](#) field set the speed of compensation movement. This value should be low (**50 s/sec** is enough) in order to avoid "drifting" during play compensation.
- After the basic configuration of the positioner/motor, you can increase working speed. It can be done experimentally like the process of acceleration setting, i.e. you should take its value **about 2 times lower** than value at which there is unstable movement. To test the stability of the rotation it is recommended to use the function [Cyclic](#) in XiLab [main window](#). Make sure that you [set](#) it previously.

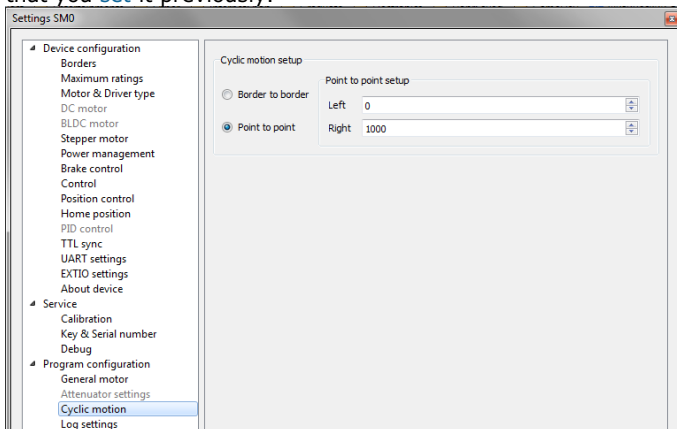

- In the [Microstep mode](#) field we recommend to enter the value **1/256**.

Working with user units

Often it is uncomfortable to work with the steps and microsteps and more convenient units are preferable. For this reason, the controller can recalculate the coordinates in the usual units, for example in millimeters or degrees. It can be done in the tab [User units](#), where you should specify the size of the step and the corresponding measurement unit. For more information, refer to [relevant documentation paragraph](#).

Configuration of the operating profile complete.

3.4. Calculation of the nominal current

In order to stepper engine gave maximum torque, but it does not overheat, it is important to specify such technical characteristic as the rated current.

The greater a current in the motor winding, the greater the torque at the axis. It is important to remember that with an increase a current flowing through the winding, thermal power released by the motor increases. So the engine could operate for a long time allocated to thermal power (Joule heating) must be less power dissipation. Power dissipation can be calculated on the basis of documentation on the engine.

Calculation based on the parameters of unipolar full step mode

Power dissipation is equal to $P = n \cdot R_u I_u^2$, where R_u - the resistance of the winding in unipolar mode, I_u - current through the winding in unipolar mode, n - the number of simultaneous windings.

Consider, for example, [ST2818M1006](#). The table in the documentation shows that in full step mode simultaneously running two phase ($n = 2$) in the unipolar mode, i.e. $P = 2R_u I_u^2$. The motor controllers support only bipolar control mode. To switch from a unipolar to a bipolar mode, connect each phase windings in series, the resistance will increase, $R_b = 2R_u$, where R_b - the resistance of the series-connected windings in the bipolar control mode.

The motor controllers control algorithm is capable of operating in a microstepping mode and maintains the current so that the first winding current varies in function $I_a \sin(\phi)$, in the other winding current varies in function $I_a \cos(\phi)$, where I_a - current amplitude. Thermal power released two windings at any time $P = R_b I_a^2 \sin^2(\phi) + R_b I_a^2 \cos^2(\phi) = R_b I_a^2$

It follows from the foregoing that the $I_a = I_u$

Calculation based on the parameters of bipolar full step mode

Power dissipation is equal to $P = n \cdot R_b I_b^2$, where R_b - the resistance of the winding in bipolar mode, I_b - current through the winding in bipolar mode, n - the number of simultaneous windings.

Consider, for example, [ST2018S0604](#). The table in the documentation shows that in full step mode simultaneously running two phase ($n = 2$) in the bipolar mode, i.e. $P = 2R_b I_b^2$

Thermal power dissipated in the motor windings that managed by motor controller, still is $P = R_b I_a^2 \sin^2(\phi) + R_b I_a^2 \cos^2(\phi) = R_b I_a^2$

We obtain the equation equating power $2R_b I_b^2 = R_b I_a^2$. We find that $I_a = \sqrt{2} \cdot I_b$

The relationship with an rms current

Alternating current in each motor winding can be characterized by its rms value in the period

$$I_{rms} = \sqrt{\frac{1}{2\pi} \int_0^{2\pi} (I_a \sin(\phi))^2 d\phi} = \frac{I_a}{\sqrt{2}}. \text{ Thermal power of one winding is associated with an rms current through it } P_1 = R_b I_{rms}^2.$$

Both windings are identical $P_1 = P_2$. The total thermal power of the engine that is run by control by motor controller controller $P = P_1 + P_2 = 2R_b I_{rms}^2$

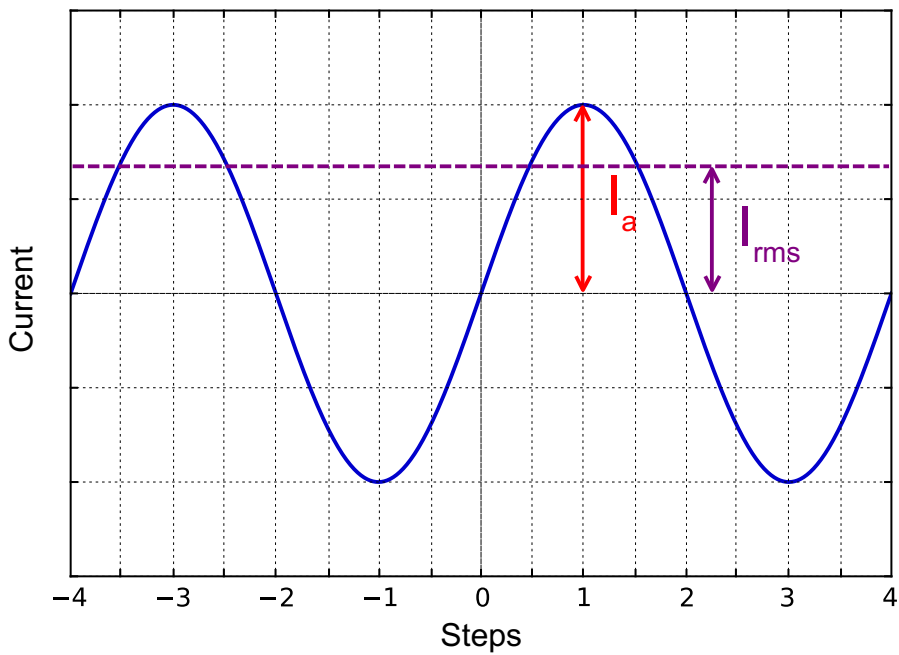

It follows from the foregoing that $I_{rms} = \frac{I_u}{\sqrt{2}}$, also $I_{rms} = I_b$

Setting the nominal current

Motor controller are capable of taking the nominal current value as a current amplitude or as rms. The choice of which way to interpret the input value of the nominal current is determined by the absence or presence corresponding flag `ENGINE_CURRENT_AS_RMS` in the `EngineFlags engine_settings` structure. When [setting the nominal current in XILab](#) should properly specify how the current is interpreted. Motor controllers in this case will provide the maximum torque without overheating the engine.

For all Standa motorized positioners prepared configuration files that contain the specified nominal current as rms. The corresponding flag is set. Thus the engines operate at optimum settings.

3.6. Possible problems and solutions

Here is a list of common problems and possible solutions that we offer to our users. Your case may be the same mentioned below, then you will quickly find a solution, otherwise, send your questions with a detailed description of the problem to tech support:

3.6. Possible problems and solutions

- Controller is not found in XiLab
- Unable to rotate the motor by the controller
 - Controller has Alarm state
 - Motor vibrates without rotation
 - Mechanical jamming.
- When using the libximc library and Linux with kernel version less than 3.16, there are possible hanging of the operating system

- [Ask a question](#)
- Send an e-mail: 8smc4@standa.it

Controller is not found in XiLab

Solution:

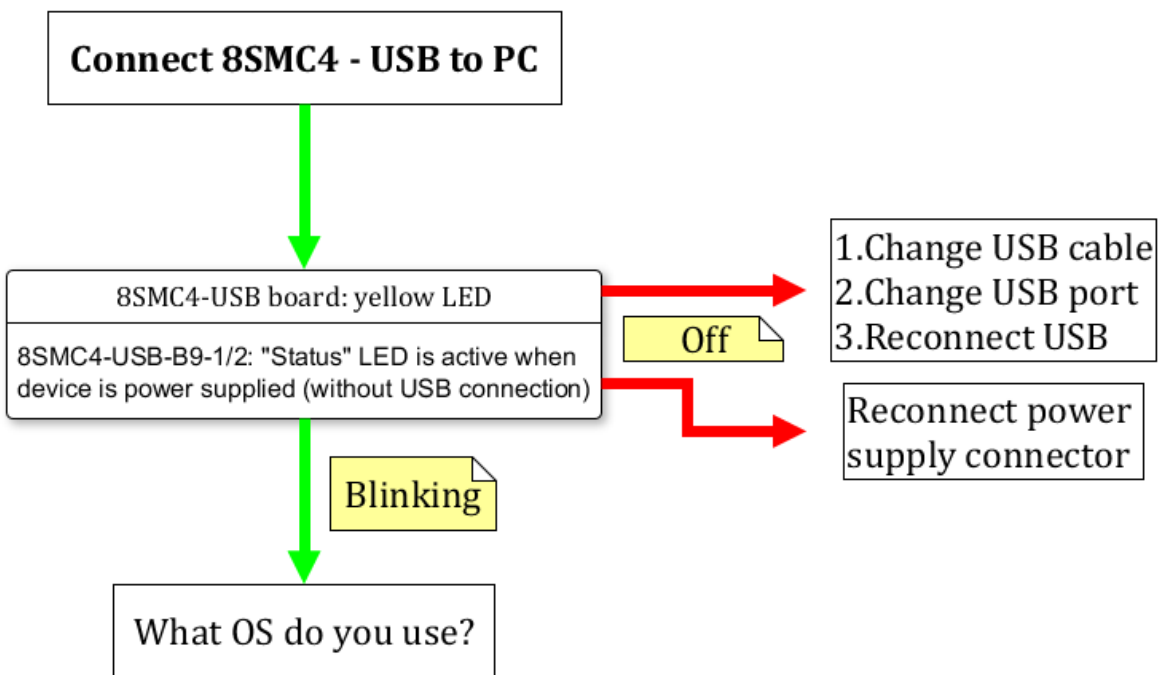

Comment to the diagram:

- [8SMC4-USB-B9-1](#) - one axis system
- [8SMC4-USB-B9-2](#) - two axes system

The following decision maps show the actions for different operating systems.

Windows:

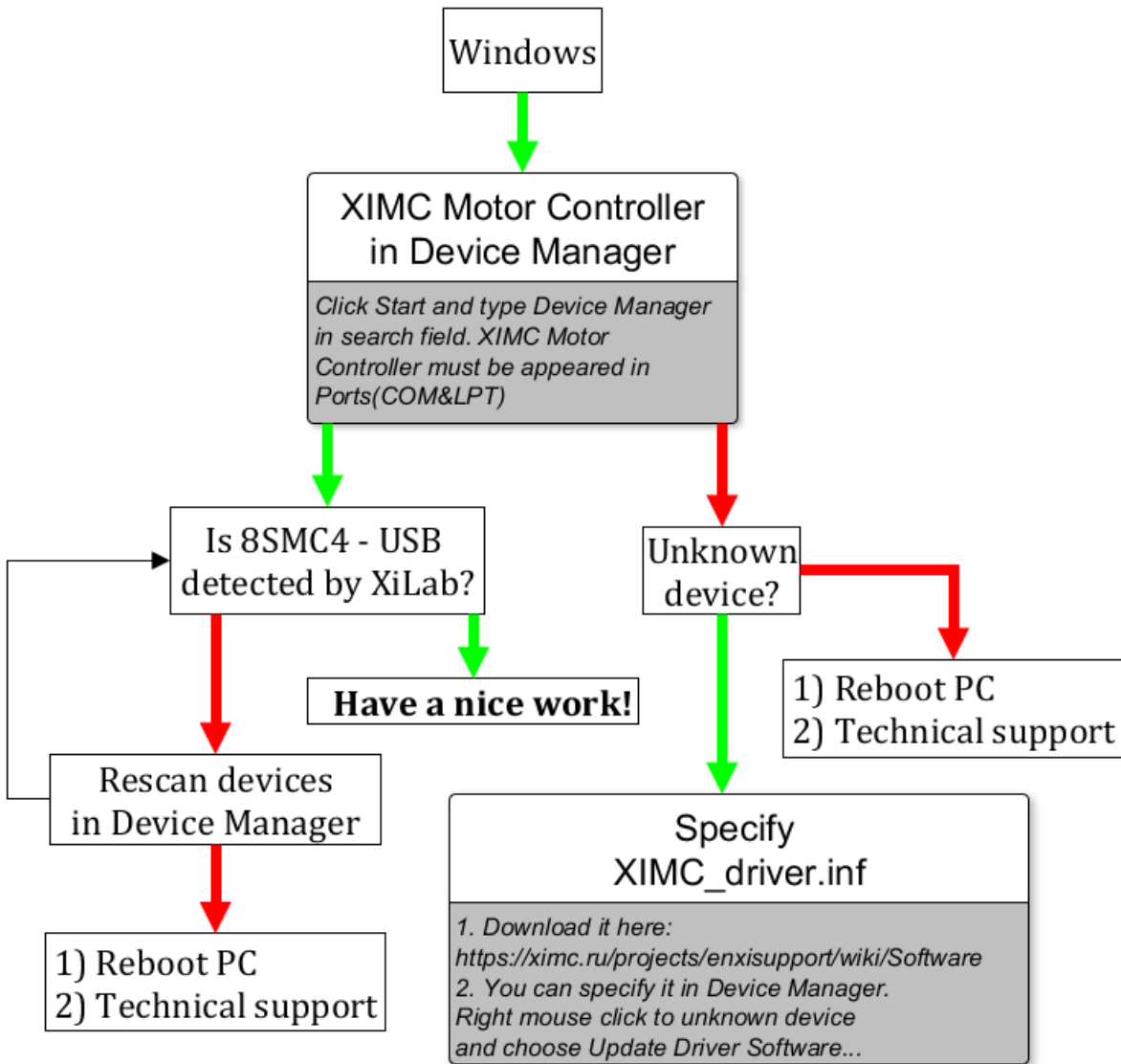

Linux:

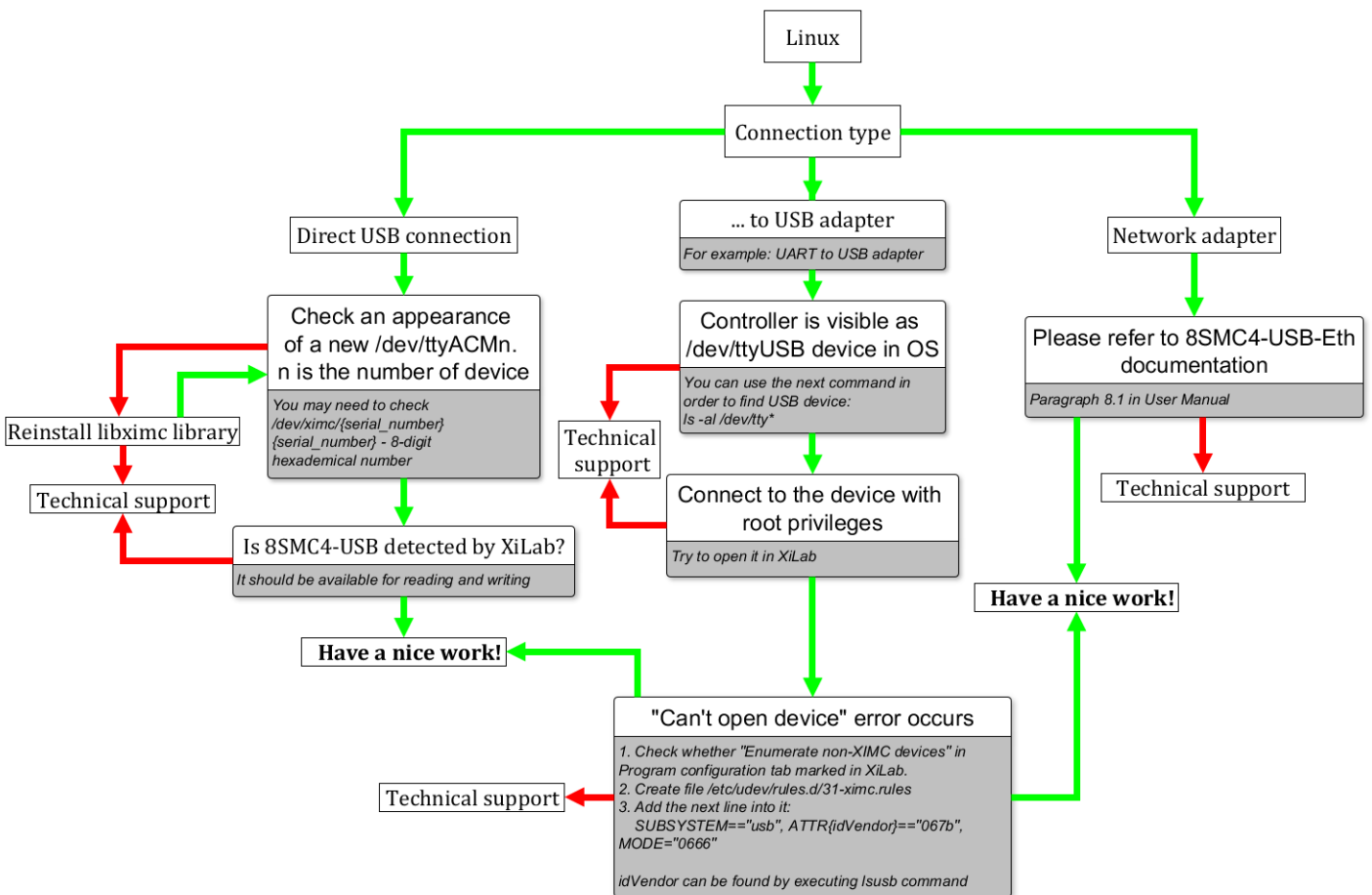

Comment to "Can't open device" problem solution:

When working with USB-... converter in **Linux** it appears as **/dev/ttyUSB** device. XiLab shows it in a list, but when you try to open it, an error "can't open device" occurs due to the lack of permissions to the device.

To solve this problem, create a file: `/etc/udev/rules.d/31-ximc.rules` and add the next line into it:

```
SUBSYSTEM=="usb", ATTR{idVendor}=="067b", MODE="0666"
```

`idVendor` identifier can be found by executing `lsusb` command.

Mac OS:

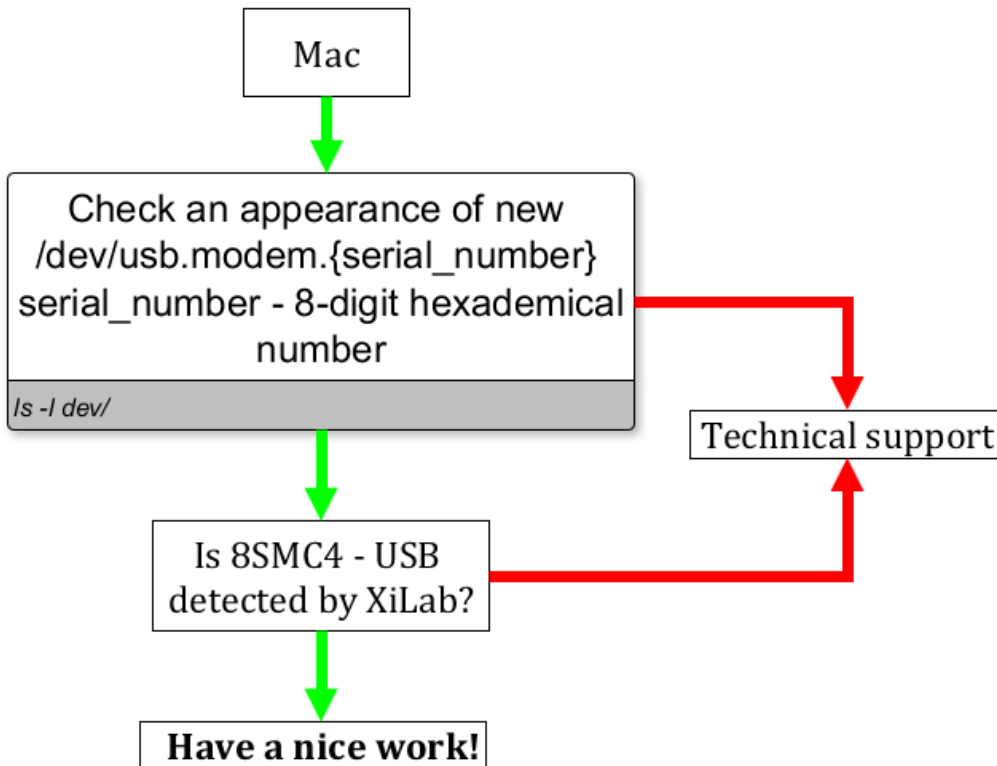

Unable to rotate the motor by the controller

Controller has Alarm state

Click Stop in the main window of XiLab. Controller must return to its normal state. If this approach was not helpful and Alarm state emerged again, do the following:

- Being in XiLab go to the Maximum ratings tab.
- Mark Sticky Alarm flags option. Click OK.
- Press Stop in the main window of XiLab, it will temporary return controller to its normal state. Repeat the sequence of actions leading to Alarm state.
- Make the screenshot of XiLab main window and send it to the technical support with detailed description of your problem.

Motor vibrates without rotation

This problem has several reasons:

- Installed **incorrect profile** for your motor/stage.
 - Search for a better match for the title of profile used by your motorized stage in XiLab folder or refer to [enxisupport](#).
 - It is recommended to save your current configuration to file. To do this, in the Settings window of XiLab click Save to file (see [XiLab settings](#)), choose path where you want to save the settings. Then send this file in technical support with detailed description of the problem.
- **Incorrect configuration of limit switches**, as result the stage rests the limit switch. This can usually be seen by the indicator lights in XiLab.

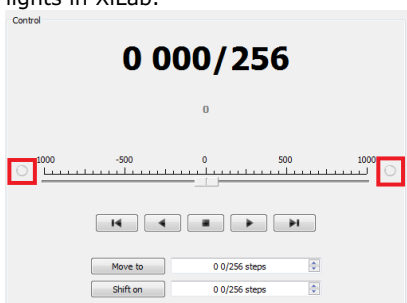

The main reason for the incorrect setting of limit switches is incorrect configuration file for your positioner (see previous item). Information about manual setting is located in [manual profile setting](#). When such problem is emerged it is recommended to contact the technical support for further assistance.

- It is also one of the consequences of problems with limit switches can be **mechanical jamming** (see the next item).
- **Broken winding** of the motor, problems with bad **contact in connector** etc. It is possible to diagnose this kind of problems independently. For this purpose, we recommend to get XiLab graphs of voltage and current during the operation of motor. The

proper motor current in the winding varies according to a sine or cosine. In the broken motor much stronger differences of the current from harmonic form can be noticed.

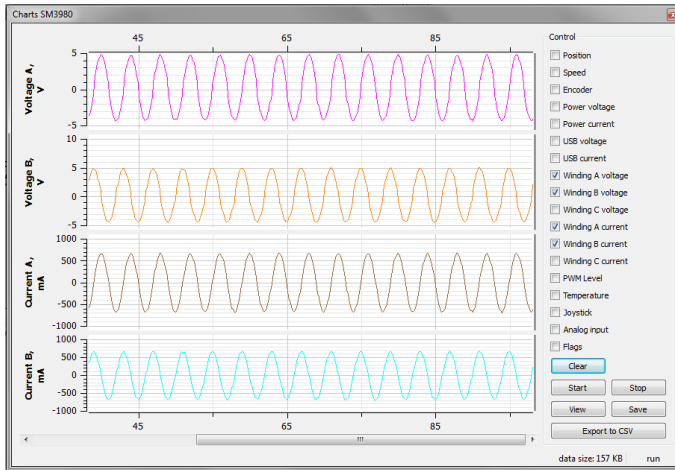

Working case

In the charts below you can see the problems. For example, winding B is open circuit. Probably it is broken. Also, voltage and current forms are distorted.

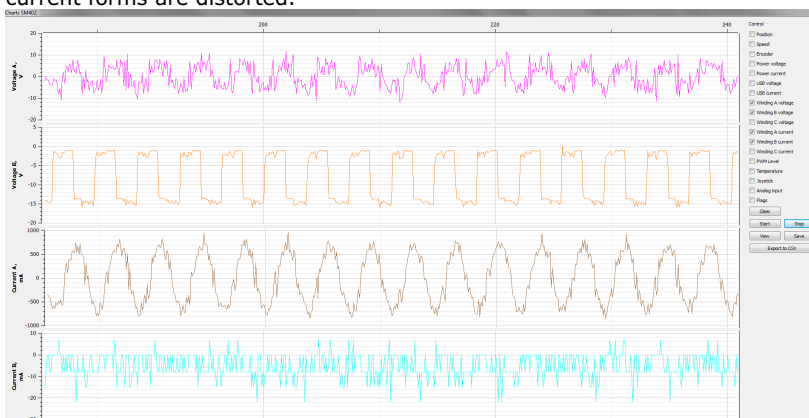

There are problems with motor

To diagnose the problem set very low speed (**1 s/sec** is optimal) and send movement command. Then turn on graphs of current and voltage for windings A and B in XiLab (button **Charts**, then mark correspond fields). Wait for a while until the graphs are built. Then it is recommended to send them (Click **Save** in the same window with graphs) in technical support with a detailed description of the problem. Sometimes, when winding is broken, it is impossible to use XiLab due to permanent loss of device. In this case also contact technical support with description of the problem.

Mechanical jamming.

There are two ways to deal with jamming:

- Turn the motorized stage by hands if it is possible.
- Increase the winding current 2-3 times for a short time (about 5-10 seconds) and send movement command to the stage in the right direction at the low speed (about **50-100 s/sec** will be enough). A few seconds after rotation, press stop button (small black square) until **power off** status appears in the main window of XiLab in order to prevent motor overheating. **After this do not forget to return the settings back!**

When using the libximc library and Linux with kernel version less than 3.16, there are possible hanging of the operating system

Comment: above-mentioned problem stems from the error in serial port driver cdc-acm. It is observed with frequent sequential opening and closing of some devices. Operation system hanging was shown on Debian 7 (3.2 kernel version) and worked correctly on Debian 8 (3.16 kernel version).

For additional information about problem please refer to the next [link](#)

Solution: update your current version of Linux.

4. Technical specification

1. Appearance and connectors
 1. Controller board
 2. Controller board 2.3.X version
 3. One axis system
 4. Two axes system
 5. Multi-axis system
2. Kinematics and rotation modes
 1. Predefined speed rotation mode
 2. Rotation for predefined point
 3. Predefined displacement mode
 4. Acceleration mode
 5. Backlash compensation
 6. Rotation reversal
 7. Recommendations for accurate rotation
 8. PID-algorithm for DC engine control
 9. Stop motion modes
3. Main features
 1. Supported motor types
 2. Motor limiters
 3. Limit switches
 4. Automatic Home position calibration
 5. Operation with encoders
 6. Revolution sensor
 7. Steps loss detection
 8. Power control
 9. Critical parameters
 10. Saving the parameters in the controller flash memory
 11. User defined position units
4. Safe operation
5. Additional features
 1. Operating modes indication
 2. Operations with magnetic brake
 3. Joystick control
 4. Left-Right buttons control
 5. TTL synchronization
 6. Design of multi-axis system
 7. General purpose digital input-output
 8. General purpose analog input
 9. External driver control interface
 10. Serial port
 11. Saving the position in controller's FRAM memory
 12. The Standa stages detection
6. Secondary features
 1. Zero position adjustment
 2. User-defined position adjustment
 3. Controller status
 4. USB connection autorecovery
7. Software compatibility
 1. MicroManager

4.1. Appearance and connectors

8SMC4-USB controllers are available in 4 different versions:

1. [Controller board](#)
2. [Controller board 2.3.X version](#)
3. [One axis system](#)
4. [Two axes system](#)
5. [Multi-axis system](#)

4.1.1. Controller board

Dimensions and arrangement

Structurally the controlled is designed as two boards, 47x75mm each, rigidly connected to each other. A logic controller and control systems are mounted at the bottom board, a power part is at the top board. A radiator at the power part is available.

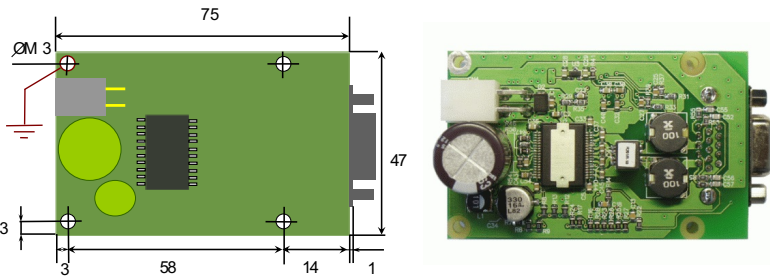

Top view on the controller. The view from power part and radiator side.

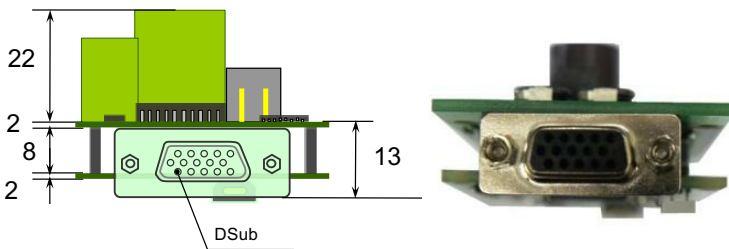

Front view on the controller. The view from stage cable side.

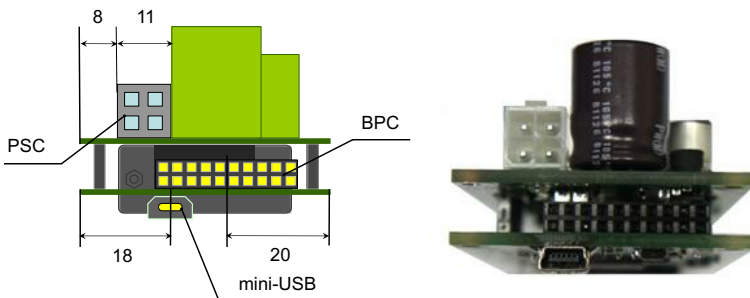

Rear view on the controller. The view from backplane connector side.

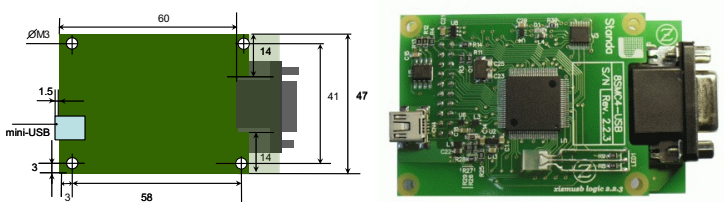

Bottom view on the controller. The view from micro USB port side.

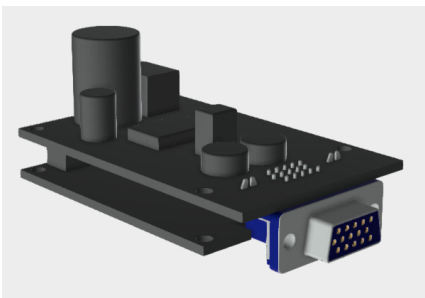

3D view controller.

IMPORTANT. If you are mounting the radiator to the power part by yourself, please make sure that there is no contact between heat-conducting surfaces and conductive elements of the unit. Such contact may damage the power circuit! This warning is applicable only to controllers supplied without body.

Connectors

Positioner connector

A female DSub 15-pin connector for positioner is mounted on the controller board.

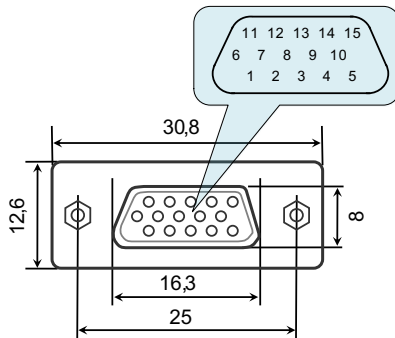

Dimensions and numbers of the pins in DSub connector (front view).

Pins functionality:

- 1 - Not phase B of SM or - DC of the motor
- 2 - Phase B of SM or + DC of the motor
- 3 - Not phase A of SM or - DC of the motor
- 4 - Phase A of SM or + DC of the motor
- 5 - 5V / up to 100mA stabilized output for encoder power supply
- 6 - One-wire interface for positioner identification (for Standa hardware only)
- 7 - Logic ground for limit switches, encoder, etc.
- 8 - 2nd limit switch
- 9 - 1st limit switch
- 10 - Encoder channel A
- 11 - Encoder channel B
- 12 - Revolution sensor input
- 13 - NC for 8SMC4
- 14 - NC for 8SMC4
- 15 - NC for 8SMC4

Note. Outputs 1 & 3 and 2 & 4 must be connected together for proper DC motor function if the nominal current of the motor is higher than 3A.



Warning. Plugging in/out the motor to the controller is not recommended while motor windings are under voltage.

Power supply connector at the board

A male 4-pin Mini-Fit connector with 4.2mm interval (type MF-4MRA) is mounted at the controller board for plugging in to power supply. Its comparable benefits are as following: high 8A current per pin, a fixation available, a possible coupling with both cable-mounted (type MF-4F, PN 39-01-2040 according to Molex catalogue) and board-mounted counterparts, including vertical (PN 15-24-7041 according to Molex catalogue). All Mini-Fit connectors are available in Molex catalogue at www.molex.com.

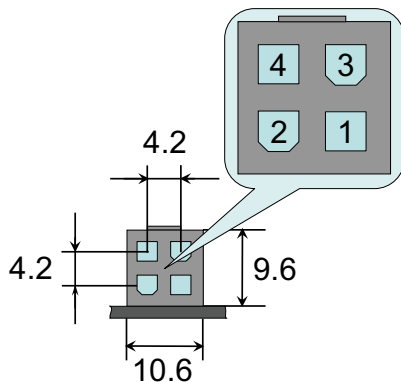

Dimensions and numbers of the pins in PSC (Power Supply Connector), front view.

Pins functionality:

- 1 - "-" power electrode.
- 2 - 12-36V "+" power electrode.
- 3 - "-" power electrode.
- 4 - 12-36V "+" power electrode.

IMPORTANT. Never supply the power to the controller and do not plug it to power connector if you are not confident that your power supply parameters conform to the requirements. Never attempt to plug the power supply to the controller if you are not sure power supply unit and controller connectors are compatible! The acceptable connection parameters are described in [Safety instructions](#).

IMPORTANT. Hot-swapping or unreliable connection of the power supply connector MF-4MRA may damage the PC and/or the controller. For more details please refer to [Safety instructions](#).

Data connector

A mini USB port is mounted at the controller board. It is intended for operating the controller using PC and for power supply in single-axis configuration. While developing the multi-axis systems, a [backplane connector](#) is used instead of mini USB port. The controller port supports a full-speed mode and USB 2.0 specification. Depending on the computer OS device driver installation may be required. For more details please refer to [Overview and getting started](#) and [Software](#).



USB-to-mini-USB cable.



Type B mini-USB connector.

Table of mini USB output pins

Pin #	Name	Wire colour	Description
1	VCC	Red	+5V DC
2	D-	White	Data -
3	D+	Green	Data +
X	ID		N/C
4	GND	Black	Ground



Warning. Use verified USB cables only! Damaged or low-quality USB cable may cause improper controller operation, including motor rotation errors and errors of device recognition by PC operating system. Short cables with thick wires and screening are ideal for sustainable connection.)

Backplane connector

A female 20-pin double-row connector (PBD-20R) with 2.54mm pitch is mounted on the controller board for backplane connection.

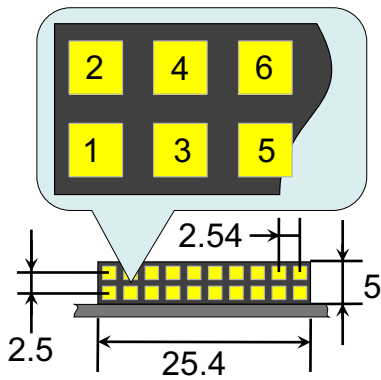

Dimensions and output pins numbers in BPC (BackPlane Connector), connector-side view.

Pin function:

- 1 - GND, duplicates the corresponding pin of [mini USB](#) connector.
- 2 - VBUS, duplicates the corresponding pin of [mini USB](#) connector.
- 3 - D-, duplicates the corresponding pin of [mini USB](#) connector.
- 4 - D+, duplicates the corresponding pin of [mini USB](#) connector.
- 5 - Joy, an analog 0-3 V input used for external [joystick](#) connection.
- 6 - Pot, an analog 0-3 V input used for [general purpose](#).
- 7 - RX, a [serial port](#) input, 3.3V logic.
- 8 - TX, a [serial port](#) output, 3.3V logic.
- 9 - A Clock signal for external driver control, 3.3V logic.
- 10 - A Direction signal for external driver control, 3.3V logic.
- 11 - BUT_R, an external "[Right](#)" [button](#) input.
- 12 - BUT_L, an external "[Left](#)" [button](#) input.
- 13 - A common input/output (or an Enable signal if an external driver is used), 3.3V logic.
- 14 - An output for magnetic brake control, 3.3V logic.
- 15 - Synchronization output, 3.3V logic.
- 16 - Synchronization input, 3.3V logic.
- 17 - A LED Power output displaying 3.3V power supply for controller.
- 18 - A LED Status output displaying controller's operating mode.
- 19 - A LED output for left limit switch.
- 20 - A LED output for right limit switch.

Note. No additional connection or pull-up to ground/power supply is required for idle pins. Just don't use them.

IMPORTANT. A maximum designed operating voltage for Joy and Pot analog inputs is UP TO 3V. Never supply these inputs with higher voltage, including 3.3V value, otherwise the proper operation of all the analog channels of the controller may get disrupted and the controller itself or the motor may get damaged.

IMPORTANT. The outputs available at the internal connector are not protected. Mounting of any additional buffers or filtering chains is a total responsibility of user or developer who designs a backplane intended to use these lines.

IMPORTANT. While the controller is unpowered, no voltage over 0.3V relative to the DGND pin is allowed on the internal connector. Provision of any additional protection preventing those accidents (if possible) is a total responsibility of user or developer who designs a backplane intended to use these lines.

4.1.3. One axis system

Enclosure view



Front panel of the single-axis controller model 8SMC4-USB-B8-1.



Rear panel of the single-axis controller model 8SMC4-USB-B8-1.

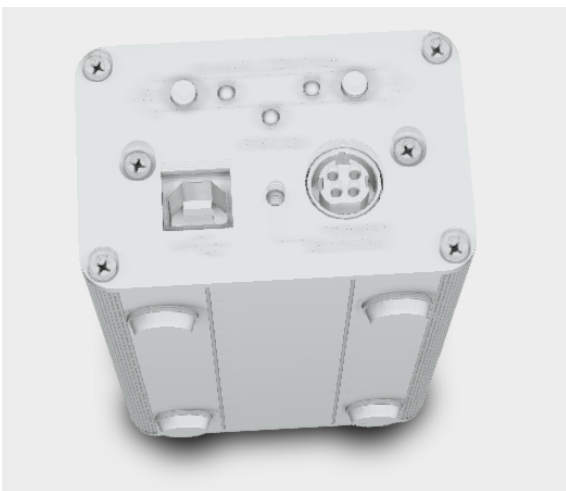

The controller in a metal case, a uniaxial variant of 3D (model 8SMC4-USB-B8-1).

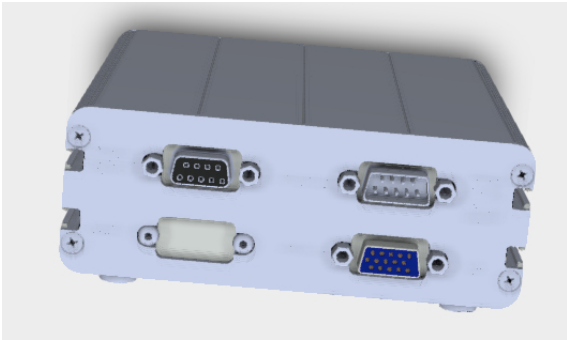

The controller in a metal case, a uniaxial variant of 3D (model 8SMC4-USB-B9-1).

Single-axis controller model is a [controller board](#) in a metal case. Case dimensions are 66 x 46 x 114 mm.

Front panel of the controller contains [power supply connector](#), [USB-B data connector](#), status LED, power LED, left and right limit switch LEDs, left and right movement buttons.

Rear panel contains [positioner connector](#) and [synchronization connector](#).

Connectors

Positioner connector

A female DSub 15-pin connector for positioner is mounted on the controller board.

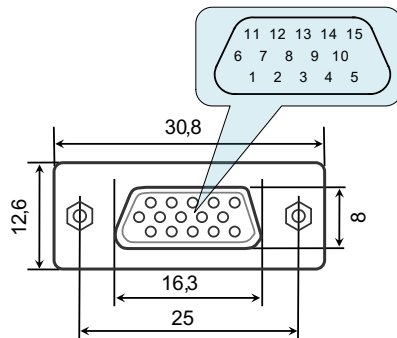

Dimensions and numbers of the pins in DSub connector (front view).

Pins functionality:

- 1 - Not phase B of SM or - DC of the motor
- 2 - Phase B of SM or + DC of the motor
- 3 - Not phase A of SM or - DC of the motor
- 4 - Phase A of SM or + DC of the motor
- 5 - 5V / up to 100mA stabilized output for encoder power supply
- 6 - One-wire interface for positioner identification (for Standa hardware only)
- 7 - Logic ground for limit switches, encoder, etc.
- 8 - 2nd limit switch
- 9 - 1st limit switch
- 10 - Encoder channel A
- 11 - Encoder channel B
- 12 - Revolution sensor input
- 13 - NC for 8SMC4
- 14 - NC for 8SMC4
- 15 - NC for 8SMC4

Note. Outputs 1 & 3 and 2 & 4 must be connected together for proper DC motor function if the nominal current of the motor is higher than 3A.



Warning. Plugging in/out the motor to the controller is not recommended while motor windings are under voltage.

Power supply connector. 1 and 2 axes system

One- and two-axis controller models in metal cases use Kycon 4-pin DC power connector (part number KPPX-4P, anacapa.kycon.com).

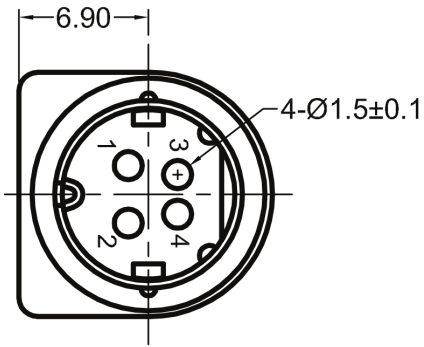

Pinout:

- 1 - Power, "-".
- 2 - Power, "+". 12-36V.
- 3 - Power, "-".
- 4 - Power, "+". 12-36V.

IMPORTANT. Never supply the power to the controller and do not plug it to power connector if you are not confident that your power supply parameters conform to the requirements. Never attempt to plug the power supply to the controller if you are not sure power supply unit and controller connectors are compatible! The acceptable connection parameters are described in [Safety instructions](#).

IMPORTANT. Hot-swapping or unreliable connection of the power supply connector MF-4MRA may damage the PC and/or the controller. For more details please refer to [Safety instructions](#).

Data connector. 1 and 2 axes system

Controllers in metal case connect via USB type-B connector.



USB-A - USB-B cable.



USB type B connector.

Output pin table

Pin #	Name	Wire color	Description
1	VCC	Red	+5 VDC
2	D-	White	Data -
3	D+	Green	Data +
4	GND	Black	Ground

Warning. Use verified USB cables only! Damaged or low-quality USB cable may cause improper controller operation, including motor rotation errors and errors of device recognition by PC operating system. Short cables with thick wires and screening are ideal for sustainable connection.)

Synchronization connector

A single-axis or two-axis controller model may contain a synchronization and magnetic brake 9pin DSub female connector.

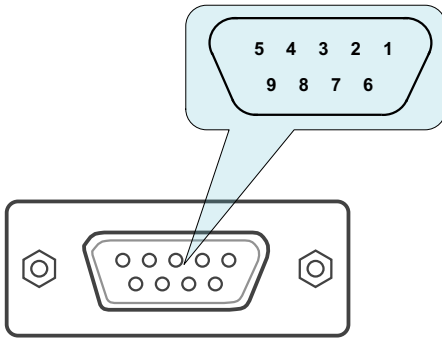

Pinout of the connector, front view.

Pinout:

- 1 - Magnetic brake output, axis 1, +24V.
- 2 - Synchronization input, axis 2, 3.3V logic.
- 3 - Synchronization input, axis 1, 3.3V logic.
- 4 - Unused.
- 5 - GND, ground pin.
- 6 - Magnetic brake output, axis 2, +24V.
- 7 - Synchronization output, axis 2, 3.3V logic.
- 8 - Synchronization output, axis 1, 3.3V logic.
- 9 - GND, ground pin.

Note. If the connector belongs to a single-axis model, then pins 2, 6, 7 are not used.

Note. In case magnetic brake control board is not connected, then pins 1 and 6 are not used.

Note. Unused pins of the internal connector do not require any additional connection or pullup/pulldown. Simply do not use them.

4.1.4. Two axes system

Enclosure view



Front panel of the two-axis controller model 8SMC5-USB-B9-2.



Rear panel of the two-axis controller model 8SMC5-USB-B9-2.

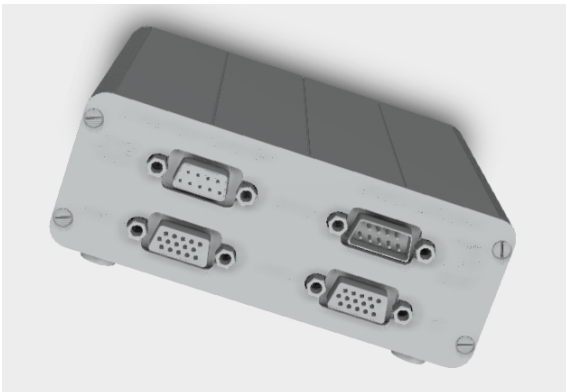

The controller in a metal case of the biaxial variant 3D (model 8SMC4-USB-B9-2).

Two-axis controller model consists of two [controller boards](#) in a metal case. Case dimensions are 122 x 48.5 x 124 mm. Front panel contains [power supply connector](#), [USB-B data connector](#), [supplementary two-axis system connector](#), USB cascade connector, and power LED. The cascade USB-A output connector is used to connect several two-axis cases in line terminated with either one-axis or two-axis case. This way a required number of axes can be connected to the computer with a single USB cable. The front panel also contains status LED, left and right limit switch LED, left and right movement buttons for each of the two controller boards of the two-axis system.

Rear panel contains [positioner connector](#) for each of the two controller boards, a [synchronization connector](#) and a [joystick connector](#).

Connectors

Positioner connector

A female DSub 15-pin connector for positioner is mounted on the controller board.

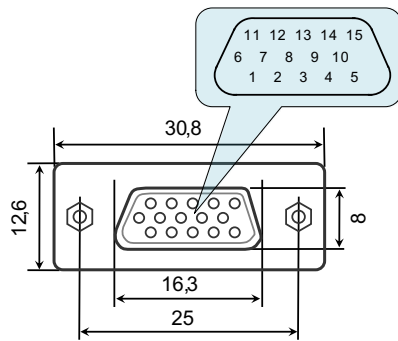

Dimensions and numbers of the pins in DSub connector (front view).

Pins functionality:

- 1 - Not phase B of SM or - DC of the motor
- 2 - Phase B of SM or + DC of the motor
- 3 - Not phase A of SM or - DC of the motor
- 4 - Phase A of SM or + DC of the motor
- 5 - 5V / up to 100mA stabilized output for encoder power supply
- 6 - One-wire interface for positioner identification (for Standa hardware only)
- 7 - Logic ground for limit switches, encoder, etc.
- 8 - 2nd limit switch
- 9 - 1st limit switch
- 10 - Encoder channel A
- 11 - Encoder channel B
- 12 - Revolution sensor input
- 13 - NC for 8SMC4
- 14 - NC for 8SMC4
- 15 - NC for 8SMC4

Note. Outputs 1 & 3 and 2 & 4 must be connected together for proper DC motor function if the nominal current of the motor is higher than 3A.



Warning. Plugging in/out the motor to the controller is not recommended while motor windings are under voltage.

Power supply connector. 1 and 2 axes system

One- and two-axis controller models in metal cases use Kycon 4-pin DC power connector (part number KPPX-4P, anacapa.kycon.com).

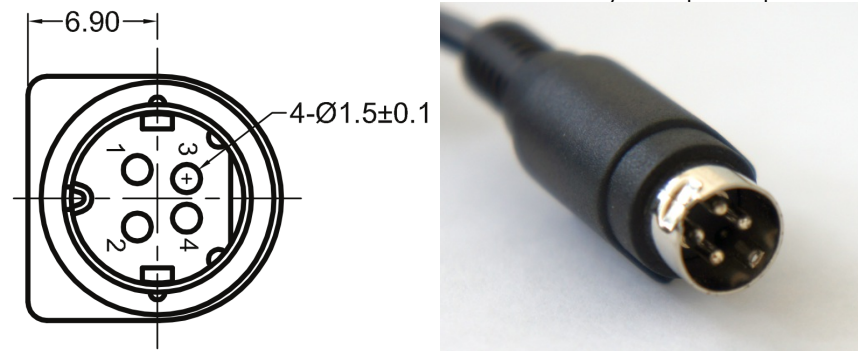

Pinout:

- 1 - Power, "-".
- 2 - Power, "+". 12-36V.
- 3 - Power, "-".
- 4 - Power, "+". 12-36V.

IMPORTANT. Never supply the power to the controller and do not plug it to power connector if you are not confident that your power supply parameters conform to the requirements. Never attempt to plug the power supply to the controller if you are not sure power supply unit and controller connectors are compatible! The acceptable connection parameters are described in [Safety instructions](#).

IMPORTANT. Hot-swapping or unreliable connection of the power supply connector MF-4MRA may damage the PC and/or the controller. For more details please refer to [Safety instructions](#).

Data connector. 1 and 2 axes system

Controllers in metal case connect via USB type-B connector.



USB-A - USB-B cable.



USB type B connector.

Output pin table

Pin #	Name	Wire color	Description
1	VCC	Red	+5 VDC
2	D-	White	Data -
3	D+	Green	Data +
4	GND	Black	Ground

Warning. Use verified USB cables only! Damaged or low-quality USB cable may cause improper controller operation, including motor rotation errors and errors of device recognition by PC operating system. Short cables with thick wires and screening are ideal for sustainable connection.)

Joystick connector

A single-axis or two-axis controller model may contain a 9pin DSub male joystick connector.

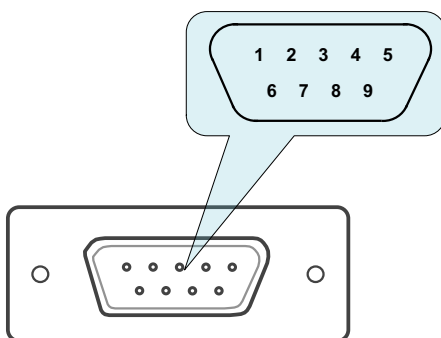

Pinout of the joystick connector, front view.

Pinout:

- 1 - BUT_R_1, [right button](#) input, axis 1.
- 2 - Joy_2, analog 0-3V [joystick](#) input, axis 2.
- 3 - GND, common ground.
- 4 - BUT_R_2, [right button](#) input, axis 2.
- 5 - GND, common ground.
- 6 - Joy_1, analog 0-3V [joystick](#) input, axis 1.
- 7 - 3.3V output.
- 8 - BUT_L_1, [left button](#) input, axis 1.
- 9 - BUT_L_2, [left button](#) input, axis 2.

Note. If the connector belongs to a single-axis model, then pins 2, 4, 9 are not used.

Note. Unused pins of the internal connector do not require any additional connection or pullup/pulldown. Simply do not use them.

IMPORTANT. Analog Joy, Pot inputs are designed to work with LESS THAN 3V voltage. Do not apply higher voltages, including 3.3V, to these inputs, as it can break all analog controller inputs and lead to the controller or motor failure.

Synchronization connector

A single-axis or two-axis controller model may contain a synchronization and magnetic brake 9pin DSub female connector.

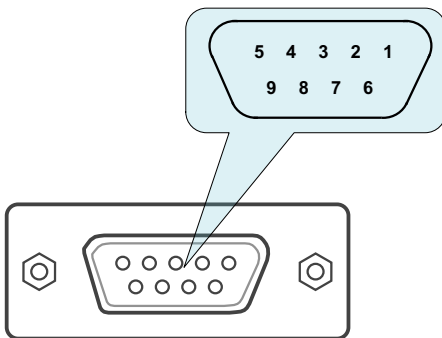

Pinout of the connector, front view.

Pinout:

- 1 - Magnetic brake output, axis 1, +24V.
- 2 - Synchronization input, axis 2, 3.3V logic.
- 3 - Synchronization input, axis 1, 3.3V logic.
- 4 - Unused.
- 5 - GND, ground pin.
- 6 - Magnetic brake output, axis 2, +24V.
- 7 - Synchronization output, axis 2, 3.3V logic.
- 8 - Synchronization output, axis 1, 3.3V logic.
- 9 - GND, ground pin.

Note. If the connector belongs to a single-axis model, then pins 2, 6, 7 are not used.

Note. In case magnetic brake control board is not connected, then pins 1 and 6 are not used.

Note. Unused pins of the internal connector do not require any additional connection or pullup/pulldown. Simply do not use them.

Supplementary two-axis system connector

Two-axis controller model contains a HDB-26 female DSub connector.

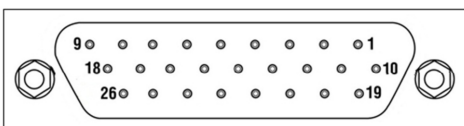

Pinout of the supplementary HDB-26 connector, front view.

Pinout:

- 1 - RX_2, serial port input, axis 2.
- 2 - NC, not used.
- 3 - TX_2, serial port output, axis 2.
- 4 - GND, ground.
- 5 - NC, not used.
- 6 - NC, not used.
- 7 - NC, not used.
- 8 - RX_1, serial port input, axis 1.
- 9 - NC, not used.
- 10 - CLK_1, Clock signal for the external driver, axis 2.
- 11 - POT_2, [analog input](#), axis 2
- 12 - IO_2, input-output pin, axis 2.
- 13 - DIR_1, Direction signal for the external driver, axis 1.
- 14 - GND, ground.
- 15 - +5V.
- 16 - BRAKE_1, brake control output, axis 1.
- 17 - CLK_1, Clock signal for the external driver, axis 1.
- 18 - TX_1, serial port output, axis 1.
- 19 - DIR_2, Direction signal for the external driver, axis 1.
- 20 - BRAKE_2, brake control output, axis 2
- 21 - PBRK_2, Magnetic brake output, axis 2.
- 22 - GND, ground.
- 23 - PBRK_1, Magnetic brake output, axis 1.
- 24 - +5V.
- 25 - IO_1, input-output pin, axis 1.
- 26 - POT_1, [analog input](#), axis 1.

4.1.5. Multi-axis system

Enclosure view

Multi-axis version of motor controller is 7U design with handles for setting on usual 19' industrial cabinet. It contains up to 36 [controllers boards](#). Every 4 boards combined together in 1 module. Device dimensions: 445 x 375 x 311 mm.



Front pannel divided by 9 parts with titles: "Module 1", "Module 2",..., "Module 9". Every such module contains [indication signals](#) "Power" and "Status" for every axis inside module and "[External control](#)" connector.

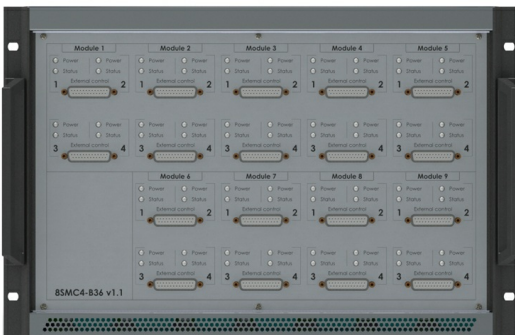

Back pannel contains 220 V connector, Ethernet socket, on/off power button and 4 [positioner connectors](#) for every module. Total quantity of position connectors is 36.



Every module can be plugged/unplugged during multi-axis system works. To unplug module it is needed to unscrew the screws with corrugated heads and pull the handle.

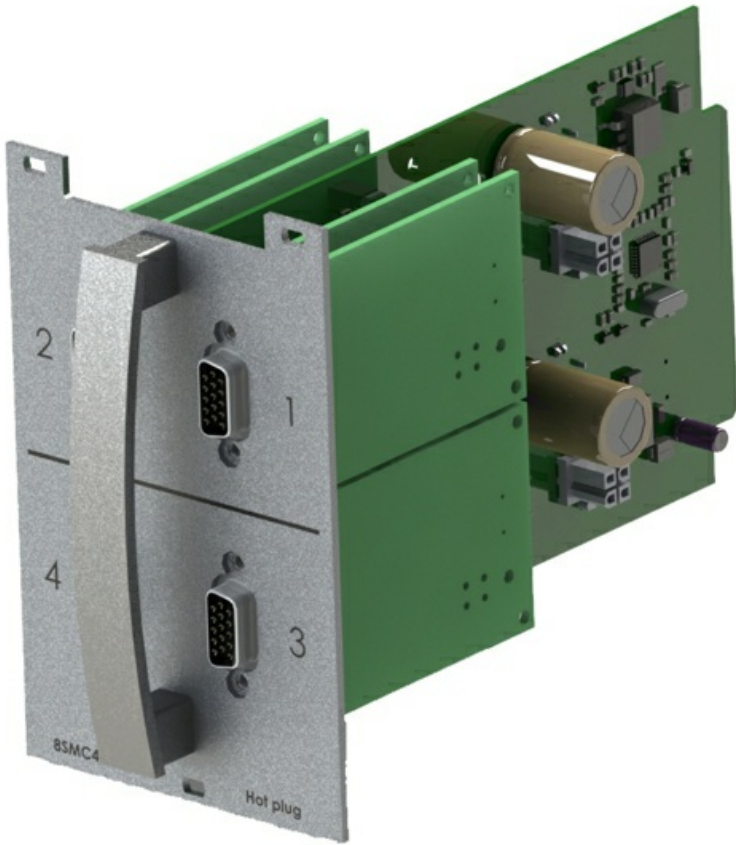

Schematic view of module

Dimensions

Structurally multi-axis system is designed as 7U box with handles for setting on usual 19' industrial cabinet.

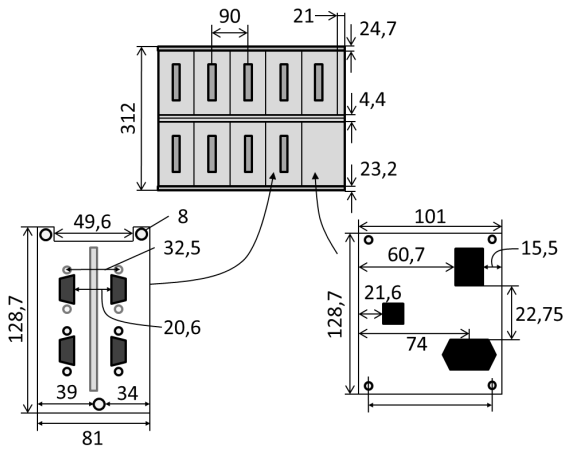

Back view of multi-axis system. View from 220V power connector and control modules side.

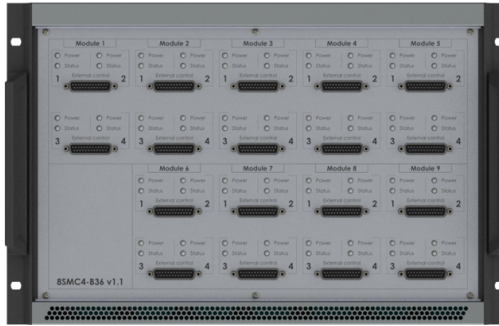
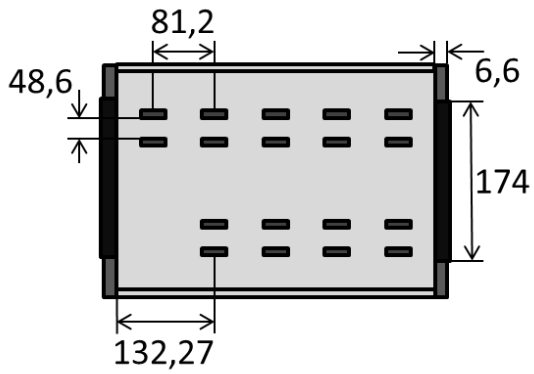

Front view of multi-axis system. View from external connectors side.

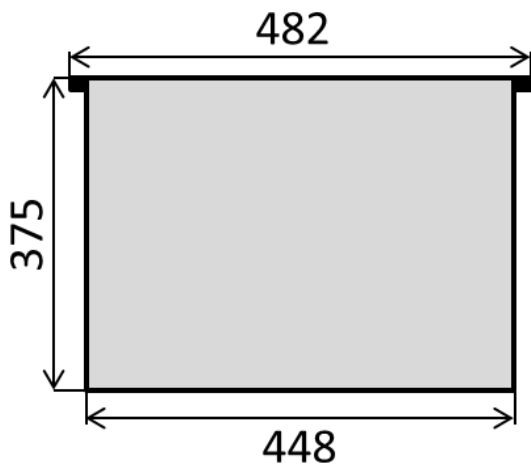

Top view of multi-axis system.

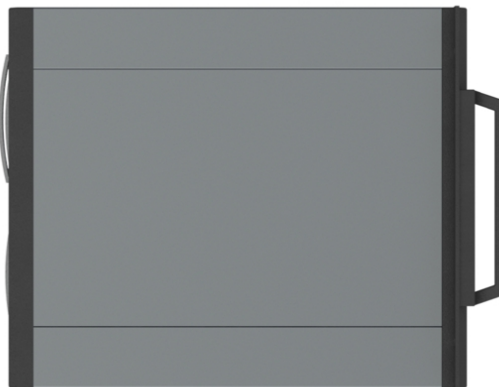
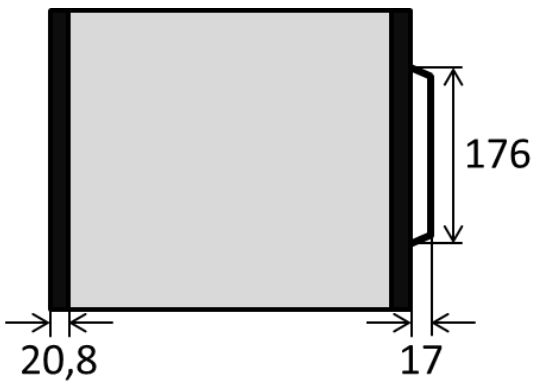

Side view of multi-axis system.

Connectors

Positioner connector

A female DSub 15-pin connector for positioner is mounted on the controller board.

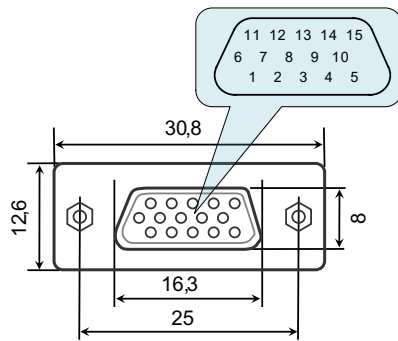

Dimensions and numbers of the pins in DSub connector (front view).

Pins functionality:

- 1 - Not phase B of SM or - DC of the motor
- 2 - Phase B of SM or + DC of the motor
- 3 - Not phase A of SM or - DC of the motor
- 4 - Phase A of SM or + DC of the motor
- 5 - 5V / up to 100mA stabilized output for encoder power supply
- 6 - One-wire interface for positioner identification (for Standa hardware only)
- 7 - Logic ground for limit switches, encoder, etc.
- 8 - 2nd limit switch
- 9 - 1st limit switch
- 10 - Encoder channel A
- 11 - Encoder channel B
- 12 - Revolution sensor input
- 13 - NC for 8SMC4
- 14 - NC for 8SMC4
- 15 - NC for 8SMC4

Note. Outputs 1 & 3 and 2 & 4 must be connected together for proper DC motor function if the nominal current of the motor is higher than 3A.



Warning. Plugging in/out the motor to the controller is not recommended while motor windings are under voltage.

Power supply connector. Multi-axis system

Multi-axis system consumes 220 V via IEC connector.



Pins functionality:

- N - "zero"
- E - "ground"
- L - "phase"

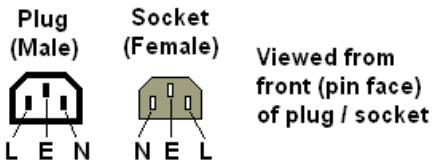

Data connector. Multi-axis system

Multi-axis system can control up to 36 axes via Ethernet simultaneously. It uses RJ45 connector with "female" type:



Pins functionality:

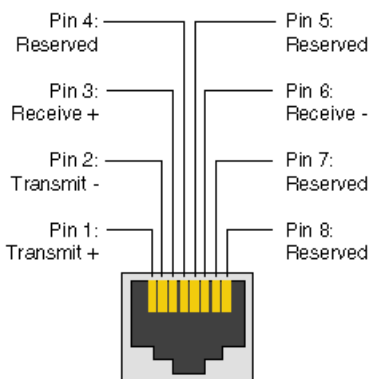

Supplementary multiaxis system connector

This connector placed on the front panel of the multiaxis system and named as *External control*. There are total 18 such connectors. This connectors are useful for control motors by external devices such as joystick or buttons. Also power, status and border indicators are routed to this connector.

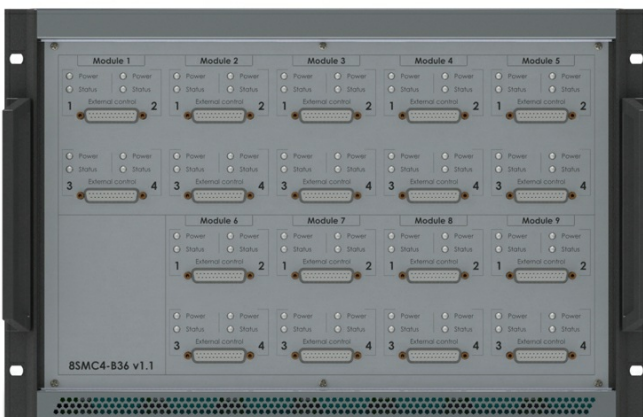

Appearance of the front panel.

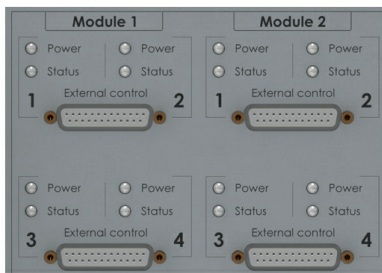

Scaled view of the two modules.

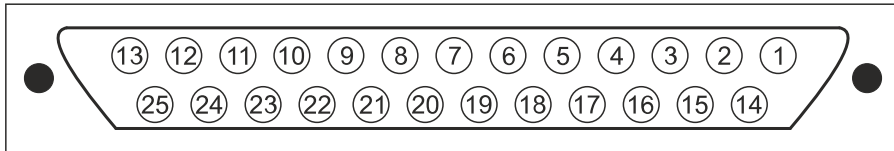

Appearance and pin-numbers of DB-25 connector (front view).

Pin function:

- 1 - PWRLED1, [power indicator LED](#) of the controller 1.
- 2 - LEFTEDGE1, [left border indicator](#) of the controller 1.
- 3 - LEFTBUTTON1, [left button input](#) of the the controller 1.
- 4 - JOY1, [joystick input](#) of the controller 1.
- 5 - NC, not connected.
- 6 - +5VP, output +5V.
- 7 - SYNCOUT, [synchronization output](#) of the module.
- 8 - GND, ground.
- 9 - NC - not cnnected.
- 10 - JOY2, [joystick input](#) of the controller 2.
- 11 - LEFTBUTTON2, [left button input](#) of the controller 2.
- 12 - LEFTEDGE2, [left border indicator](#) of the controller 2.
- 13 - PWRLED2, [power indicator LED](#) of the controller 2.
- 14 - STS1, [status indicator LED](#) of the controller 1.
- 15 - RIGHTEGE1, [right border indicator](#) of the controller 1.
- 16 - RIGHTBUTTON1, [right button input](#) of the controller 1.
- 17 - NC, not connected.
- 18 - NC, not connected.
- 19 - SYNCIN, [synchronization input](#) of the module.
- 20 - +3V, output +3V.
- 21 - NC, not connected.
- 22 - NC, not connected.
- 23 - RIGHTBUTTON2, [right button input](#) of the controller 2.
- 24 - RIGHTEGE2, [right border indicator](#) of the controller 2.
- 25 - STS2, [status indicator LED](#) of the controller 2.

Note. The synchronization output goes to the hi-level state if the synchronization outputs of the all 4 controllers in the hi-level state and the synchronization input of the module in the hi-level state.

Note. If the synchronization input is not connected, it pulls up to the hi-level state by the internal pull-up resistor.

4.2. Kinematics and rotation modes

1. [Predefined speed rotation mode](#)
2. [Rotation for predefined point](#)
3. [Predefined displacement mode](#)
4. [Acceleration mode](#)
5. [Backlash compensation](#)
6. [Rotation reversal](#)
7. [Recommendations for accurate rotation](#)
8. [PID-algorithm for DC engine control](#)
9. [Stop motion modes](#)
10. [PID-algorithm for BLDC engine control](#)

4.2.1. Predefined speed rotation mode

[Predefined speed rotation mode](#) is the main operating mode of the controller for all the motor types. It allows to maintain the predefined rotation speed at a distance from the destination point and is usually used simultaneously with [Rotation for predefined point](#) or [Predefined displacement](#) modes. This mode may also get called by left and right motion commands.

Motor steps or [encoder](#) counts (if the encoder is available) per time unit are used as speed measurement units. Encoders work with all the types of motors. For DC motors the fixed speed is maintained even with the variable external load.

Turning on the [Acceleration mode](#) temporarily deactivates the [predefined speed rotation mode](#).

After the controller receives the command to start the motion, it rotates the motor with user-defined speed. **The speed adjustment is available** at the [appropriate section of the "Settings..." menu of XILab software](#) or using the `set_move_settings()` function (refer to [Programming guide](#) section). For stepper motors the **speed value** may be defined in full steps and microsteps per second, for DC motors the speed is defined in revolutions per minute (RPM).

The speed for special motion modes, e.g., for [backlash compensation](#) or [automatic zero position calibration](#), is different from the general rotation speed and is set separately.

The controller allows limitation of the maximum speed if appropriate parameter is defined by user. In that case any rotation that would have happened with the speed over the maximum is performed with the maximum speed. A separate adjustment is available, providing use of the maximum speed for all the ordinary motion modes, except for special ones, e.g., [backlash compensation](#) or [automatic zero position calibration](#). The maximum speed adjustment as well as the adjustment for modes using this speed are available in the [appropriate section of the "Settings..." menu of XILab software](#).

The **actual speed** is displayed in [XILab main window](#), in the [Speed](#) field, or on [main operating parameters charts](#).

Note. If the **stability of the speed maintenance** seems to be insufficient while the [encoder](#) is used, please refer to [recommendations for accurate rotation](#).

Note. Maximum allowed speed is **100000 steps/s** or **100000 rpm** depending on engine type.

4.2.2. Rotation for predefined point

The [rotation to predefined point](#) mode is the main operating mode for all the types of motors and is usually used simultaneously with [predefined speed rotation mode](#). It provides moving the stage to the defined position with **absolute value** for destination point coordinates which is different from [predefined displacement mode](#). An additional reciprocal motion close to predefined point may be performed at [Backlash compensation](#) mode.

While using the [encoder](#), few barely noticeable "vibrations" are possible before the motor stops in predefined point.

After the starting command is received by the controller, it either switches on the [acceleration mode](#) (if the appropriate option is on) or immediately starts rotating the shaft of the motor with user-defined speed. After the predefined point is reached, the rotation stops; [deceleration](#) may be activated if the appropriate option is on. The **destination point** is set in [XILab main window](#). The **destination point** may be defined either in full steps and microsteps for stepper motors or in [encoder](#) counts for all types of motors.

The **actual position** is displayed in [XILab main window](#), in the [Control](#) section, or on [main operating parameters charts](#).

Note. If the **positioning accuracy** seems to be insufficient while the [encoder](#) is used, please refer to [recommendations for accurate rotation](#).

4.2.3. Predefined displacement mode

The [predefined displacement mode](#) provides displacement of the stage for predefined value relative to zero position (if this is a first command since the controller started) or relative to position reached by the motor after the previous commands are completed, i.e., the destination point coordinate is a **relative value**. This mode is useful when the absolute position is unknown or doesn't matter.

The [predefined displacement mode](#) is exactly analogous to [rotation for predefined point](#) mode. The differences concern the destination position computing rules only. While there is no motion actually, calling the [predefined displacement](#) command rotates the motor relatively to current position. If this command is sent during the rotation to the position (*MOVE*, *MOVR*, *SSTP*, *STOP*, *LOFT*), then the displacement interval adds to destination position and the controller re-adjusts for the new destination point while the motor is rotating. If this command comes during the rotation for certain direction, then the displacement value adds to previous destination position and the motion automatically re-adjusts for the new position.

IMPORTANT. The displacement is always performed relative to position reached by stage while performing one of the previous command, *MOVE*, *MOVR*, *SSTP*, *STOP*, *LOFT*, or while performing the displacement after the previous incoming synchronization pulse has been received, despite whether the motion has been completed or interrupted.

Note. The predefined displacement mode is activated either by corresponding command or by incoming synchronization pulse. For more information please refer to [TTL synchronization](#) chapter.

4.2.4. Acceleration mode

The [acceleration](#) function is active **by default**. The [acceleration](#) is used for smooth start or finish of the rotation without shocks that are inevitable when the predefined speed is reached instantly. Moreover, inertia of rotor and the other components of stage usually doesn't allow instant gathering of high speed which results in the loss of steps as well as failure in rotation during the operation without feedback. While operating the motor with feedback via encoder, the speed will increase as quickly as [motor limiters](#) allow. High acceleration makes the rotation unstable as well as it makes more noise and vibration. That's why the acceleration mode is recommended. The [acceleration](#) function provides reaching of both maximum speed and sustainable motion even for motors with intermediate torque value.

The [acceleration/deceleration](#) mode works in the following way: during the speeding-up, while the required speed value is higher than the actual one, a gradual acceleration is performed at the [Acceleration](#) value which is measured in steps per squared second. After the required speed is reached, the controller switches to [predefined speed rotation](#) mode. Approaching the destination position, the controller begins to decrease the speed as the speeding-down would equal to [Deceleration](#) value and the motor would stop exactly at the destination point. Thus, this mode provides a trapezoidal speed profile. If the displacement distance is small, then the acceleration may change directly to deceleration; this will result to triangular speed profile. Turning the acceleration mode on and off, as well as setting of acceleration and deceleration value, is possible using XiLab software (see the [Settings of kinematics \(Stepper motor\)](#) section) or by [set_move_settings\(\)](#) command described in [Programming guide](#).

The [Acceleration](#) value is adjusted independently from the [Deceleration](#) value – and there is a reason for it. Usually, due to friction effect resisting acceleration but contributing to deceleration, the maximum acceleration value is less than deceleration one. Therefore, for the fastest response of the stage either preset profiles should be used, or the acceleration/deceleration values should be established experimentally, according to what your stage may provide. For stepper motors working without feedback these are the values that do not lead to the steps loss. For motors with feedback the trapezoidal speed profile should be controlled using [XiLab charts](#). The acceleration/deceleration values should be taken 1.5–2 times less than those resulting in speed profile distortion or step loss.

Note. Turning the acceleration/deceleration mode off is sometimes useful for multiaxis systems control where, during the motion along multi-dimensional paths, a continuous speed projection on each of the axes is required.

Note. The acceleration value is not displayed in [XiLab main window](#).

Note. Acceleration/deceleration values should be set as to allow the motor to reach target speed or decelerate from top speed to zero in less than **5 minutes**. If the acceleration/deceleration on [kinematic settings](#) page is set outside of this range, then the controller will return an "incorrect value" error and acceleration/deceleration will be changed in controller to applicable value.

4.2.5. Backlash compensation

Backlash occurs in any mechanical device, e.g., in reduction gear or in worm-gear. Backlash results in differences in physical stage position when approaching the same point from different directions, whereas the motor shaft is exactly in the required position.

Backlash compensation mode is used in order to eliminate such ambiguity. Its activation allows user to determine the direction from where the stage would approach the destination point. Further on, the stage will approach the stop point from the defined direction only, eliminating the mechanical backlash. If the natural approaching direction doesn't match the selected one, then the controller drives the motor for some user-defined distance beyond the destination point and after that turns the motor around and completes the approach from the required direction.

While a loaded mechanical system is moving, its dynamic characteristics in the backlash zone do differ from the regular motion mode. Therefore, the rotation in the backlash zone should be performed with user-defined speed.

The following parameters of backlash-compensating system are available for adjustment by user:

- Backlash compensation on/off flag.
- Rotation speed while performing the compensating motion.
- Backlash compensation distance. The plus or minus sign for that parameter is used to determine the approach direction. The plus means the approach from the left side whereas the minus means the approach from the right side.

The controller indicates if the backlash compensation is active using `MOVE_STATE_ANTIPLAY` flag in the state structure which is also displayed in [XILab main window](#).

A forced backlash compensation by using the `LOFT` command may be performed if there is no confidence that the actual position is backlash-free. While carrying out this command, a displacement for backlash compensation distance is performed with subsequent return. Calling this command while driving will lead to a smooth stop of the engine. This command makes sense only when the backlash system is active.

Note. The [backlash compensation mode](#) presumes no axis position correction, providing the user with just the choice of the direction from where the stage should approach the destination point, sticking to this selected direction.

The backlash compensation adjustment using XILab software is described in [Settings of kinematics \(Stepper motor\)](#) section. Switching on and backlash compensation parameters detection commands are described in [Programming guide](#).

The minimum backlash is reached if the approach to the setpoint is performed with the same movement parameters, so the optimal values of the backlash parameters are: the play speed must be equal to the nominal speed, the backlash compensation distance must be such that the device could reach the nominal speed.

Backlash compensation distance can be calculated from formula:

$$S = \frac{U^2}{2} \left[\frac{1}{Ac} + \frac{1}{Dc} \right] + 0.2U$$

S - backlash compensation, Ac, Dc - acceleration and deceleration, U - nominal speed, 0.2 - even motion time.

4.2.6. Rotation reversal

It is a common agreement that the coordinate increase corresponds to movement to the right, whereas its decrease corresponds to movement to the left. The rotation is to be reversed either if this rule is not satisfied due to physical stage location, or if the stage is supplied with an anchor which is pointed so that it doesn't match coordinate increase.

The rotation reversal may be switched on in the Motor parameters block of [XiLab menu](#). Switching this feature on will change the current coordinate sign; thus, "left" and "right" terms will get interchanged. For example, the first movement during the [Home position calibration](#) will perform physically to the opposite direction, the [Left](#) and [Right](#) commands in [XiLab main window](#) will interchange, etc.



Warning. Reverse is a setting that affects the whole controller operation if changed. The previously used [XiLab scripts](#) or [your own controlling programs](#) will work differently.

Particularly, the [limit switches](#) are adjusted independently from the reverse. Thus, after switching this mode on or off, one must re-adjust them.

4.2.7. Recommendations for accurate rotation

The controller can automatically adjust itself for the required mode, in order to maintain either the speed or the coordinate. However, both the speed and the adjustment property depend on the controller settings. The stepper motor working in steps and microsteps positioning mode can instantly reach the required operating conditions. If the stepper motor is physically unable to provide the required speed or acceleration, the rotation will most likely stop completely. The movement will not fail if a feedback sensor such as quadrature encoder is used as a reference; however, the controller probably won't be able to maintain the required rotation parameters.

The additional position sensor (encoder) is required for DC motors. The indirect connection of controlling scheme affection with DC motor stage displacement results to slowing down of reaching the required coordinate or speed. The following recommendations will help you to accelerate this process and to make it more stable:

- The profile corresponding to the stage being used is normally uploaded to controller and is used by it. Please upload the profile from the [Configuration files](#) chapter if you aren't confident that it is proper;
- The motor doesn't enter the limitation mode for one of the operating parameters (refer to [Motor limiters](#) and [Power control](#) chapters). Such limitations are displayed by the horizontal bar above the [Current](#) indicator in either [Power](#), [Voltage](#) or [Speed](#) blocks in the [Motor](#) section of [XILab Main window in single-axis control mode](#). For more information please refer to [Motor limiters](#) and [Power control](#) chapters.
- There are no mechanical impediments for rotation, the axis and stage are not jammed;
- The output power of power supply unit being used is sufficient (see the [Safety instructions](#)).

4.2.8. PID-algorithm for DC engine control

Algorithm description

DC engine is controlled by the PID regulator, with the coordinate as the controlled parameter. The controlled coordinate changes according to motion settings and incoming commands to provide motion capability. We will call controller coordinate the running position. DC engine winding PWM signal fill factor is the control signal of the regulator.

The control action is calculated according to the following formula:

$$U(t) = I + P + D = K_P \cdot E(t) + K_I \int E(t) dt + K_D \frac{dE(t)}{dt}, \text{ where:}$$

$U(t)$ - is the control action

$E(t)$ - is difference between the running coordinate and the current motor coordinate

K_P, K_I, K_D - are proportional, integral and differential coefficients of the regulator. Regulator coefficients are set on [PID settings page](#) of the XILab program or programmatically by calling `set_pid_settings()` function of the `libximc` library (see [Programming guide](#)).

The resulting value is normalized according to the following formula to make PID regulator action independent of motor type, feedback sensor and working voltage:

$$DC(t) = \frac{U(t) \cdot U_{nom}}{U_{supp}(t) \cdot IPS}, \text{ where:}$$

$DC(t)$ - is the PWM fill factor

U_{nom} - is the nominal (maximum) motor voltage, (see [Motor limiters](#)).

$U_{supp}(t)$ - is the current supply voltage

IPS - is the feedback encoder resolution in counts per revolution

This approach allows to change motor type, feedback sensor and voltage supply unit without reconfiguring PID regulator.



Warning. Do not forget to change [PID regulator coefficients](#) according to abovementioned formula if you are going to change maximum motor voltage.

Particular properties of the algorithm

PID regulator coefficients

[User set values](#) are normalized to keep optimal PID regulator coefficients in [0..65535] range.

Let's consider the effects different components have for better understanding.

We will assume the supply voltage $U_{supp}(t)$ is constant and equal to the motor nominal voltage U_{nom} . With this assumption PWM fill factor will be equal to 1 in the following cases:

1. $K_P = 1, K_I = 0, K_D = 0$ - if target position is ahead of real position by 256 motor shaft revolutions
2. $K_P = 0, K_I = 1, K_D = 0$ - if integral in the formula above is equal to 52.5 revolutions · second
3. $K_P = 0, K_I = 0, K_D = 1$ - if real motor speed is higher than the required speed by 96000 rpm.

Reaching target position

Target position is considered to be reached when motor shaft reaches the target position. Some oscillations around target position are possible. Motor will need some time to stop and return to correct position if smooth deceleration is not used and an immediate stop command is received or an emergency stop by limit switch has happened.



Warning. Long time oscillations around the target position while the motion is considered finished are possible if the PID regulator is set up incorrectly.

PID regulator tuning recommendations

There are three quality criterions used when tuning PID regulator:

- Speed maintenance accuracy, defined as a mean deviation of current speed from desired speed. Speed maintenance is considered to work optimally if the speed takes no more than three distinct values when moving. It is impossible to achieve greater accuracy because speed values are quantized.
- Position reach quality, defined by the following criterions:

- Time until final stop in target position (lower is better).
- No slip on approach to the target position.
- No oscillations around target position before stopping.
- No spontaneous shifts from the target position after stopping.
- Low noise when moving. Noise level is increased when only one of the PID coefficients is increased.

One can choose individual criterion priority depending on the task at hand when tuning PID regulator.

1. It is recommended to disable all DC motor limits including smooth acceleration/deceleration when you start tuning PID regulator.
2. It is recommended to tune PID regulator to maintain constant speed first.
3. It is recommended to start tuning PID regulator with integral and differential coefficients set to zero.
4. Set proportional coefficient $K_P \leq 10$
5. Set required movement speed and start the movement far away from the limit switches.
6. Gradually increase K_P and observe current speed graph. Find optimal K_P which makes the controller maintain current speed the best and makes time to reach target speed less dependent on K_P . One should be aware of possible noise level increase.
7. It is recommended to tune K_I next. Integral PID regulator coefficient has more influence on position reaching behavior.
8. Set integral coefficient $K_I \leq 10$ and start movement to position. It is convenient to use "shift on offset" command for this.
9. It is advisable to use sufficiently long shifts so that motor reaches at least 20% of required speed.
10. Increase of K_I makes the controller stop at the target position faster.
11. Achieve faster reaching of the target position by gradually increasing K_I . One should stop increasing this coefficient when either quality of position reaching degrades substantially or noise levels increase. Slip at the target position will remain regardless.
12. Adjust K_P up or down to decrease oscillations at the target position.
13. After one adjusts K_P one should check the speed maintenance quality and noise levels. If these parameters are unsatisfactory then one should adjust coefficients towards their previous values.
14. After setting K_I and K_P you can set up K_D .
15. It is recommended to start tuning K_D in speed maintenance mode and then check other quality parameters.
16. One should increase K_D until speed oscillations around target speed stop decreasing.
17. In case of target position slip one should increase K_D . However, further increases of this coefficient will lead to oscillations around target position. One should keep a balance between oscillations and target position reaching speed.

Turn on smooth acceleration/deceleration if you plan on using this mode. This can lead to the slip at the target position. To compensate one should increase K_I .

After these steps the initial setup of PID algorithm is complete. The obtained coefficients are in most cases suitable for motor operation. To further optimize these coefficients one can vary them while continuously monitoring quality according to the relevance of chosen quality criterions to the particular task.

Note. It is not recommended to adjust more than one coefficient at a time while tuning the PID regulator.

IMPORTANT. It is extremely not recommended to start with large values of PID regulator coefficients or to rapidly adjust them. This can lead to self-excitation of speed oscillations and motor failure.

4.2.9. Stop motion modes

There are two stop motion modes in the controller:

- emergency stop;
- stop with deceleration.

Emergency stop

Emergency stop is initiated by the command *STOP*. The controller tries to instantly stop the rotation of the motor shaft. This can lead to missed steps in a stepper motor, if no feedback is used. Abrupt cessation of movement can adversely affect the equipment, for example, may shift samples on the microscope stage or require additional adjustment of the optical line after a sudden stop.



Warning. When the controller is configured to trigger a stop on the left/right *limit switch*, it always occurs immediately when the stage reaches the limit switch. This should be avoided.

Stop with deceleration

Stop with deceleration is initiated by the command *SSTP*. A smooth stop occurs with deceleration *Deceleration*, if it is not disabled in the *acceleration mode* settings.



Warning. If the *acceleration mode* is disabled, then there is no difference between the emergency stop and the stop with deceleration. An *SSTP* command will then result in an immediate stop.

4.3. Main features

1. Supported motor types
2. Motor limiters
3. Limit switches
4. Automatic Home position calibration
5. Operation with encoders
6. Revolution sensor
7. Steps loss detection
8. Power control
9. Critical parameters
10. Saving the parameters in the controller flash memory
11. User defined position units 8SMC5

4.3.1. Supported motor types

Currently the controller supports stepper and DC motor types. The parameters of supported motors are described in [Specifications](#) chapter.

Stepper motors

Rated current is the main parameter of the stepper motor. The rated current is adjustable at the [Settings of kinematics \(Stepper motor\)](#) section.

IMPORTANT. The motor will gradually overheat and get physically damaged if rated current is exceeded. Make sure that the rated current value is set according to the used stage. All the settings are proper in default stage profiles.

Step division mode is another important parameter. The following step division options are available to user:

- 1 (full) step
- 1/2 of the step
- 1/4 of the step
- 1/8 of the step
- 1/16 of the step
- 1/32 of the step
- 1/64 of the step
- 1/128 of the step
- 1/256 of the step

The microstep mode is set either on [Settings of kinematics \(Stepper motor\)](#) page or by motor adjustment commands. See the [Communication protocol specification](#) and the description of the related functions in the [Programming guide](#) chapter.

Note. The controller always uses the internal step division value equal to 1/256. If the user selects a coarser step division, the software will display only the multiple of the coarser step division positions and both adjustment and transmission are possible only in that coarser step division mode. This is done for compatibility with both obsolete and actual software operating with small multiples of the step division values. On the other hand, operations with the largest step division value provides the most smooth and silent rotation at the smaller speed values.

The number of steps per revolution is the another direct parameter of the stepper motor. This setting does not affect the rotation but is used in [slipping control](#) block or with motors with the [encoder](#) feedback.

Note. The controller supports stepper motors with feedback sensor - encoder. The [encoder](#) can be used as the main position sensor ([more info](#)) and as the slippage, backlash or steps loss detector ([more info](#)). Using the encoder facilitates a stable passage of the resonant speeds without movement disruption.

DC motors

Unlike stepper motors, controlling DC motors requires feedback. Currently only [encoder](#) is supported as a feedback sensor. Main DC motor parameters are maximum current and voltage, which can be set on [Settings of kinematics \(DC motor\)](#). Main [encoder](#) parameter is counts per revolution.

IMPORTANT. The motor will gradually overheat and get physically damaged if rated current is exceeded. Make sure that the rated current value is set according to the used stage. All the settings are proper in default stage profiles.

IMPORTANT. Setting wrong value of encoder counts per revolution will lead to the controller being unable to maintain speed correctly. In some cases it may lead to stage or reducing gear failure.

DC engine is controlled by the [PID regulator](#). Please carefully read [PID-algorithm for DC engine control](#) before you start working with it.

IMPORTANT. Wrong PID regulator settings might lead to stage failure. All supplied profiles are preset with correct PID settings. It is not recommended to alter these settings unless absolutely necessary.

Engine selection criteria

Pulse-width modulation (PWM) is a widely used way to control winding's current in different motor types. It leads to current oscillations at PWM switching frequency (so-called "current ripple"). Current ripple's amplitude depends on motor characteristics like its winding inductance and resistance. Motor can heat up more than it is expected with nominal current due to current ripple, i.e. $\frac{P_{real}}{RI_s^2} > 1$. There is RI_s^2 - power dissipated by I_s (stabilization current), P_{real} - real power, dissipated in motor. For overheating estimation we recommend to use this graph:

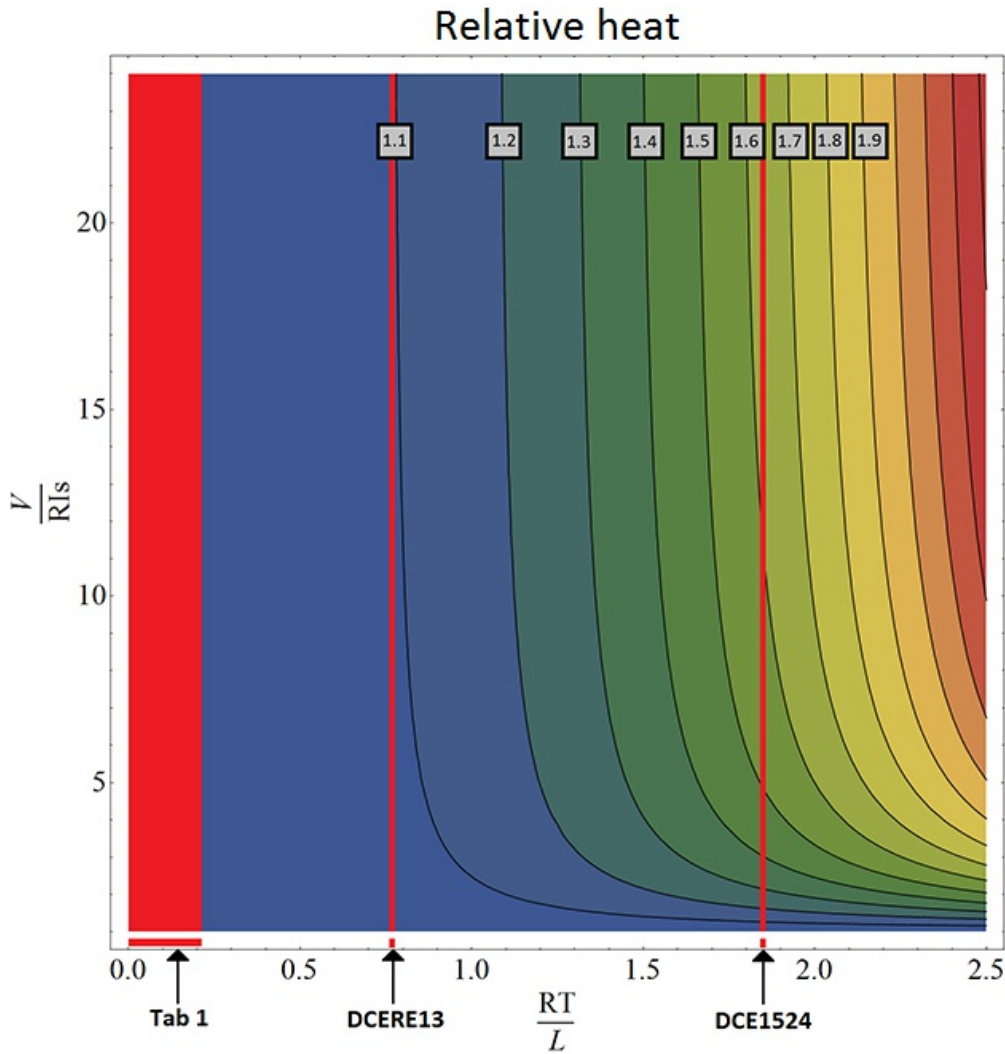

Tab 1

Мотор	RT/L
20	0.19576
28	0.07253
28s	0.07168
4118L1804R	0.02715
4118S1404R	0.02844
4247	0.0273
D42.3	0.0223
5618	0.0146
5618R	0.0146
5918	0.0116
5918B	0.012
VSS42	0.029
VSS43	0.0256
ZSS	0.04248
DCERE25	0.2106

The motor's overheat is determined by this sequence:

- $\frac{RT}{L}$ calculation. There is R, L - resistance and inductance of motor winding (refer to the motor documentation). T - PWM period time. It's value should be 51.2 us for stepper motors and 25.6 us for DC motors.
- $\frac{V}{RI_s}$ calculation. This parameter shows power voltage excess under nominal voltage. There is V - power voltage, R - winding resistance, I_s - stabilization current.
- Overheat definition. After first two steps point can be plotted at the graph. Now we should define the region, which corresponds to overheat degree. For example, the region between 1.1 and 1.2 corresponds overheat value between $1.1 * RI_s^2$ and $1.2 * RI_s^2$

There is DCE1524 overheat calculation example:

$$T = 25.6 \text{ us} \quad R = 5.1 \text{ Ohm} \quad L = 70 \text{ uH}$$

$$\frac{RT}{L} = 1.86$$

Now we can draw vertical line corresponds this value (look at graph) and find out overheat with different power voltages. Let's assume $I_s = 500 \text{ mA}$. Nominal voltage in this case is $R * I_s = 2.55 \text{ V}$. If power voltage exceeds nominal more than 5 times but less than 10 times DCE1524's overheat will be between 1.5 and 1.6. Motor overheats about 1.65 times with 30 V of power voltage.

All the major engines and their parameters have been marked in Tab. 1.

4.3.2. Motor limiters

Motor winding current and voltage limiters and motor shaft revolution speed limiters are provided to ensure safe operation. These limiters, if activated, will lead to gradual power and rotation speed decrease until the parameters being limited are within acceptable range. Motor limiters work with voltage and current values directly on motor windings, unlike [critical parameters](#), which work with current and voltage at the controller input. Another distinctive feature of limiters is that they do not stop the motor and let the controller enter **Alarm** state; they merely limit voltage, current and motor revolution speed.

For DC motors:

- [Max voltage](#) is the nominal motor voltage. It defines maximum motor winding voltage. It is usually used to limit voltage growth when the motor or stage is jammed. [Should only be used if maximum motor winding current is unknown.](#) This parameter is used in [PID regulator](#).
- [Max current](#) defines maximum engine winding current. It is usually used to limit current growth when the stage is jammed. One should set this limit based on maximum current which can be sustained by the motor without damage (primarily by heating).
- [Max RPM](#) is the maximum motor shaft revolution speed. Is usually used to limit revolution speed when working with reducing gears and other devices which have strict maximum speed limits.

Note. One should be aware of the distinction between maximum motor current and nominal current. In general they may be different because of motor cooling features and operating conditions. Also, one should not mix up maximum current and starting current with stationary motor shaft.

IMPORTANT. Changing maximum motor voltage might disrupt PID regulator. For more information see [PID-algorithm for DC engine control](#).

IMPORTANT. Maximum motor voltage may exceed nominal voltage, usually by 10-15%. If you are using a motor with low load and you need high motor speed, then you can increase maximum motor voltage.

Current limiter operation.

It is important to note that maximum current limiter does not react immediately when working with DC motors. When a higher than maximum current is detected in the motor winding, voltage supplied to the motor is gradually decreased until winding current is less than [Max current](#). In the worst case of a rapid jam during high-speed movement motor voltage may decrease for at most 370ms. If the current limit is chosen right, motor should not overheat during this time.

Note. If the [Max current](#) value is set too low, it is possible that DC motor will not be able to move under high load or high friction.

For stepper motors:

- [Max\(nominal\) Speed](#) is a maximum motor shaft rotation speed in steps per second. Current stepper motor speed is defined by [Speed](#) parameter (see [Predefined speed rotation mode](#)).
- [Nominal current](#) defines maximum motor winding current. This value cannot be exceeded due to characteristic stepper motor control.

In the XILab software limiter settings are described in sections [Settings of kinematics \(DC motor\)](#) and [Settings of kinematics \(Stepper motor\)](#).

4.3.3. Limit switches

Limit switches designation

Limit switches are designed in order either to prevent the stage movement out of permissible physical movement range or to limit its movement range according to user-defined requirements. Incorrect setting of the limit switches may result to stage jam if the controller goes beyond the permissible range.

General settings

If the limit switch is active, a corresponding flag is placed in the state structure and the appropriate icon (left or right) is displayed in [XILab Main window](#). The controller can either stop any movement in the direction of any active limit switch (left or right) or stop the movement to the single limit witch (left or right) or not to limit the movement. Limit switches settings are performed in XILab software (see the [Motion range and limit switches](#) section).

Programmable motion range limitation

If there are no hardware limit switches for the motion range but the stage requires such limitation, the programmable limiters can be used. For doing that, the limiters should be switched to limitation mode according to position reading (see the [Motion range and limit switches](#) section). The left and right margin fields are used (the right margin value should be higher than the left one). In this mode, the left limit switch is active if the actual position is less than the left margin value and the right one is active if the actual position is greater than the right margin value. The operation time is about one millisecond.

Warning. The programmable motion range limitation is reliable only if there is no direct setting of the new position by ZERO or SPOS commands, or if there is no steps loss or encoder malfunction if it is used for positioning, or if there is no frequent power-cut during the rotation. If any of these problems appears, the programmable range should be re-adjusted. The appropriate reference sensor allows the automatic re-adjustment using the [automatic Home position calibration](#) feature.

Hardware limit switches

The controller may operate with limit switches based either on dry contacts, or on optocouplers, or on reed switches, or on any other sensor types generating a 5V TTL-standard "logic one" electric signal in one state and a "logic zero" in the other. Each limit witch may be configured independently. There is also possible to change the position of limit switches or their polarity in software.

Note. Limit switches are also useful for [automatic Zero position calibration](#).

Limit switches connecting instructions

Limit switches should be connected to [D-SUB connector](#) pins as it is shown at the diagrams:

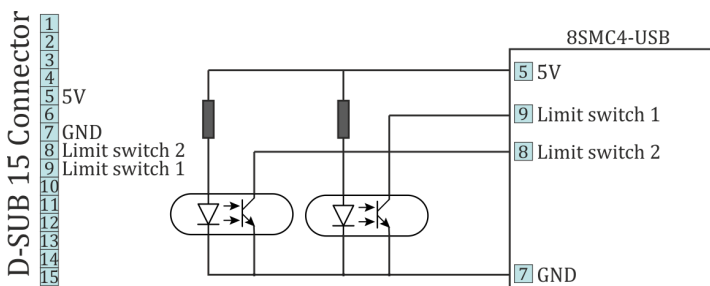

The "optocoupler" limit switches connection diagram.

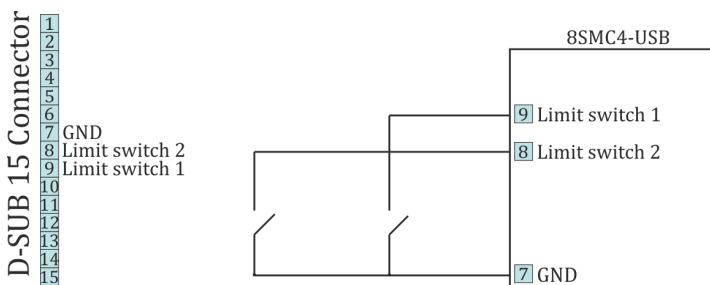

The "dry contact" limit switches connection diagram.

Limit switches location on translators

The settings of which limit is left or right is required by the controller. Sometimes it is unknown a priori, just it is clear that both limit switches are connected and fire if the corresponding limit of the motion range is reached. The stage jam is possible if the limit switches are configured improperly. Therefore, the controller supports just a simple detection of incorrectly configured limit switches, shutting down the movement on both of them. Please make sure that their polarity is configured correctly and the shutdown mode is activated on both of limit switches. The flag of improper limit switch connection detection should be turned on in corresponding [XiLab software menu](#). Start the movement to any direction until the limit switch shuts the movement down. If there was right-side movement but the left limit switch became active, or vice versa, the limit switches should be interchanged (see the [Motion range and limit switches](#) chapter). If the improper actuation of the limit switch is detected and if the corresponding feature is set in the [Critical parameters](#) menu, the controller can turn the Alarm mode on.



Warning. The protection against mistaken limit switches connection doesn't guarantee the complete solution of the problem, it only makes the initial configuration procedure easier. Particularly, don't start the movement if any of the limit switches is active, even if the protection is on.

4.3.4. Automatic Home position calibration

This feature is used for detection and placing the movement to the starting position. This option of the controller is designed for simple search of "Home", or "Zero" position by user himself, with no need of any programming skills. The Home position is set relative to one or two external sensors and/or to an external signal.

Automatic Home position calibration feature is configured by user in *Device configuration->Home position* folder of XILab software (see the [Home position settings](#) chapter) and is activated by the button in [XILab main window](#).

After this feature is activated, the controller rotates the motor to the defined direction with normal speed to quickly locate the stop position. After finding the boundary position controller assigns motor back half a turn and begins rotate the motor to the defined direction, but with another calibration speed. The calibration speed is usually set lower than the normal rotation speed in order to improve the calibration accuracy. There are three ways to determine the completion of the motion, according to user-defined preferences:

- **rotation until the limit switch is reached**, the actual configuration of limit switches is used (e.g., polarity, location). For more details please refer to [Motion range and limit switches](#) chapter.
- **rotation until a signal from the synchronization input is received**, the actual configuration of synchronization input is used. For more details please refer to [Synchronization settings](#) chapter. If the synchronization input is switched off by program, the signal from it will never be processed.
- **rotation until a signal from the revolution sensor is received**, the actual configuration of revolution sensor is used. For more details please refer to [Position control](#) chapter.

Successful completion of home position calibration results in assertion of the STATE_IS_HOMED flag in the [controller state structure](#). If after this position somehow got lost (stop on [limit switch](#), [emergency stop](#) while moving, [steps loss detection](#), turns the [Alarm mode](#)), the corresponding flag is dropped and it is necessary to re-calibrate the home position.

Note. If command [emergency stop](#) or command [power shutdown](#) are executed while the engine is stopped then it isn't necessary to re-calibrate the home position and the STATE_IS_HOMED flag is not dropped.

Note. If the completion of the motion should happen at the limit switch, the calibration program is not crashed.

Fine calibration

After the first displacement the controller position is defined. However, some additional rotation may probably get turned on before the movement to Home position is performed. It provides fine Home position calibration that may reach 1/256 of the step for stages with stepper motors or 1 encoder count for stages with DC motors. If the corresponding flag is switched on, the controller rotates the motor to user-defined direction with defined rotation speed until a signal either from the [synchronization input](#) or from the [revolution sensor](#) is received or until the [limit switch](#) is reached, according to user-defined preferences. Using the signal from the sensor on the shaft from motor to reducer and performing the motion with the small speed does make sense. It provides the maximum accuracy. Since first and second movement signals might happen simultaneously a flag is provided, which will start tracking second motion end signal only after motor shaft half-turn. This allows avoiding the signals of the completion of the first and second motions to be in ambiguous sequence. As a result of optional second motion, the calibrating position becomes more accurate.

Note. If the second phase of the motion is used, the first motion usually can be performed at the high speed since it provides just a coarse calibration and the accuracy is not required there. The accuracy will not improve if the second limit switch is used for the second phase of the motion since its physical characteristics are the same as for the first limit switch.

Finally the controller moves the motor to the defined direction with the defined speed at the defined [Standoff](#) distance. This is what required to reach the Home position.

Note. The position reached as a result of calibration will slightly depend on the speed of the last motion until the selected sensor responded. Therefore, don't change the speed parameters for further successful reaching the same position.

The automatic Home position calibration **features are described** in the [Programming guide](#) chapter.

The parameters configuration commands are described in the [Communication protocol specification](#) chapter

The position calibration command is described in the [Communication protocol specification](#) chapter.

A [set_zero script](#) is supplied with XILab software pack, providing the automatic Home position configuration. This script changes the Standoff setting in Home position folder, making the actual position as the Home one.

How to use the script:

- place the movement to the desired position
- launch the script and wait until it's finished.

As a result, the movement will be in the same position and all the following calls of homing function will move it there. Make sure to [save the settings](#) to controller's nonvolatile memory.

4.3.5. Operation with encoders

Application of encoders

Encoders are designed for creation of accurate and fast feedback according to the coordinate for all the electric motor types. The feedback is performed by the motor shaft position, by stage's linear position, by the motorized table rotation angle or by any other parameter related to the shaft position and measured by using the two-channel quadrature encoder complying the requirements described in [Specifications](#) chapter for the appropriate controller type. Controller **8SMC5** supports differential encoders and simple (single-ended) encoders, with opportunity auto-detect the type of encoder. Controller **8SMC4** supports only single-ended encoders.



Warning. Auto-detect works only with 3.3V and 5V (with error 0.2V) encoders

What is quadrature encoder?

Encoder is a mechanical motion sensor. The quadrature encoder is designed for direct detection of the shaft position. The sensor transmits the relative shaft position by using two electric signals at CH A and CH B channels shifted relative to each other at 1/4 of period.



The signals at CH A and CH B outputs of quadrature encoder.

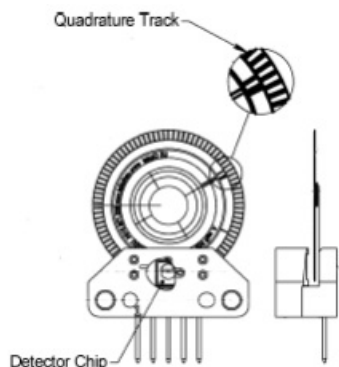

An optical quadrature encoder mechanics.

An optical quadrature encoder mechanics is shown at the figure above. There are two optocouplers used. The operational principle of an optocoupler is as following: a LED and a detector are arranged opposite to each other from different sides of a disc. The optocoupler opens when disc's "window" coincides with the detector (the outgoing signal is logic zero). The outgoing signal is logic one if the detector is closed by opaque part of the disc.

Number of steps per revolution (CPR) is the main parameter of the quadrature encoder. The standard resolution values for encoder are from 24 to 1024 CPR. Each period of signal alteration is interpreted by 1, 2 or 4 codes which is corresponding to X1, X2 and X4 operating modes. This controller uses the most accurate X4 mode. The maximum frequency of each encoder's signal depends on the applied encoder itself, since for 200 kHz in X4 mode the controller can read up to 800,000 encoder counts per second.

Controller's features

There are two operating modes with encoder available for the controller:

- the encoder is used as the main position sensor (this is the main operating mode for DC motors; the closed loop for stepper motors is available since firmware versions [3.10.x](#)).
- slippage, backlash or steps loss detection (the recommended mode for joint operations with stepper motors, in case the encoder is not used as a primary position sensor, see [more](#)).

Driving encoder mode

This is the mode when all parameters of the engine including position and velocity are measured directly by the encoder and are denominated basing on counts of encoder. The position is displayed directly in the encoder counts, the speed is denominated in RPM (revolutions per minute). The speed is calculated by the controller basing on the speed alteration data as well as on the number of encoder pulses per one complete revolution of the motor shaft that are displayed in feedback configuration block at the Settings of kinematics ([Stepper motor](#)), ([DC motor](#)) folder. Note that in the case of DC motor the [speed maintaining mode](#), the [mode of movement to the predefined point](#) as well as all their derivations use PID control algorithms and the [appropriate settings](#) are required. The driving encoder mode optimizes stepper motor control, this leads to noise reducing and facilitates a stable passage of the resonant speeds with no risk of steps loss when the coordinate flounders and the recurrent [calibration](#) is required.

New! New motor control algorithm is included in the latest firmware. The algorithm add encoder close-loop feedback suppressing motor oscillations and acoustic noises. It makes almost all motors several times faster without any step loss. It all comes with a free update of firmware and software. The new algorithm is available with firmware 3.9.16+ which can we downloaded from our [Software](#) page or updated through XiLab. Use XiLab 1.13.13+ and set Feedback to Encoder on the Device configuration -> [Stepper motor page](#). Note, that position is in encoder counts now.

Encoder connection

The encoder is connected to the controller via **D-SUB 15 pin** connector, which is in all systems ([controller board](#), [one-axis](#) and [two-axis](#) in box and [multi-axis](#))

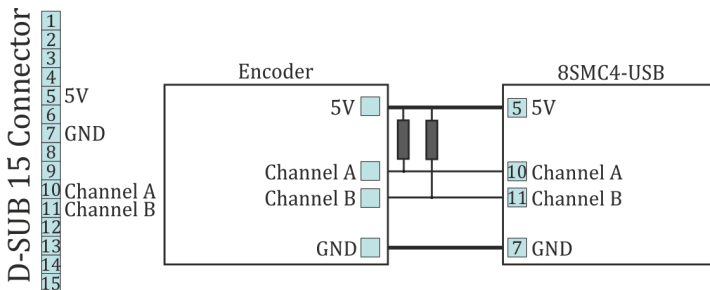

The diagram of single-ended encoder connection using D-SUB 15 pin connector.

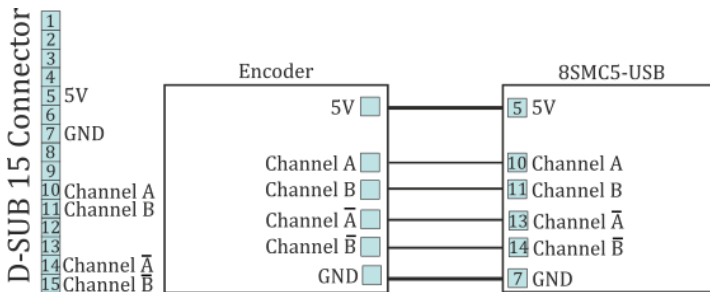

The diagram of differential encoder connection using D-SUB 15 pin connector.

See also the [Example of a motor connection](#) chapter.

Warning. Encoder inputs of the controller internally pulled up to logic one by using the 5.1kΩ resistors. Frequently encoder outputs are of "open collector" type equipped with internal pull-up resistor. During the data transmission they provide good characteristics while passing from higher logic level to lower. However, the pass from logic 0 to logic 1 is more graduate. It passes through the RC circuit formed by pull-up resistor and cable capacitance. This is the most important thing if the cable is long. If the internal pull-up is not sufficient, the pull-up resistor with $r=1.5k\Omega$ may be added for every +5V to each output in order to improve the transmission speed parameters; before doing that please check if the open collector of the encoder can transmit 5mA current. The resistors insertion diagram is shown above. The maximum operating speed for quadrature encoder may be increased by adding a push-pull driver with the outgoing current over 10mA to its output, providing quick 0 - 1 and 1 - 0 transmission edges.

4.3.6. Revolution sensor

Revolution sensor is designed for [stepper motor shutdown \(failure\) detection](#) and for better accuracy of Home position calibration procedure (see [Automatic Home position calibration](#)).

The controller may receive the actual position data from the external revolution sensor mounted on the stepper motor shaft. The sensor transmits its signals to the controller once or many times per one revolution of the motor.

Usually the revolution sensor is a small disc with precise graduation scale mounted on the motor shaft. A light source (LED) and a sensor of the optocoupler are placed at the opposite sides of the disc. The sensor is open if there is no interrupter between the LED and the sensor (the logic zero is transmitted to optocoupler's output), whereas the logic one is transmitted if the light source is closed by the interrupter.

By default, the lower logic level is interpreted by the controller as the active mode of the revolution sensor. The controller's input is pulled to logic one level, thus, the disconnected revolution sensor means its inactive mode. The controller's input can be inverted if necessary, in that case the logic one level will mean the active mode.

Connection diagram

The revolution sensor should be connected to the controller via [15pin D-SUB connector](#), which is in all systems ([controller board](#), [one-axis](#) and [two-axis](#) in box and [multi-axis](#)).

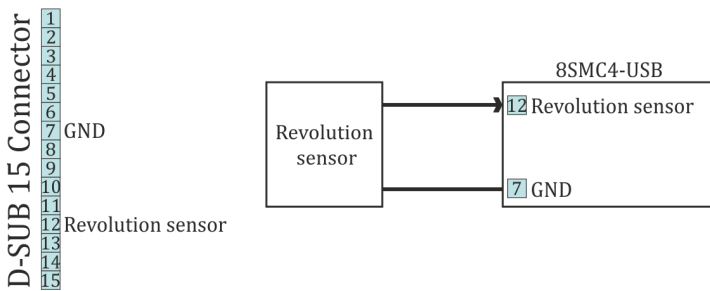

Scheme of revolution sensor connection to the 8SMC4-USB based system

4.3.7. Steps loss detection

This mode is generally used while operating the stepper motor at full speed or limit loads when the shaft jam resulting to the steps loss is possible. In this case an additional position sensor ([revolution sensor](#)) or [encoder](#) allows tracking this moment, informing the user about it. This feature should be applied **with stepper motors only** and it allows detection of the steps loss. Steps and microsteps are the measurement units for all coordinates and shaft positions.

When the encoder is used, the controller stores both number of steps and number of encoder's counts per revolution (see the [Settings of kinematics](#) folder of XiLab program). When the feature is activated, the controller saves the current position in steps of the motor and the current position according to the encoder data. Then, during the motion, the position data according to the encoder converts to steps and if the difference exceeds the predefined value then the slippage is indicated and the [Alarm mode](#) turns on (if the related option is active). For more information regarding use of encoder as the steps loss detector please refer to [Operation with encoders](#) chapter.

If the revolution sensor is used, the position is controlled according to it. The controller stores the current position in steps according to active and inactive edges at the sensor's input. Then, at every revolution (number of steps per one full revolution is set by *Steps per turn* parameter, see the [Settings of kinematics \(Stepper motor\)](#) chapter) the controller checks if the shaft has been displaced and how many steps for. If the mismatch exceeds the predefined *Threshold* value (which is defined in position control settings, see the [Position control](#) chapter), the slippage is indicated by the state structure flag. If the appropriate flag is set and if the error is detected, the controller turns the [Alarm mode](#) on and the motor shuts down, otherwise the motion is continued. If the slippage indication flag is active, the controller turns the [Alarm mode](#) on when the appropriate parameter in the settings is active.

Also you can enable the position correction option in the [position control settings](#). If this option is enabled and the steps loss is detected the controller stops the movement, adjust the step position on the basis of the encoder data and try to start the movement again. The flag of the control position error [The position control error flag](#) is set when the desynchronization of the steps and the encoder position is detected and it will be unset automatically when the position becomes corrected. If the controller is not able to eliminate the desynchronization the controller is set [the position control error flag](#) and goes to [the Alarm mode](#). If the steps loss happens during the movement [the movement command status](#) will not be changed while the position is correcting. If the steps loss happens during holding a position [the move to position](#) command will be executed for return the motor axis to the holding position.

Note. For using the position correction function you should have the encoder with the resolution at least two counts per the motor step.

Note. For correct operation of the position correction option you should let the controller to hold the position during 1 second for calibration before moving. It necessary to repeat the calibration after the transition to [the Alarm mode](#) or after changing the settings.

Note. If the automatically position correction is used it is not recommend to set the *Threshold* value above than 3 steps because in this case not any slippage will be corrected.

Note. *The soft stop* and *the hard stop* commands could be ignored by the controller if it was sent during position correction process. In this case you can send *the soft stop* command twice for power off the motor windings.

Note. If you use [the software limit switches](#) it is not recommend to use the automatic position correction because the limit switches positions will be changed during position correction process.

Note. A hard STOP launches the the re-calibration process of the revolution sensor position, and the calibration starts after the revolution sensor activates during the motion controlled by the motor. It means that the slippage won't be detected if the shaft has been rotated manually right after the hard stop since the calibration hasn't been performed yet.

Note. If the motor revolution sensor is bouncing (mechanically), the misoperations of the revolution sensor are possible at the very low speeds.

Note. The position control of the revolution sensor can't detect the shaft rotation at the zero speed, i.e., if the motor is shut down and the shaft is rotated manually, it won't be detected.

4.3.8. Power control

Current consumption reduction

Controller has an option to set current when idle to reduce power consumption. This mode is active by default. It is widely used to lower stepper motor heating in hold mode while keeping position maintenance accuracy. Hold current is set as a percentage of nominal winding current. A time delay after which current will be reduced is also defined. Current reduction mode can be disabled. To set current reduction see [set_power_settings](#) function in [Programming guide](#) or XILab [Power consumption settings](#) page. Nominal engine current is set by [set_engine_settings](#) function (see [Programming guide](#)) or on [Settings of kinematics \(Stepper motor\)](#) page in XILab.

A reasonable hold current level is 40-70%. This will lower power consumption 2-4 times, while keeping holding force sufficient. A reasonable time to reduce power lies in 50-500 ms range. This is a sufficient time for mechanical oscillations, which might knock the system out of the hold position, to subside.

The motor power shutdown

There is also a power shutdown mode to reduce power consumption of a stepper motor. It is mostly used to stop wasting power on position hold, when no movements are performed for a long time. This mode is on by default, but can be disabled by the user. Time from motor stop to power off is set in seconds. A reasonable time is 3600 seconds (one hour). To set power off options see [set_power_settings](#) function in [Programming guide](#) or XILab [Power consumption settings](#) settings page.

Time delay calculation specifics

All timeouts work in the following way: on each transition to stop state time is saved with millisecond accuracy. After certain set time is elapsed depending on PowerOff/CurrentReduce enabled state a motor will reduce winding current or turn its power off. All settings can be changed online. For example, if you increase PowerOff timeout value after the poweroff has already happened then windings will get powered on and a PowerOff function will activate after the new delay. Timeout countdowns cancel after each movement start.

Jerk free function

Sometimes smooth motor winding current changes are required to reduce vibrations of a mechanical system. That's why a [Jerk free](#) option is provided, which allows one to set current ramp-up time from zero to nominal value with millisecond precision. When this option is turned on all changes to stabilization current or winding powerdown will happen with smooth current increase or decrease. For example, if jerk free time is set to 100ms and the controller needs to reduce current to 50% it will be reduced over the time of 50ms (because 100ms are required to reduce current from full to zero). To setup Jerk free see [set_power_settings](#) function in [Programming guide](#) or XILab [Settings of kinematics \(Stepper motor\)](#) page.

Smooth current change function activates on any change in the amplitude of the winding current, for example on nominal hold current change. In this case current change speed is calculated based both on older and newer hold currents, whichever is higher. If controller needs to turn off the motor windings then current is gradually ramped down, then power output circuits are disconnected. If controller needs to power up the windings, then they are powered with zero current which increases up to nominal current.

There are exceptions to the rule, when the current is immediately reduced to zero even if Jerk free option is active. These are the critical errors/Alarm state (see [Critical parameters](#)) and controller reset events on firmware update. These events are rare and should not happen during normal stage operation.

A reasonable Jerk free time is 50-200ms, which merely leads to low-energy mechanical oscillations on 3-10 Hz frequencies which are significantly lower than noise from other common sources. Higher Jerk free times will lead to constant delays when current is switched on or off.

4.3.9. Critical parameters

Minimum and maximum values of currents, voltages and temperatures are used for safe controller operation. Any value out of acceptable range leads to the motion stop, windings power-down and Alarm state for the controller. Exiting the Alarm state is possible only after the critical parameter returns to normal and the STOP command is sent to the controller. Critical settings are used for all motor types.

The following parameters are available:

- Low voltage off defines the minimum voltage value of the controller power supply (measured in tens of mVs). The Low voltage protection flag is used to turn this option on, otherwise the minimum unpowering threshold doesn't work. The 6000mV to 8000mV range is sensible for operating power range of 12V to 36V. This type of protection helps to determine the power-cut moment due to activation of any sort of power supply unit protection. This may occur if the operating power consumption of the stabilized power supply unit is exceeded.
- Max current (power) defines the maximum current of the controller power supply (measured in mAs). The sensible value is twice the maximum operating consumed current registered during the tests. Use the [XiLab charts](#) for registration of the consumed current.
- Max voltage (power) defines the maximum voltage value of the controller power supply (measured in tens of mVs). The sensible value is 20% higher than power supply unit voltage.
- Max current (usb) defines the maximum current of the controller power supply via the USB cable (measured in mAs). The controller demands the current received via USB interface for its own needs (150mA) and for supplying the power to the devices connected to the [motor's connector](#) (200mA). This limitation is sensible within the range of 250mA to 450mA, depending on external devices powered by the controller. The USB interface is not designed for the current of over 500mA, although it is often able to stand the 1000mA to 1500mA current.
- Max voltage (usb) defines the maximum voltage value of the controller power supply via the USB cable (measured in tens of mVs). The controller may get damaged if the USB power supply voltage exceeds 5.5V value. Thus, 5.2V is the sensible limitation.
- Min voltage (usb) defines the minimum voltage value of the controller power supply via the USB cable (measured in tens of mVs). The controller doesn't work if the power voltage supplied via the USB interface is less than 3.6V. The voltage is measured at the controller input.
Low-quality USB cables may have different voltages on its ends in the presence of current. At least 4.0V voltage is required if the consumed current is high. The sensible value of the minimum voltage limit is 3.8V.
- Temperature defines the maximum temperature of the microprocessor (measured in tenths of degrees Celsius). The microprocessor can operate at the working temperature of up to 75°C and doesn't overheat by itself. Rise of its temperature indirectly indicates the overheating of the power part of the board. The overheating threshold range from 40°C to 75°C is sensible.

Flags:

- ALARM ON DRIVER OVERHEATING means entering the Alarm mode if the driver's critical temperature (over 125°C) is exceeded. The power driver indicates if its temperature is approaching the critical value. If the driver is still working then the further heating will automatically shut it down. It is recommended to set this flag and not to rely on automatic forced shutdown.
- H BRIDGE ALERT means turning the Alarm mode on if any fault of the power driver due to board overheating or damage is detected. This flag should be set on.
- ALARM ON BORDERS SWAP MISSET means turning the Alarm mode on if the triggering of the wrong limit switch, not corresponding to direction, is detected (see the [Limit switches](#) chapter). This flag is intended for clear indication of the response of the limit switch swap detection subsystem. The flag is recommended to be set on.
- ALARM FLAGS STICKING flag activates the sticking of the error indicators in the status structure of the controller, otherwise indicators are active only during the accident that caused the error. If there was a short-time error and its cause was independently removed, then sometimes the reason of Alarm remains uncertain. In that case the sticking is useful and the accident cause can get diagnosed in XiLab main window.
- USB BREAK RECONNECT - This flag configures the operation of an USB break reconnect block. When set, this unit starts to operate and monitor the loss of communication over the USB bus (for example, in case of a static discharge).

Configuration of parameters is described in [Critical board ratings](#) menu of XiLab software. The maximum available value configuration commands are described in [Programming guide](#).

4.3.10. Saving the parameters in the controller flash memory

The controller provides an option to save all its parameters into the non-volatile memory. The configuration is restored when the controller is powered on, after that the controller itself is instantly ready for operation. The stage requires no new adjustment every time the power is on. The controller stores its user-defined name which is useful for its further identification.

The non-volatile memory stores all the actual operating parameters of the controller related to [Device configuration](#) section of XiLab settings menu. Either **Save to flash** button of XiLab program or [command_save_settings](#) function are used for it (see the [Programming guide](#) chapter).

All the configuration parameters can get restored to controller's RAM from the non-volatile memory, not only when the power is turned on but also by clicking the **Restore from flash** button of XiLab program which provides the access to the data saved in the flash memory. Internally it uses [command_read_settings](#) function (see the [Programming guide](#) chapter). The restored settings become active instantly and all the modules of the controller get re-initialized.

4.3.11. User defined position units

Controller position is set and read in stepper motor steps or encoder counts, if encoder is available and enabled. Is it convenient to set position in mm (in case of translation stages), in degrees (in case of rotator stages) or in any other natural units. Controller software can translate coordinates to user-defined units: user can set a ratio, where a certain amount of controller steps is equal to the certain amount of user-defined units. This enables one to issue movement commands and read controller position in these user units. It applies both to XiLab interface and to usage in custom programs or scripts. Speed and acceleration are also set in units derived from user-defined ones (for example mm/s). [Zero position adjustment](#) can be done the same way in user-defined units as in encoder counts or step motor steps.

You can enable user-defined units in [XiLab](#) on page [User units settings](#). You can define the name of the natural units in XiLab.

Libximc library functions operating in user defined units have a `_calb` suffix. They take calibration structure `calibration_t` as an additional input. For more information see [Programming guide](#).

4.4. Safe operation

Several controller settings are directly connected with safe operation. If these settings are set wrong it may lead to controller or stage damage. Positioning element can be damaged by exceeded power, rotation speed, or by moving outside the allowed movement range. Usually it is enough to load a preset profile for your stage for safe operation, where all necessary settings are already made.

Movement range bounds and limit switches

Linear stages have limited movement range, unlike circular rotators. Moving outside of the allowed physical movement range is the main reason for stage jamming and damage. To prevent such kinds of breakages the movement range of stages is limited according to user requirements. For this reason [Limit switches](#) are used, but in some cases when, for example, when stage is not equipped with limit switches or has only one limit switch, movement range can be defined in software (see [Limit switches](#)). Frequently [limit switches](#) are reversed. In this case use the mechanism of reversed limit switches detection which is described in [Limit switches](#) section because otherwise the first motion to the border will lead to stage jamming. [Motion range and limit switches](#) is described in corresponding section. Settings commands are described in [Programming guide](#).

Movement range limiters

Nominal winding current is the main safety setting in stepper motors. This is the main parameter which defines power delivered to the motor. The nominal current should not exceed maximum allowable current for given motor. For more detailed information see [Motor limiters](#). For DC engines nominal current is a limiting parameter and should be set according to the maximum permissible current through DC engine. If maximum current is not known, then maximal voltage delivered to the engine may be limited. This also will prevent engine overheat although voltage limiting is a more coarse mode than current limiting. For more detailed information see chapter [Motor limiters](#).

Exceeding the speed limit might damage the stage or lead to faster wearout. It is necessary to set speed limit flag and to set correct maximum speed for the given stage. For more detailed information see chapter [Motor limiters](#).

Critical Parameters

Controller tracks voltages and currents which appear in its circuits and can react on their suspicious values. This reaction blocks the engine and prevents any further movement until the source of the problem is eliminated. Due to this it is possible to track winding-winding or winding-ground shortcuts which may happen because of stage cable damage or damage of the stage itself. This reaction also has informational character because it allows to track incorrect values of source voltage or oncoming overheating. That's why you should read [Critical Parameters](#) chapter and set necessary protection. In case of dangerous situation controller will enter Alarm state and the [main window of Xilab program](#) will be colored in red. If this happens, track and eliminate the source of danger before you turn off the Alarm. If you are using your own application for engine control you should pay close attention to Alarm status flag (see [Controller status](#)).

Operation with Encoder

If during encoder connection sensor channels are swapped, then during engine motion encoder will show direction in reverse. During operation with DC engine this situation will appear if engine control channels (DC+ и DC-) are mixed up. To fix these errors just set [Encoder Reverse](#) flag in Feedback section on [Settings of kinematics \(stepper motor\)](#) page for stepper motors and on [Settings of kinematics \(DC motor\)](#) page for DC motors.

It is also possible that there is no contact with one of encoder channels. In this case during motor motion values of sensor will be oscillating in [-1..1] range around the starting position.

During DC engine operation both of these errors will lead to malfunction in control algorithm, which is described in [PID-algorithm for DC engine control](#). If you have connected new DC engine for the first time it is strongly recommended to check encoder connection before starting the operation. To do this you should set corresponding regulation factor values $K_P=1, K_I=0, K_D=0$ and try to make motion to the right or to the left at a low speed. After the motion please check if encoder values are changing in correspondence with chosen directions. Set [Encoder Reverse](#) flag if it is needed.

4.5. Additional features

1. Operating modes indication 8SMC5
2. Operations with magnetic brake
3. Joystick control
4. Left-Right buttons control
5. TTL synchronization
6. Design of multi-axis system
7. General purpose digital input-output
8. General purpose analog input
9. External driver control interface
10. Serial port
11. Saving the position in controller's FRAM memory
12. The Standa stages detection

4.5.1. Operating modes indication

Controller status

Mode indication is provided in controller. For this purpose one dual-color LED is located on the board.

Green Power indicator shows presence of 3.3 V power supply of controller.

Red Status indicator represents controller operating mode.

Simultaneous glowing of both lights looks like **yellow glow**.

Flicker frequency Hz	Description
Lights don't glow	the device is shut down, there is no power supply
LED is green	the device is broken or the microprogram is not loaded
LED is yellow	the device is in Alarm
0,25	the device is operating but there is no connection with USB from PC
1	the device is operating, the movement is stopped
4	the device is operating, with movement
8	the device is in re-flashing mode
10	the device is in USB bus reconnecting mode

Power/Status indicator operation modes

Indication of limit switches

Multifunctional 20 pin BPC connector is provided with limit switches activity indication. High logic level appears on the corresponding output in the moment of limit switch activity. Active state is determined from limits switches settings (see [Motion range and limit switches](#))

Connection diagram

Note. In case of additional LEDs they should be designed for 4 mA operational current. There is no need in additional current limiting resistors. Operational current for typical LEDs is about 2 mA. It is not recommended to use blue and violet LEDs because of their high cut off voltage and as a consequence low brightness.

Controller board

Indicators Power and Status are duplicated by outputs on the multi functional 20 pin [BPC connector](#) with the next scheme of LEDs connection:

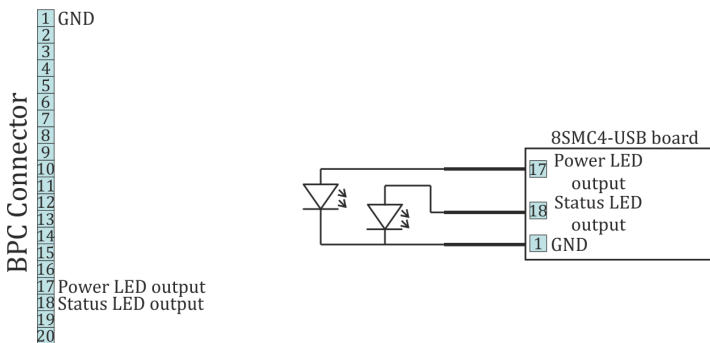

Connection of Power и Status indicators to the controller board

Limit switches are located on the same connector. The connection diagram is shown below. To indicate the limit switches it is convenient to use the LEDs designed for the necessary current.

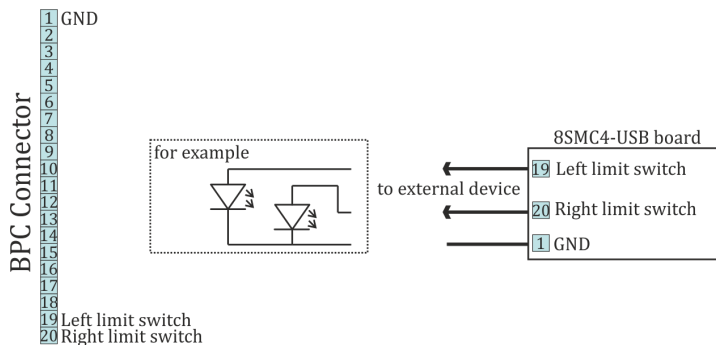

Connection of the limit indicators to the controller board

One-axis and two-axis systems

LEDs on the front panel of controllers in the box (one-axis and two-axis systems) are indicators for power, status and limit switches, therefore a connection diagram is not required.

Multi-axis system

In the multi-axis system the signals of indication output to the external DB-25 connector.

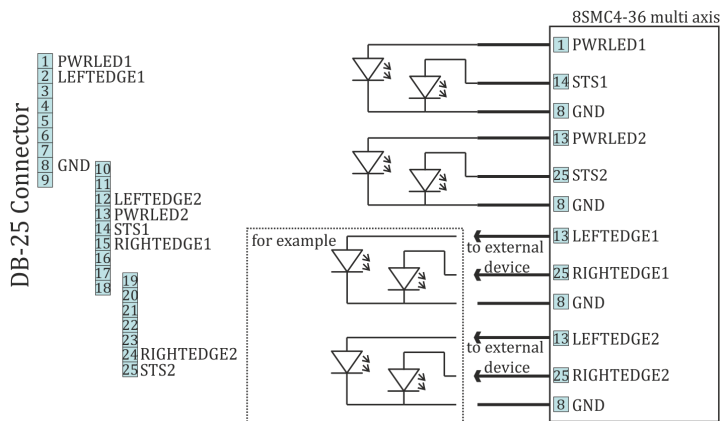

Connection of Power, Status and limit indicators to the multi-axis system

4.5.2. Operations with magnetic brake

There is an output pin on BPC connector for magnetic brake control, which is installed on the stepper motor shaft. Magnetic brake is used hold motor position in unpowered state.

Description of operation

Magnetic brake consists of a magnet and a spring, which performs stops the motor shaft. In case there is no voltage applied to the magnet the spring clamps the shaft in place which allows to keep motor position. When voltage is applied the spring releases the shaft.

Controller operating sequence during stage shutdown.

Engine shutdown (the time of shutdown is recorded in controller) -> magnet power supply cut off, shaft fixation -> board power supply cut off

During power-on the sequence is reversed.

Since any movement has inertia, the following parameters are set to control magnetic brake and the position fixation process:

- Time between motor power-on and brake deactivation (ms)
- Time between brake deactivation and readiness for movement (ms)
- Time between engine stop and brake activation (ms)
- Time between brake activation and power-off (ms)

If magnetic brake function is turned off then controller will constantly transmit brake release signal. This allows to move engine equipped with magnetic brake without rotor fixation during pauses. If winding poweroff function is turned off then controller will only pause between brake switching and movement start/stop.

All magnetic brake settings can be changed online and brake will be switched to the mode which would be active in case if the setting would have a new value. For example a large increase of brake activation delay when the brake is already active will lead to brake deactivation and countdown to the new delay value. It is also possible to turn on or off magnetic brake itself or winding power function.

Type	TTL
Active condition (brake is released)	0.3 V
Passive condition (brake is not powered)	0 V
Operational current	no more than 4 mA

Output electric parameters

Magnetic brake setting in Xilab program is described in [Brake settings](#) section.

Connection diagram

For operation with the magnetic brake a special board controlled by digital signal is used. One-axis and two-axis systems, which equipped with this board and able to work properly with magnetic brake are available separately (look [below](#)).

Controller board

A contact for the magnetic brake control is located on the [BPC connector](#).

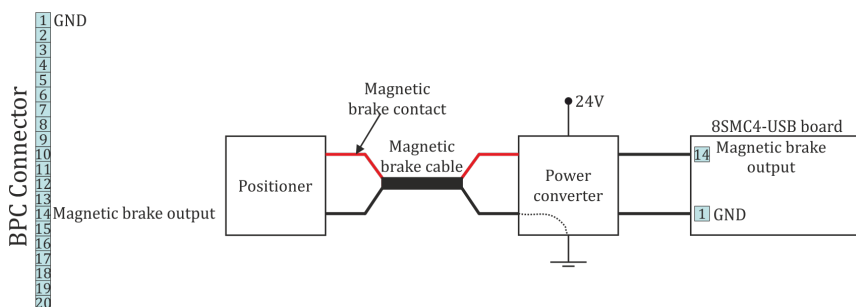

Connection of magnetic brake to the controller board

Power converter is a converter from digital signals to power. If magnetic brake output is high, the magnetic brake of stage has 24V on its power input. If it is low, the magnetic brake has 0V on its power input. In the most common case a scheme with transistor and diode is used. For more detailed information please contact us: 8SMC4@standa.lt.

One-axis and two-axis systems

In order to use magnetic brake check if your controller system is equipped with a special converter board. Models which meets this demands can be identified by letters **BR** in its title, for example **8SMC4-USB-B8-1BR**

Contact pin responsible for magnetic brake control in boxed versions of controller is located on the [D-SUB 9 pin connector](#). A connection diagram is shown below. [Two-axis](#) systems are supplied with only one axis which compatible with magnetic brake.

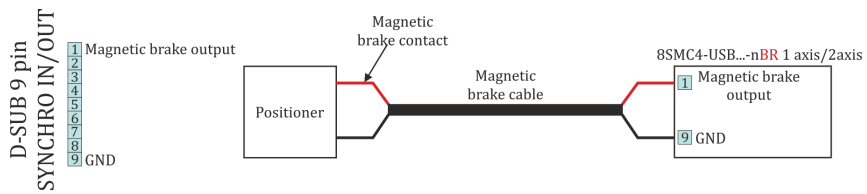

Connection of magnetic brake to one-axis or two-axis systems

Multi-axis system

In the **multi-axis** system magnetic brake is not used.

4.5.3. Joystick control

General information

Controller accepts an input from an analog joystick with voltage in 0-3 V range. Voltage in the equilibrium (central) position and voltage in minimum and maximum position can be set to any value from the working range, if the following condition holds: minimum position < central position < maximum position. Controller uses digital representation of joystick input values: 0 V corresponds to a value of 0 and 3 V corresponds to a value of 10000.

To stop movement in the central position a DeadZone option is available, which is counted from the central position and measured in percent. Any joystick position inside deadzone leads to the stopping of the movement by the controller. A larger than deadzone deviation of the stick starts controller movement with the speed which is calculated from the deviation. One can reverse the joystick with a reverse flag which can be useful to keep "right joystick offset means movement to the right" correspondence for any physical orientation of the joystick and the stage.

Movement speed has an exponential dependence on joystick deviation from the center. This enables one to reach high precision through small joystick shifts and high speed through large ones. Nonlinearity parameter can be varied. If the nonlinearity parameter is zero, then the motor speed will linearly depend on joystick position.

The following graph shows dependence of movement speed on joystick position for the following settings:

Central deviation	4500
Minimum deviation	500
Maximum deviation	9500
Dead zone	10%
Maximum movement speed	100

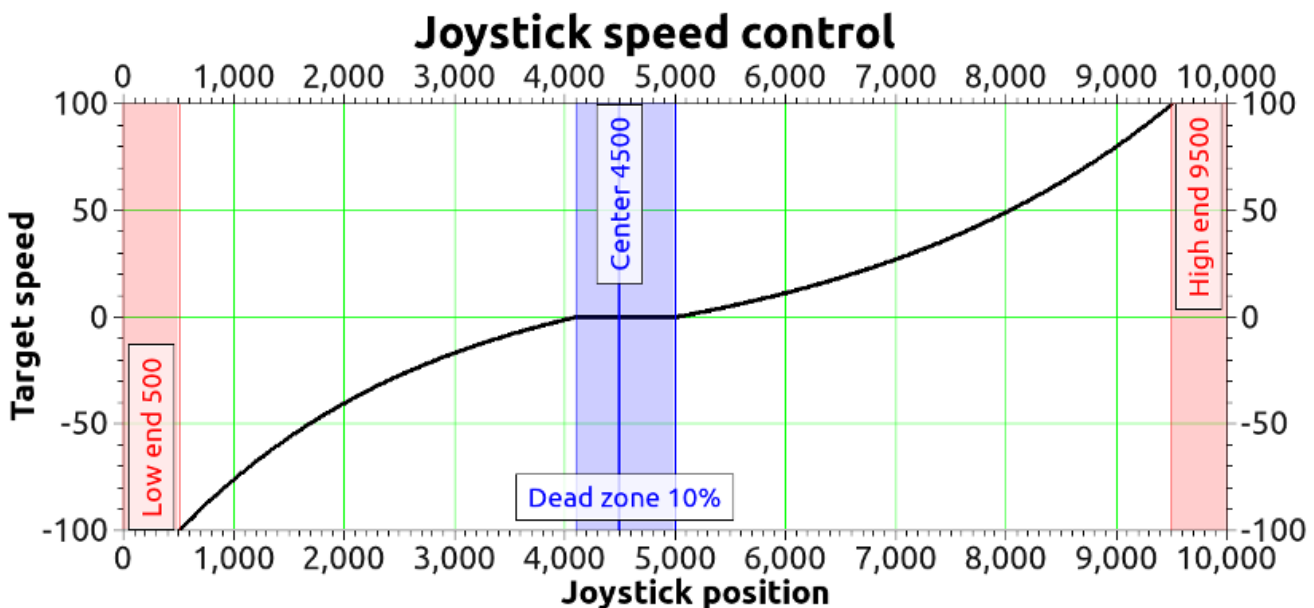

An example of motion speed dependence on joystick deviation.

Sometimes exponential joystick response which combines high accuracy and high speed is not enough. That's why controller supports maximum speed table. User can switch between these speeds using "right"/"left" buttons. In case of right key press maximum speed is changed from $Max\ speed[i]$ to $Max\ speed[i+1]$. In case of left key press maximum speed is changed from $Max\ speed[i+1]$ to $Max\ speed[i]$. Controller starts with $i=0$. There are 10 values in the speed array. If both integer and fractional parts of $Max\ speed[x]$ are equal to zero then it isn't possible to switch to this speed from $Max\ speed[x-1]$. This is made so that a user can limit speed array size. An attempt to get out of array bounds will also lead to nothing.

Controller has contact debouncing on control buttons. For keypress to register button press should last longer than 3 ms.

If joystick sits within dead zone for more than 5 seconds it will be logically considered to be out of deadzone only when it has been physically out of deadzone for more than 100 ms. This allows user to release joystick and to be confident that even occasional noise on joystick output won't lead to unnecessary motor motion. While joystick is within *Dead zone* the controller can receive any commands from computer including motion commands, home position calibration commands, etc. If during command execution joystick is brought of *Dead zone* the motion command is canceled and motor is switched to joystick control. This allows the user to turn on joystick control mode and use it only when necessary.

Everything that is related to movement under the control of controller commands is also applicable to joystick movement. This includes acceleration, maximum speed limit, windings poweroff delay, magnetic brake, backlash compensation, etc. For example, if you suddenly release joystick handle and let it return into the deadzone, then, if corresponding modes are on, controller will gradually slow the motor, make a backlash compensation motion, stop the motor, fix the motor shaft with the magnetic brake, smoothly reduce current and switch off windings power.

"Left"/"right" button connection is described in [Left-right buttons control](#).
 MaxSpeed[i] and DeadZone parameter change is described in [Settings of external control devices](#).

Connection diagram

IMPORTANT. Analog inputs for joystick connection are designed for a range of 0-3V. Be careful and do not exceed voltage for joystick contacts.

Controller board

A contact for joystick control is located on the [BPC connector](#).

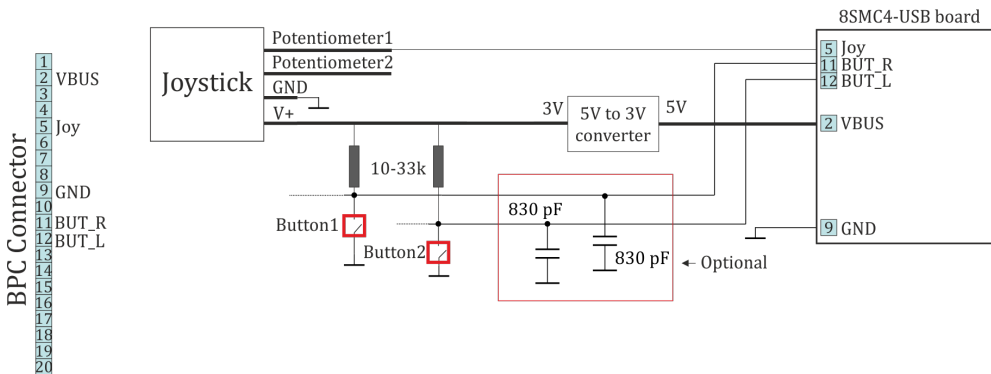

Connection of joystick to the controller board via BPC connector

One-axis and two-axis systems

[Joystick connector](#) is available only in [two-axis](#) system. A connection diagram is shown below.

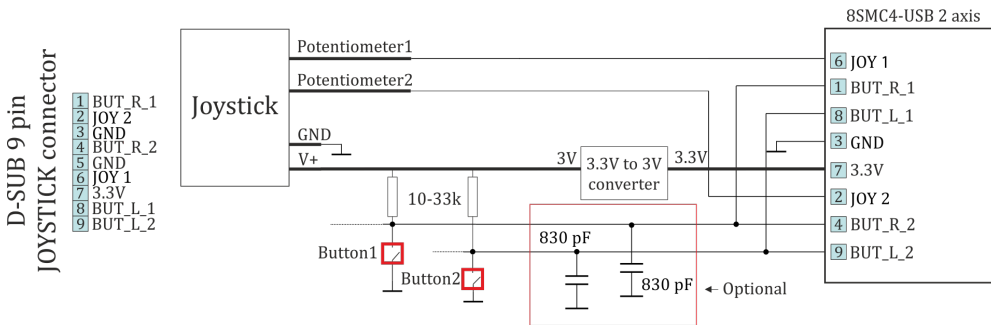

Connection of joystick to the two-axis system via D-SUB 9 pin connector

Multi-axis system

In the multi-axis system joystick pins are located on the [external DB-25 connector](#)

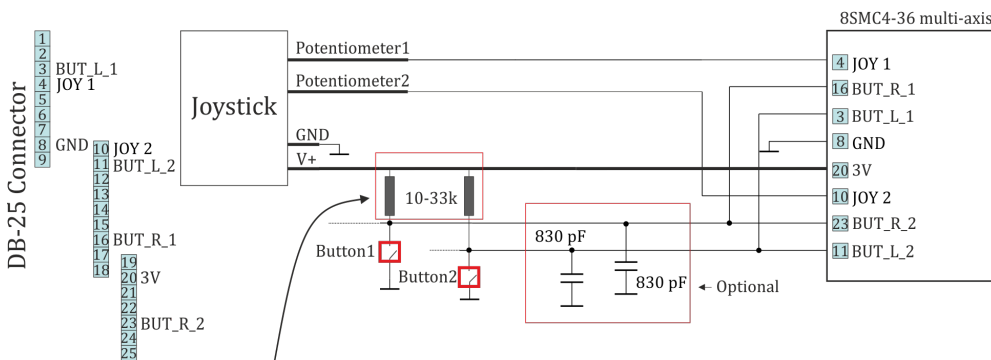

Note: only for mb4xbb boards v1.0 and v1.1

Connection of joystick to the DB-25 connector of multi-axis system

mc4xbb is the module board of [multi-axis](#) system

4.5.4. Left-Right buttons control

For each system it is possible to control the movement of a motor with the buttons. Active button state is programmable and can be logical zero or one. Controller supports a 10-item speed array `MaxSpeed[0-9]`, which is used both for [joystick](#) and button control.

The buttons control settings are read/written by commands `SCTL/GCTL` (`set_control_settings/get_control_settings`).

- If a left or right button is clicked then motor does a shift on an offset, specified by `DeltaPosition` and `uDeltaPosition`.
- If a left or right button is pressed and held for longer than `MaxClickTime`, then motor starts moving with `MaxSpeed[0]` and counting down to `Timeout[0]`. After `Timeout[i]` microseconds have elapsed speed is changed from `MaxSpeed[i]` to `MaxSpeed[i+1]` for any `i` between 0 and 9 (inclusive).
- If press the two buttons, the controller performs a [stop with deceleration](#). Holding both buttons for 3 seconds starts the [automatic calibration of the "home" position](#).

Note: You can fill only the upper part of the 10-item speed array if you don't need all of them. Controller changes its speed to the next one only if the target speed is not zero and the timeout is not zero. For example, if `MaxSpeed[0]` and `MaxSpeed[1]` are nonzero and `MaxSpeed[2]` is zero (both step and microstep part), then the controller will start moving with `MaxSpeed[0]`, then change its speed to `MaxSpeed[1]` after `Timeout[0]` and will keep moving with `MaxSpeed[1]` until the button is released. You can also set `Timeout[1]` to zero and leave `MaxSpeed[2]` set to any value to achieve the same result.

Controller obeys its movement settings (with the exception of target speed). For example, when changing its speed from `MaxSpeed[i]` to `MaxSpeed[i+1]` controller will either accelerate with set acceleration value or change its speed instantly if acceleration is disabled.

The default state is set according to the voltage levels of the buttons table 4.5.4.1. The state of each button can be software inverted. When active, the button is considered to be down. It does not matter how the condition is active (after changing the invert states, or when changing the voltage level at the physical impact of a button). The controller uses button contact debouncing. The button is considered pressed if active state lasts for longer than 3 ms.

Type	TTL
Logic zero level	0 V
Logic one level	3.3 V

Table 4.5.4.1 - Output parameters



WARNING. When you turn on or reboot the controller at the input voltage level of the button is present, which is considered to be active, the controller will accept it as a button is pressed, and begin to obey the [rules described above](#).

Connection diagram

Controller board

"Right" and "Left" control buttons can be connected to the controller board via [BPC connector](#) for a motor motion control. There are no integrated pull-down resistors for setting of input potential by default, that's why it is necessary to use (pull up) and (pull down) resistors scheme.

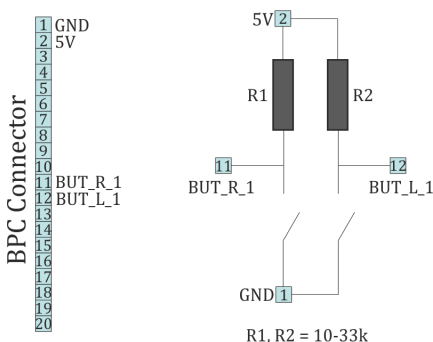

Scheme of buttons connection to the BPC connector

One-axis and two-axis systems

For controllers in case user buttons already placed on the front panel. However it is possible to connect custom buttons to the corresponding contacts that located on the [D-SUB 9 pin connector](#) and available only in [two-axis](#) system. Connection diagram is shown below.

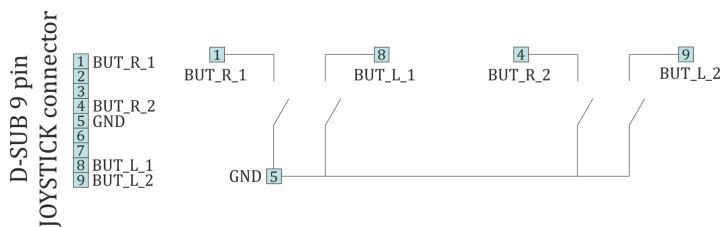

Scheme of buttons connection to the HDB-26 connector

Multi-axis system

In the multi-axis system buttons are located on the [External Control connector](#). A connection diagram depends on the [module](#) board version. For old boards (mbxbb v1.0 и v1.1) use the scheme with pull-up resistors.

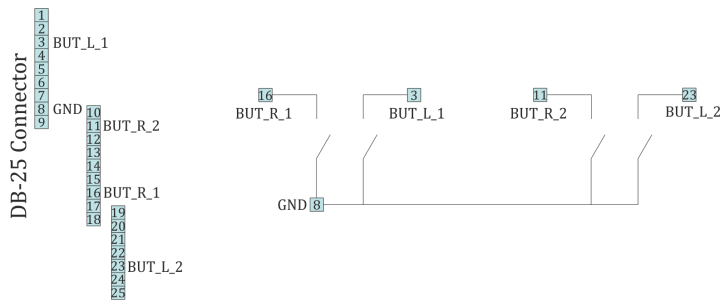

Scheme of buttons connection to the DB-25 connector

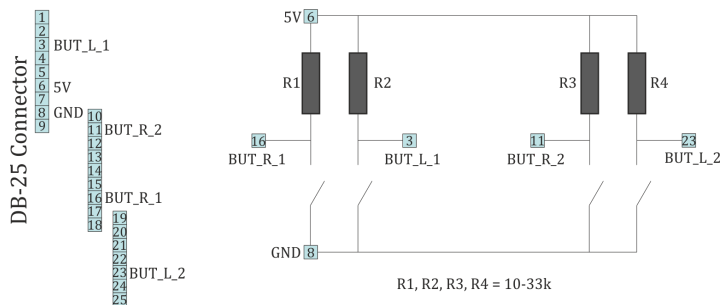

Scheme of buttons connection to the DB-25 connector for old modules v1.1 and lower

4.5.5. TTL synchronization

Principle of operation

TTL-synchronization is used to synchronize controller motion with external devices and/or events. For example, the controller can output synchronization pulse each time it moves a certain distance. Vice versa, controller can shift a certain distance on incoming synchronization pulse, for example from an experimental setup which is ready to move to the next measurement position.

To use mechanical contacts as an input synchronization signal a contact debouncing is provided. One can set minimum input pulse length which is recognized as a valid synchronization signal. An active state is a logical one (see table 4.5.5.1), and a raising edge is considered to be the start of a signal. However, if for some reason this is undesirable, both options may be inverted independently.

Type	TTL
Logic zero level	0 V
Logic one level	3.3 V

Table 4.5.5.1 - Input parameters

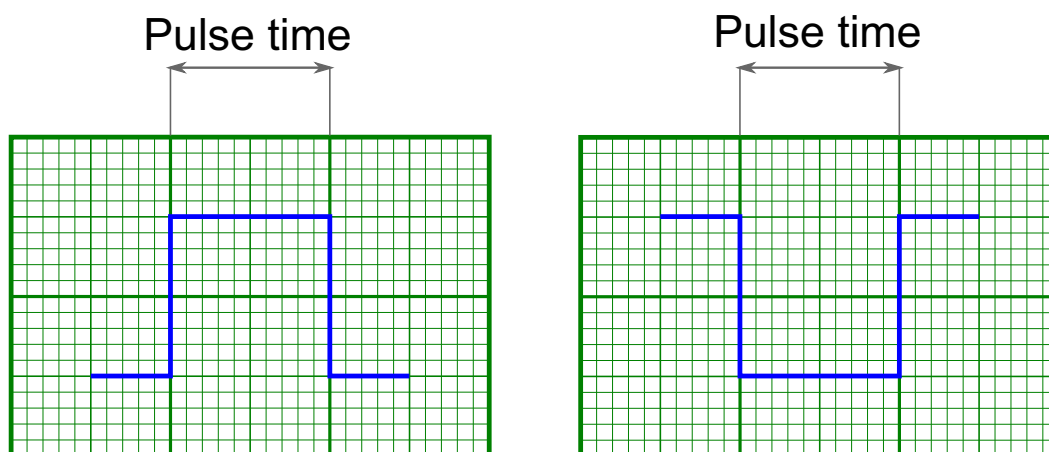

Inversion of input and output synchronization pulse illustrated

Note. If simultaneous start of several controllers in a multiaxis system is desirable, minimum input pulse length should be the same for all controllers. Contact debouncing should not be used in systems with no mechanical contacts and short noise pulses in synchronization input channel. One should use an RC-circuit which would filter these noise pulses instead.

Synchronization is important in multiaxis systems because it allows one to start movement on several axes simultaneously. To do this all axes are prepared to start the movement, all slave axes are set to start moving on input synchronization pulse, one master axis is set to output a synchronization pulse on the start of the movement. Master axis output is connected to slave axes' input. In this setup any movement of the master axis leads to immediate response of all connected axes.

Note. One should set minimum input sync pulse length to 0 if this kind of connection is used. This disables contact debouncing, but since there are no mechanical contacts it is not needed. If minimum input sync pulse length is not zero then to avoid desynchronization of master and slave axes one should set input sync pulse length the same for all controllers, connect syncout to both master and slave inputs and issue start command by activating input manually.

Synchronization input and output are independent from each other and other means of motion control. Control through [XiLab application](#) or any other user application, [joystick control](#) and [left-right buttons control](#) are independent of input/output synchronization state. Last command always takes priority. For example, a movement command sent from XiLab will cancel current movement which happened because of input sync pulse, but will not affect output sync state. Next input sync pulse will cancel current movement initiated by user program and will replace it with movement command according to sync in settings.

Note. Sync in settings may be saved in controller flash (non-volatile) memory. In this case everything related to synchronization may also be said about autonomous controller operation. For example, you may set up shift on offset on syncin pulse with syncout pulse on movement stop and connect the controller to a standalone measurement device, which starts measurements on its own input sync pulse and outputs a sync pulse on measurement end. Then you can run such a system without a PC, because after the first sync pulse all measurements and movements will happen automatically.

Connection

The controller is supplied with two TTL-sync channels on the [BPC connector](#).

Sync in

Synchronization input has a setting, which defines minimum syncin pulse length which may be registered. This length is measured in microseconds. Use this setting to decrease controller sensitivity to noise. Synchronization input may be turned on or off. If it is on, then a sync in pulse will lead to a situation as if [Predefined displacement mode](#) command has taken place, which takes its *Position* and *Speed* from syncin settings. If syncin settings are changed during the time the movement takes place it will not change current movement parameters. Movement parameters will change on the next front on synchronization input. This designed deliberately to allow one to set up next shift parameters in multi-axis systems during movement.



WARNING. When you turn on or reboot the controller at the input voltage level of the synchronize input is present, which is considered to be active, the controller interprets it as if [Predefined displacement mode](#) command has taken place.

Note. *Position* and *Speed* are two separate variables which also may be saved in non-volatile controller memory. They are used only with synchronization input.

Note. Syncin movement obeys acceleration, max speed settings and all other settings which are related to motion. Their incorrect setting may disrupt coordinated movement in multi-axis system.

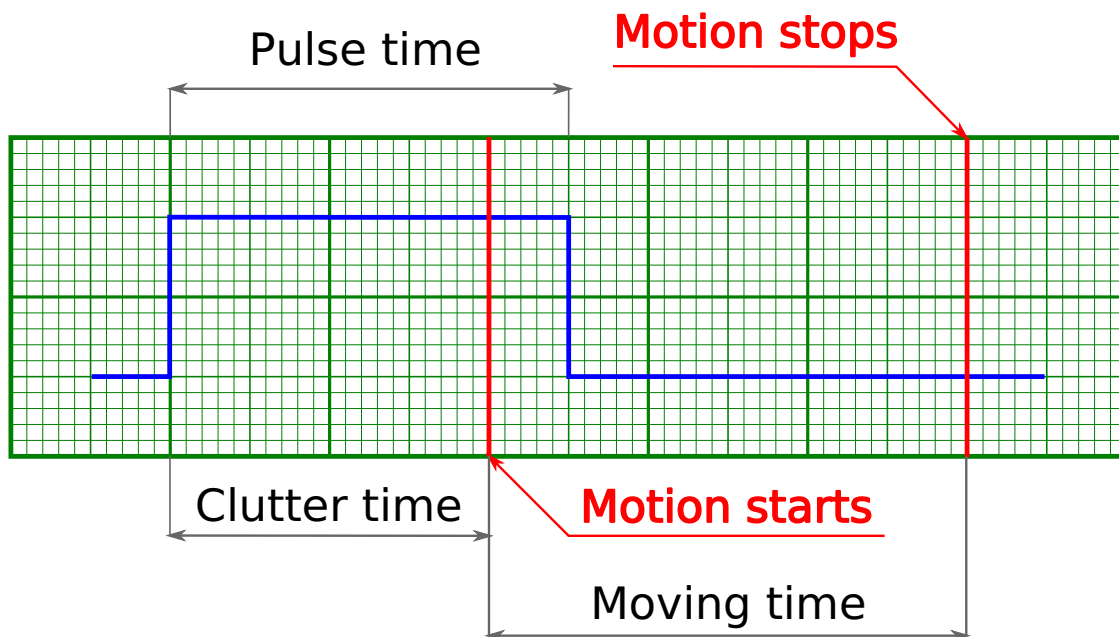

Movement starts because input pulse is longer than debounce time

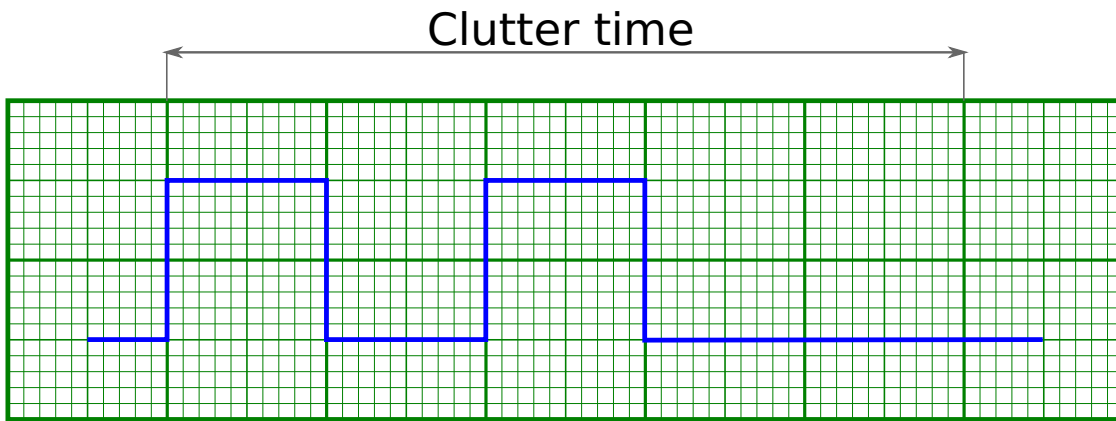

Movement does not start because input pulses are shorter than debounce time



Warning. If a second syncin pulse is received while controller is still moving then the end position will be offset by two times the shift distance from the start, if a third pulse is received, then by three times, etc.

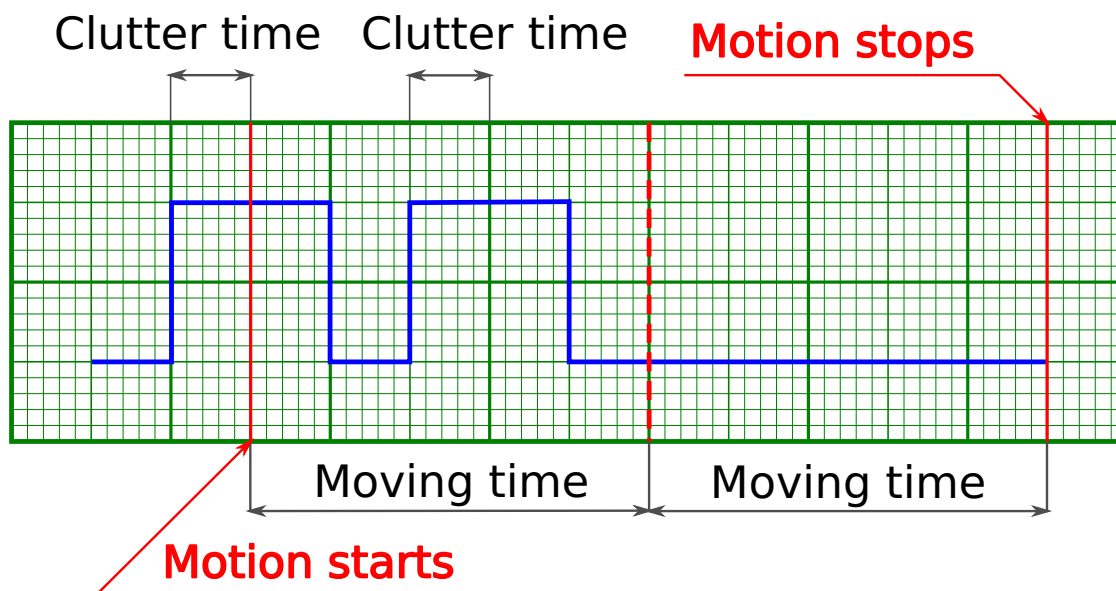

One-time movement with double shift length because second syncin pulse came in before the end of the movement

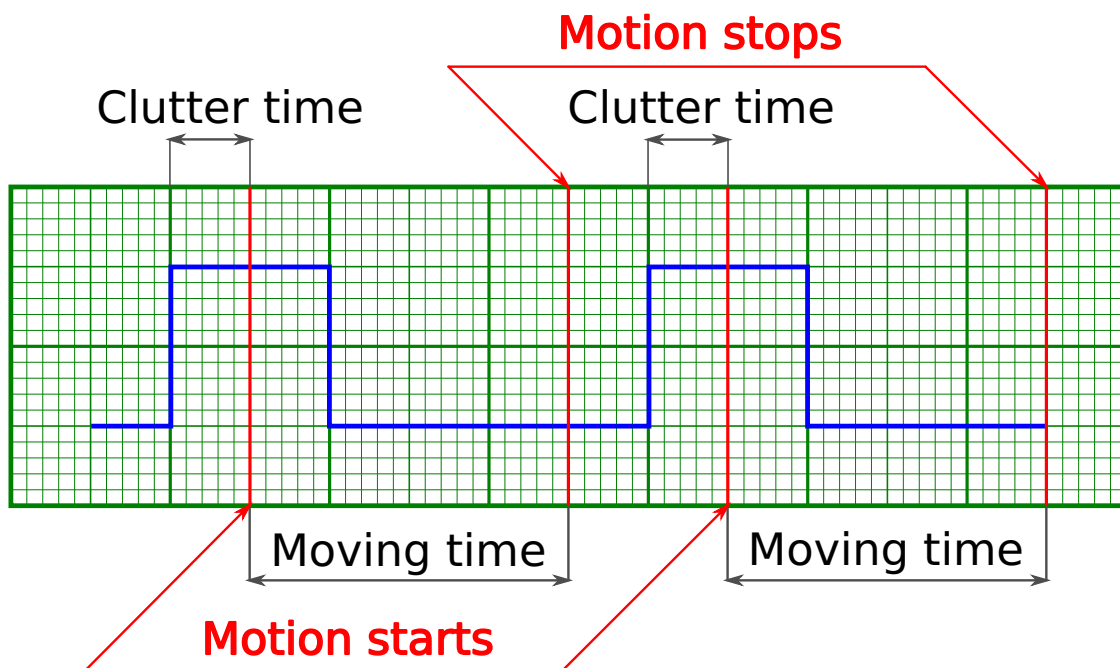

Two separate shifts with two start and two stop phases

Default setting is active state is one, movement on raising edge. Synchronization input may be inverted to the active state is zero, movement on trailing edge.

Note. Inverted synchronization input setting will lead to the change in the definition of active/inactive state which may be seen, for example, in [controller status](#). However, programmatical inversion of the syncin state by itself will not lead to the start of the movement, even if the transition happened into the active state.

Sync out

Output synchronization is used to control external devices tied to controller movement events. Sync out pulse can be emitted on start and/or stop of the movement, and/or on each shift on the preset distance. *ImpulseTime* setting defines the length of sync pulse, either in microseconds or in distance units. Synchronization output can be switched into general purpose digital output mode. In this mode it is possible to set zero/one output logic level programmatically.

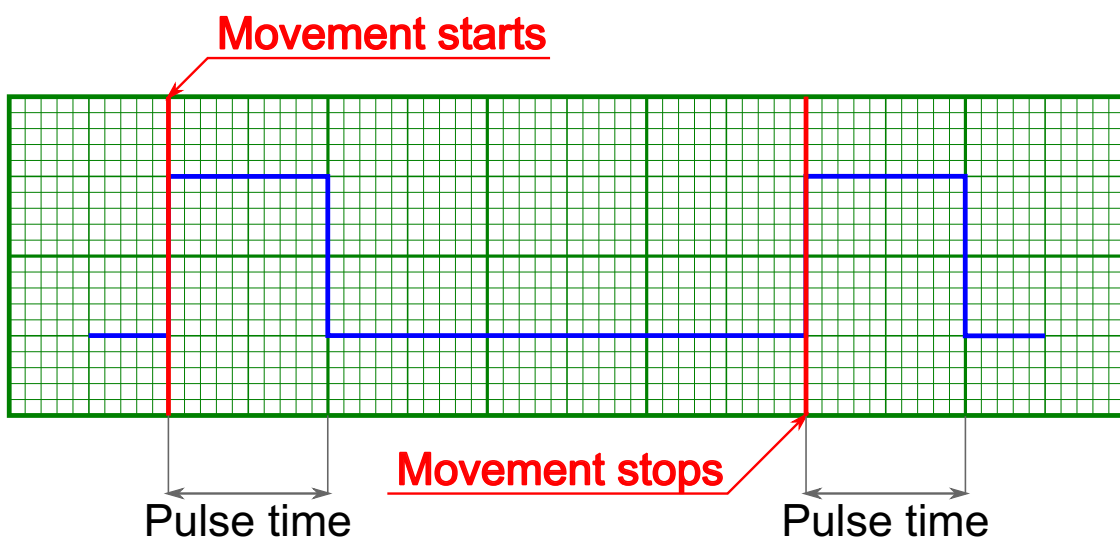

Sync out pulses generated on start and stop of the movement (fixed length pulse)

Note. If syncout pulse length is measured in distance units and, for example, is equal to 10 stepper motor steps and "syncout pulse on stop" mode is active, then the active state on synchronization output will be set on the movement end, but will be cleared only when the motor will move 10 more steps during the next movement.

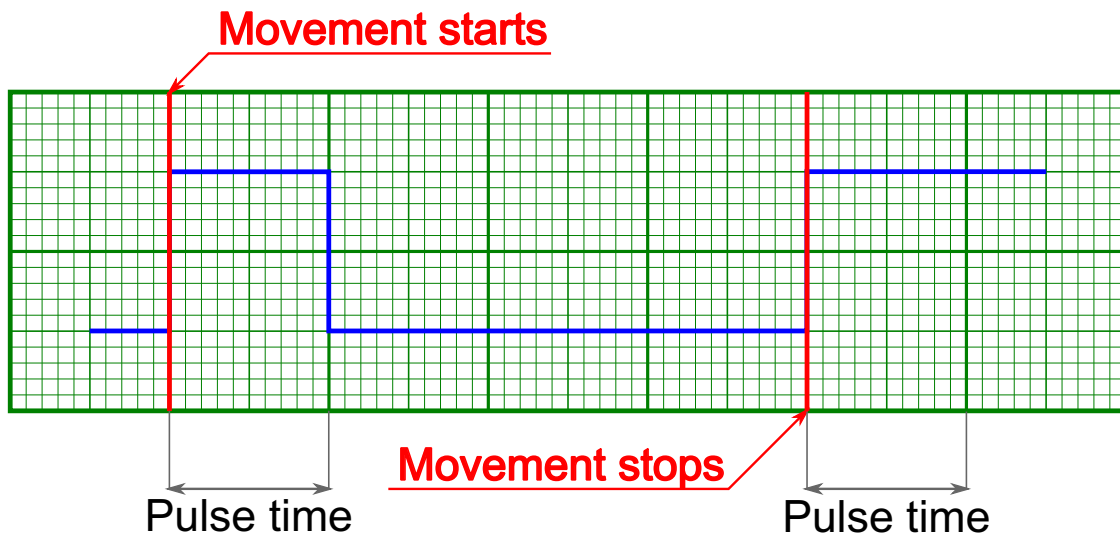

Syncout pulses generated on start and stop of the movement (pulse is measured in distance units)

Note. If you wish to reconfigure synchronization output and are not sure which state is it in, change its state to general purpose output and set the desired logic level.

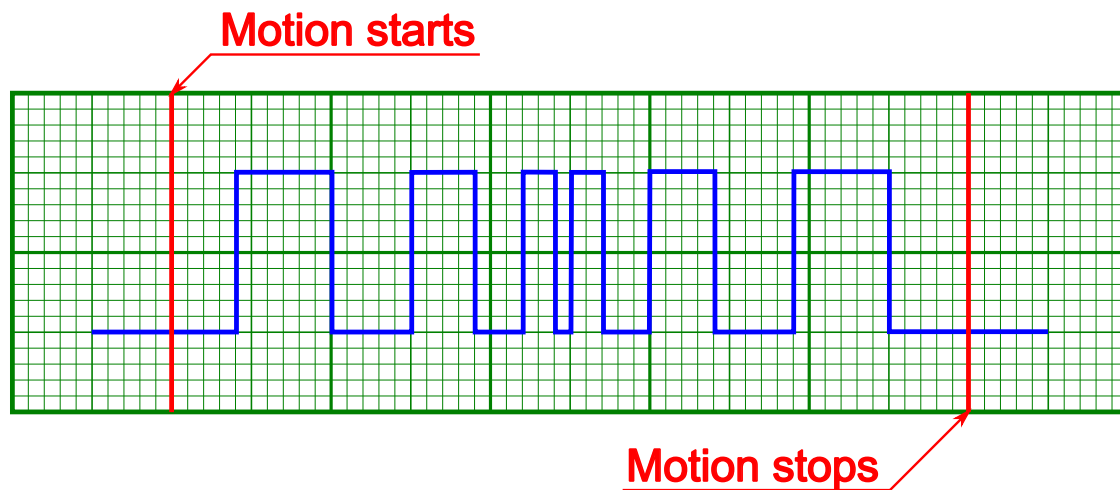

Sync out pulses on movement with acceleration and "generate on shift" mode (pulse length measured in distance units)

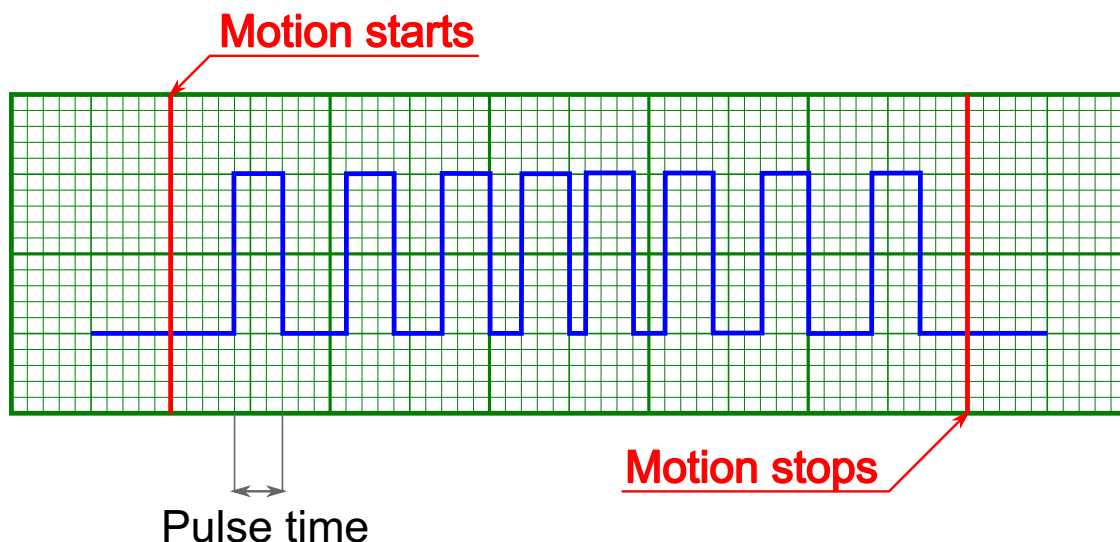

Sync out pulses on movement with acceleration and "generate on shift" mode (pulse length measured in microseconds)

Note. Periodic syncout pulse generation imitates revolution sensor with reducing gear. Coordinates which trigger syncout pulse generation are counted from zero position and not from the position the controller is in at the start of the movement. For example, if synchronization output is set up to generate pulses every 1000 steps then pulses will be generated in positions 0, 1000, 2000, 3000, etc. Pulse generation works when moving in both directions. Pulse is generated when the quotient of current coordinate and pulse generation period changes. That is, pulse is generated when position 1000 is reached when moving in the direction of increasing position and it is generated when position 1000 is left when moving in the direction of decreasing position. Also, syncout pulse is always generated when position 0 is reached from any direction (including the case when position is reset by the ZERO button).

Note. Whenever syncout pulses overlap they are merged into one pulse.

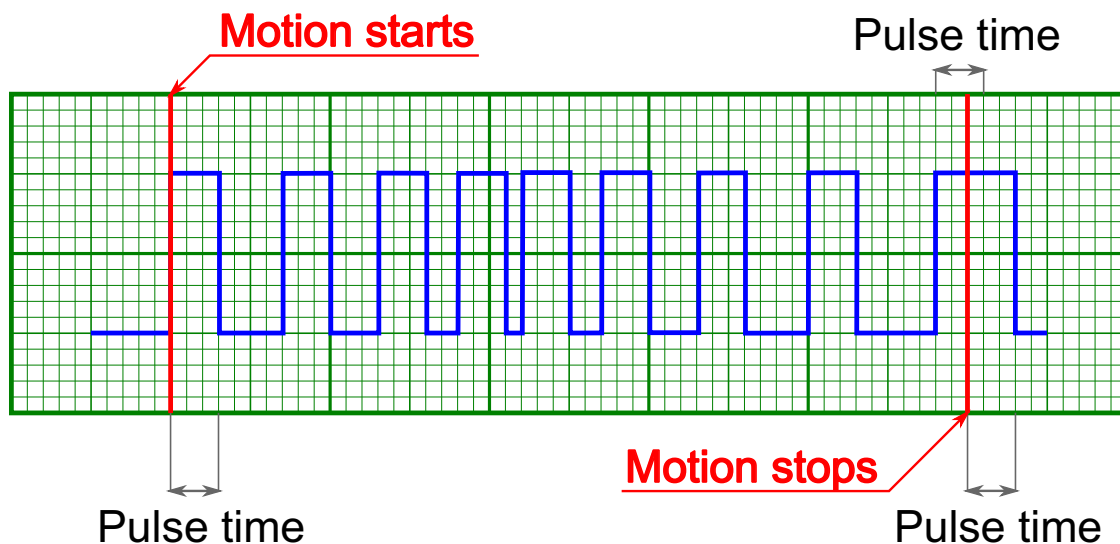

_Syncout pulse merge illustrated, pulse generation on start, stop and shift on offset (pulse length measured in microseconds)

Synchronization settings setup in XiLab is described in [Synchronization settings](#) section.

Connection diagram

Controller board

[Controller board](#) contains two TTL-channels of synchronization on the [BPC connector](#).

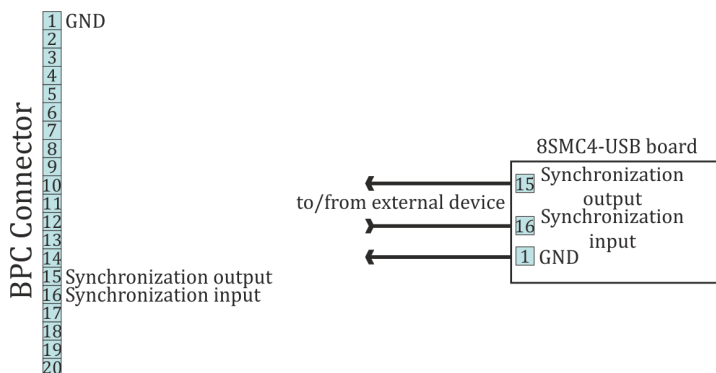

Scheme of connection to the synchronization channels for the controller board

One-axis and two-axis systems

Synchronization signals on the one-axis and two-axis systems are located on the D-SUP 9 pin connector.

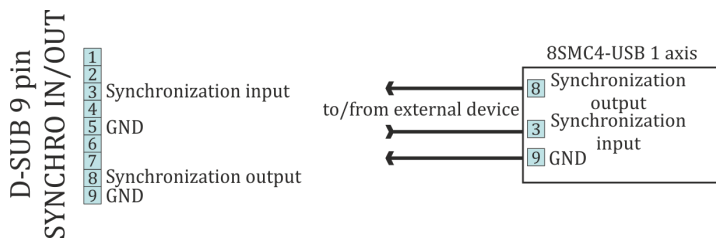

Scheme of connection to the synchronization channels for the one-axis system

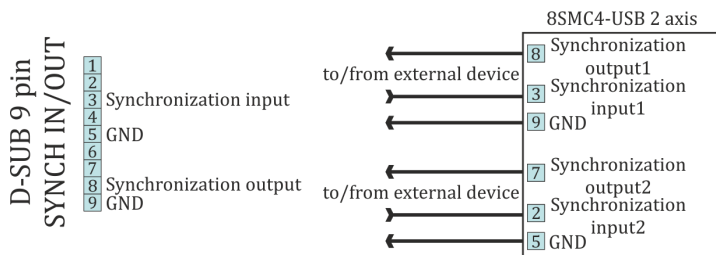

Scheme of connection to the synchronization channels for the two-axis system

Multi-axis system

Synchronization signals in the multi-axis system outputs on the DB-25 connector and related to the module containing 4 controller boards. For each module there are two DB-25 connectors and their synchronization contacts are the same.

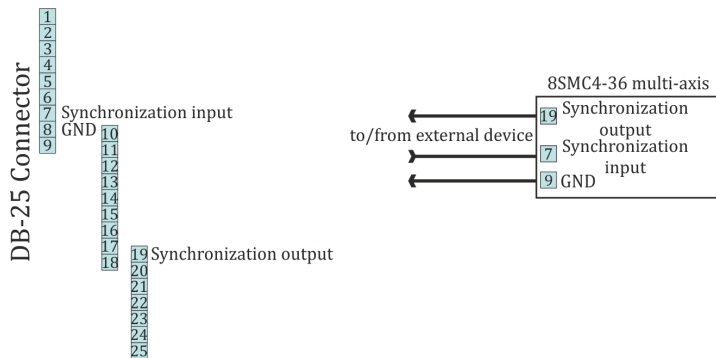

Scheme of connection to the synchronization channels for the multi-axis system

4.5.6. Multiaxis system design

Controller axes in multiaxis systems are identified by the controller serial number. Each controller has its own unique serial number, which may be seen in XiLab software on [About controller](#) page. One can read controller serial number using `get_serial_number` function (see [Programming guide](#)).

Multiaxis systems based on this controller are assembled using an active backplane based on a USB-hub or an external USB-hub.

IMPORTANT. It is recommended to base backplanes on a USB-hub with galvanic isolation from the PC and an additional power supply or a 36 V -> 5 V converter, because this provides higher noise immunity and guarantees sufficient 5 V power.

For proper multiaxis system functioning one should first connect all controllers to the power and USB connectors (place controllers on the backplane).

Then, in any order, do all of the following:

- Connect power to the backplane
- Connect external devices
- Connect master controller to the USB

Note. Additional 5 V power supply requirements: output current no less than 250 mA per axis, 400 mA per axis for full functionality.

Multiaxis connection diagram implies connecting power supply to pins 1 and 2 of the BPC connector and connecting data lines D-/D+ from the USB hub to pins 3 and 4 of the BPC connector.

Power is connected next:

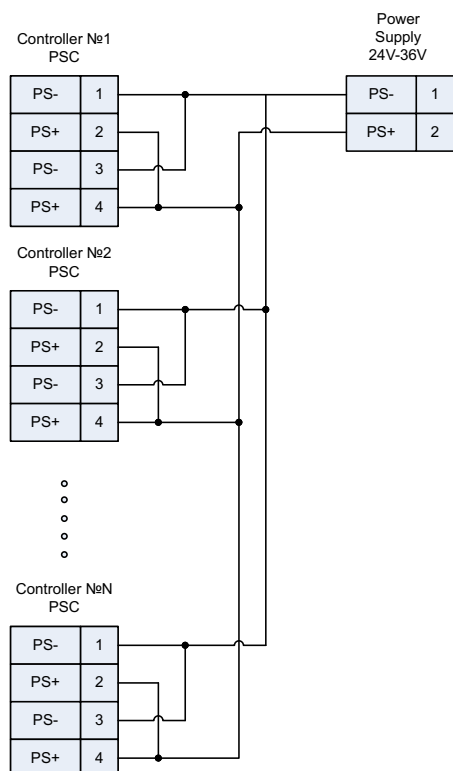

Controller connection diagram in multiaxis configuration

PSC - Power Supply Connector, used to connect power supply to the controller

BPC - Back Panel Connector, used to connect accessories to the controller

4.5.7. General purpose digital input-output

Output is located on [BPC connector](#). It allows user to configure it as input or output. Logical level one is considered to be active. However it can be inverted so that logical level zero is considered active.

Type	TTL
Logic zero level	0 V
Logic one level	3.3 V

Table 4.5.4.1 - Input parameters

In input mode you can get information about logical level on input (see [Controller status](#)), or initiate the following actions during transfer to active state (or during transfer to non-active state if the input is inverted):

- Perform *STOP* command (quick stop).
- Perform *PWOF* command (windings power supply switch off).
- Perform *MOVR* command (shift to the given distance with last used settings).
- Perform *HOME* command (automatic position calibration).
- Enter *Alarm* state (turn off H-bridges and wait reinitialization).

It does not matter how the state of the input becomes active (after changing the invert states, or when changing the voltage level). The controller uses a software debounce the input. Initiating the action takes place only when the active state of the input buttons lasted for more than 3 ms.

WARNING. When you turn on or reboot the controller at the input voltage level of the input is present, which is considered to be active, the controller interprets it as a signal to trigger any of the actions.

Note. Digital input has weak pull down to the ground.

In output mode it is possible to set active or inactive logic level on the following events:

- `EXTIO_SETUP_MODE_OUT_MOVING` – Active state during motor movement.
- `EXTIO_SETUP_MODE_OUT_ALARM` – Active state when controller is in Alarm state.
- `EXTIO_SETUP_MODE_OUT_MOTOR_ON` – Active state while power is supplied to the motor windings.
- `EXTIO_SETUP_MODE_OUT_MOTOR_FOUND` – Active state while motor is connected.

Logic type	TTL	3.3 V
Update frequency	1 kHz	
Nominal current	5 mA	

Table 4.5.7.2 - Output technical characteristic

Connection diagram

Controller board

Digital output is located on the [BPC connector](#)

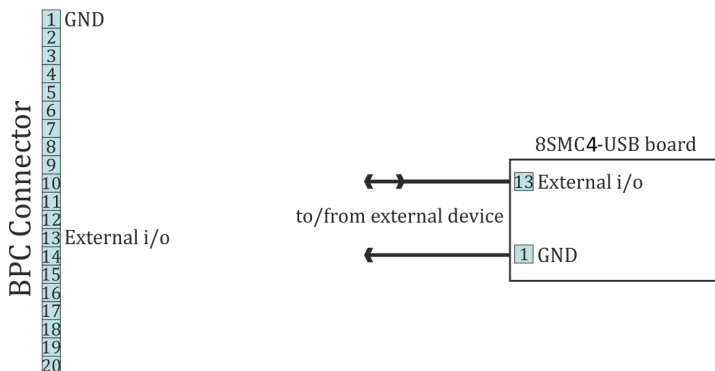

Scheme of connection to digital input/output for the controller board

One-axis and two-axis systems

Among two box versions, only two axis system has the digital input/output. Corresponding contacts output on the [HDB-26 connector](#).

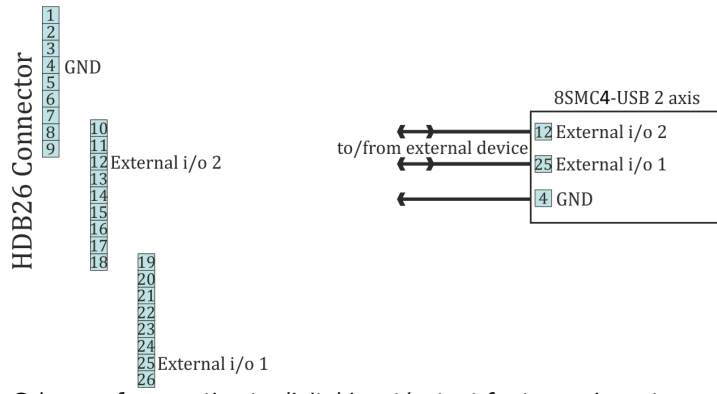

Scheme of connection to digital input/output for two-axis system

Multi-axis system

[Multi-axis](#) system does not have contacts responsible for general purpose digital input/output.

4.5.8. General purpose analog input

Analog input may be used for other purpose. For example, it can be used to measure any external signal. Value at the analog input may be read by the *GETC* command and is visible in the *XiLab charts*.

This controller represents analog input values as a number in 0..10000 range. Analog input pin is located on [BPC connector](#).

IMPORTANT. Analog input voltage should not go outside of 0-3 V range. If this voltage is exceeded errors in analog input and other controller subsystems are possible! This may also damage the controller or connected motor.

Signal voltage	0-3 V
Scanning frequency	1 kHz

Table. Input parameters.

Connection diagram

Controller board

For the [controller board](#) analog input contact is located on the [BPC connector](#).

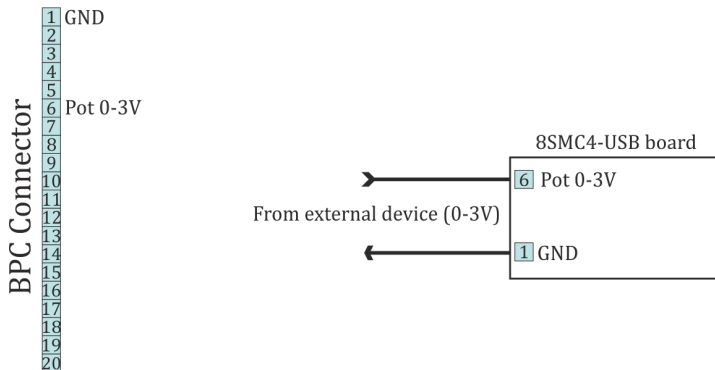

Scheme of connection to analog input for the controller board

One-axis and two-axis systems

Only [two-axis](#) system has general purpose analog input on supplementary [HDB-26 connector](#).

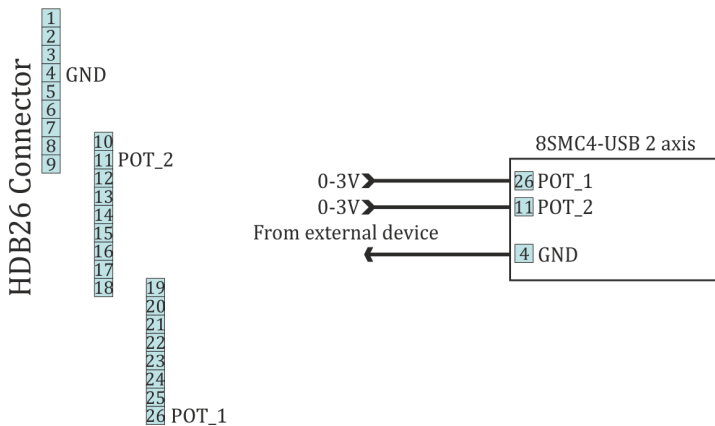

Scheme of connection to analog input for the two-axis system

Multi-axis system

[Multi-axis](#) system does not have general purpose analog input.

4.5.9. External driver control interface

Interface allows to control any external driver with a help of 3 standard signals: enable, direction, clock. This mode is convenient when controller power capability is not enough but it is desirable to use its capabilities such as limit switches, revolution sensor, position control, scripting language, multiaxis systems, joystick/button control, magnetic brake, etc. For example, for creation of multiaxis system with one powerful lifting axis which is controlled by external controller and two less powerful horizontal axes, you can use XiLab with 3-axis interface and its scripts and also synchronize the motion of all three axes. I.e. external driver replaces only power part of the controller.

Clock signal defines the quantity of signals in the given Direction (logical one to the right, logical zero to the left). Displacement is a minimum step in the current settings of step division. For step division 1/32 there will be 32 impulses per one step. Don't forget to set external driver in such a way that it would use the same step division.

WARNING. Clock signal frequency in the given controller is limited by 78 kHz. That's why to reach necessary speed one might need to reduce step division. For example, if rotation speed of 4000 steps per seconds is needed it is necessary to use 1/8 step division or less.

Type	TTL
Logical zero level	0 V
Logical one level	3.3 V

Output parameters of external driver control

Connection diagram

WARNING. Outputs for external driver control are not sufficiently protected and can be damaged in case of incorrect usage. Proper connection and necessary electric protections are a responsibility of an engineer who designs drivers' connection system.

Controller board

For external driver connection three outputs in [BPC connector](#) are used.

WARNING. Pin 13 is the general purpose input/output (see [General purpose digital input-output](#)), but it loses its functionality when external driver control is enabled.

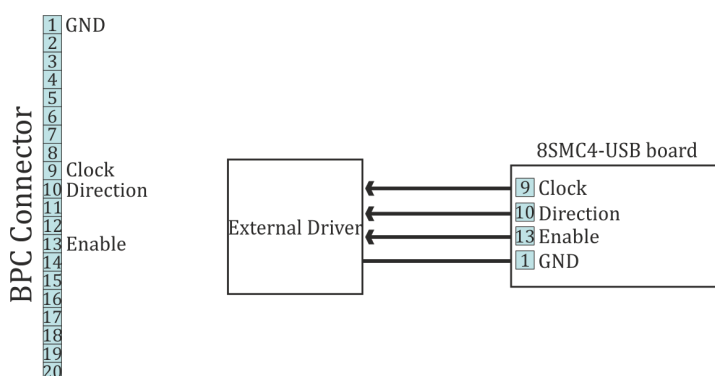

Scheme of connection to the external driver for the controller board

One-axis and two-axis systems

Only [two-axis](#) system has the external driver interface. It outputs on the [HDB-26 connector](#).

WARNING. Pins 12 and 25 are general purpose inputs/outputs (see [General purpose digital input-output](#)), but they loses functionality when external driver control is enabled.

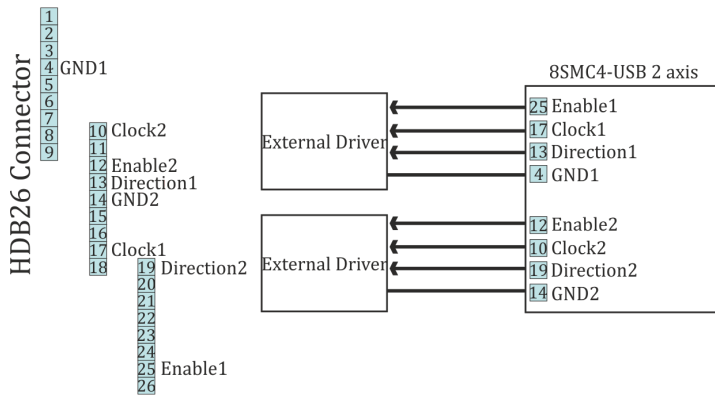

Multi-axis system

Multi-axis system does not have an interface for external driver control.

4.5.10. Serial port

Controller allows control through UART serial port with TTL 3.3 V logic. UART outputs are located on [BPC connector](#). Because of widespread availability of UART and adapters to USB, Bluetooth, Ethernet and other standard interfaces there is an option for wireless control (Bluetooth) or control over the internet (Ethernet). UART data protocol is the same as USB data protocol. I.e. it is enough to enable nonstandard serial port polling in XiLab or in libximc and the device will be found if response delay doesn't exceed two seconds. It is also possible to control controller with the help of other independently programmed micro-controller, however in this case it will be required to support [controller communication protocol](#).

UART supports the following settings.

Transfer rate	9600-921600 bit/sec
Data bits	8
Parity	enabled or disabled
Parity type	even, odd, space, mark
Stop bits	1 or 2

Note. To connect to the controller via UART one should first connect to it via USB and set required speed, parity and stop bits and then save settings to non-volatile memory. Standard settings are listed in [Communication protocol specification](#), use them if you cannot connect.

Logic type	TTL 3.3V
Maximum data transfer speed	921 kbit
Nominal output current	5 mA

Output and input parameters

Connection diagram

WARNING. High data transfer speeds through long cables in case of electromagnetic interference are impossible. If transfer errors do occur, use RC filtering circuits and reduce transfer speeds so that characteristic time of an RC-circuit is at least 4 times less than time needed to transfer a single bit. RC-circuit characteristic time is chosen based on the circumstances.

Controller board

For the [controller board](#) UART outputs are located on the [BPC connector](#).

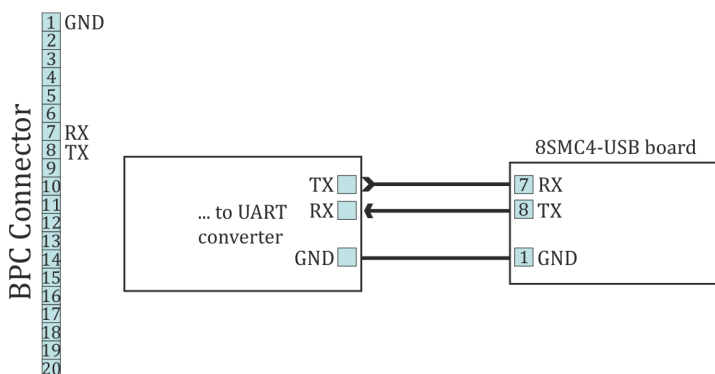

Recommended scheme of connection to serial port pins for the controller board

One-axis and two-axis systems

Among two box versions, only the [two-axis](#) system has UART outputs. Corresponding contacts for each axis output on the [HDB-26 connector](#).

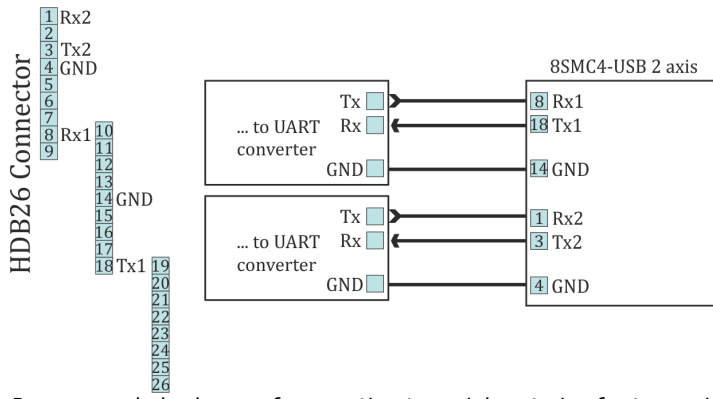

Recommended scheme of connection to serial port pins for two-axis system

Multi-axis system

Multi-axis system does not have serial port outputs.

4.5.11. Saving the position in controller's FRAM memory

Controller has a function which automatically remembers its last position. This allows one to power-off the controller after it has stopped. On the next power-on the controller will appear in the same motor position, logical position and encoder value. This will work if during the time controller was off the motor shaft was not rotated by external means.

Note. For this function to work one should wait at least 0.5 seconds after the stop before cutting the power. Position is saved even if the controller was powered off during movement, however in this case its saved position will not be exact and a new [calibration](#) will be needed.

4.5.12. The Standa stages detection

Newest Standa positioners (please check with the manufacturer for the list of exact models) have an option to store settings and informational parameters in the internal positioner memory. This chip is flashed with correct settings, which allows one to skip optimal positioner configuration and to start working with the positioner right out of the box. This memory chip also holds user-defined positioner name (see XiLab tab [Positioner name](#)).

When this kind of positioner is connected to the controller (for more information about electrical connection please see [example of motor connection](#) and [positioner connector](#)) informational parameters are automatically loaded into the controller memory, see [Positioner specifications](#). If the EEPROM_PRECEDENCE flag was set, which indicates precedence of settings read from external memory over the settings saved in the controller flash memory (see [About controller](#)), then all controller settings except UART settings and controller name are also read and applied.

If the EEPROM_PRECEDENCE flag is set then you don't need to check and/or set positioner settings (for example limit switches orientation and position, nominal current, encoder and magnetic brake parameters, etc). All of this will be done automatically when a positioner with internal memory chip is connected. However, if this flag is set then settings from positioner memory will be loaded every time a positioner with memory chip is connected and every time the controller is powered on. That is why if you need to change some settings you need to clear this flag, change required settings and save them to controller flash memory.

Note. There is a simple rule for this flag preferred state: This flag should be true on early stages of work to embrace the simplicity of automatic settings. Later, as soon as the will be need for fine tuning the settings, this flag should be set to false, not forgetting to save this to FRAM.

Note. If a positioner with internal memory is disconnected from the controller no settings are changed.

For developers

Positioner data is stored in DS28EC20 chip connected by 1-wire interface.

Controller periodically sends reset signal to the EEPROM chip during positioner detection. If a response is received, then controller reads data from the positioner into RAM, applies settings and sets STATE_EEPROM_CONNECTED bit in status structure. In XiLab this is shown by EEPR indicator in the main window. The EEPROM is then regularly polled. In case connection with EEPROM is lost (no response to the reset signal) EEPR XiLab indicator is cleared.

Connection diagram

Outputs for connection to the memory chip are located on the [D-SUB 15 pin](#) connector for all systems ([controller board](#), [one-axis](#) and [two-axis](#) in box and [multi-axis](#)).

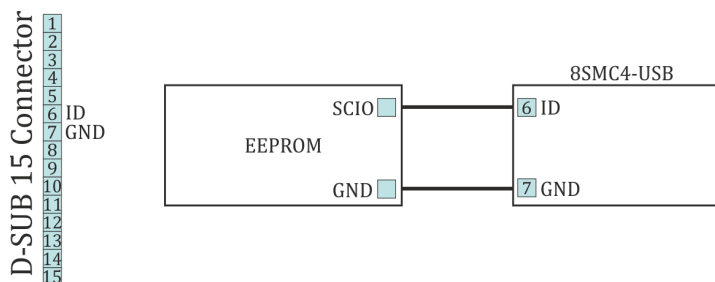

Connection diagram for external memory test

4.6. Secondary features

1. [Zero position adjustment](#)
2. [User-defined position adjustment](#)
3. [Controller status](#)
4. [USB connection autorecovery](#)

4.6.1. Zero position adjustment

Controller supports setting of zero position. This function should be used for anchor marked stages, so that anchor position matches logical zero. Also, this function is convenient to use in case there is a single chosen physical position.

To set zero position a [special command](#) is used. This will zero step/microstep position and encoder count values. Setting of zero position happens simultaneously for all position counters and will not lead to their desynchronization. Current movement command is not affected. If controller was moving to some physical position when logical position was reset to zero by this command then the movement will still end in that physical position. For example, if the controller moved towards logical position 1000 and set zero position command was sent when it was passing 200, then logical position counter will be decremented by 200 and movement will end in logical position 800.

Note. Setting of zero position when using shift on offset (see [Predefined displacement mode](#)) will not change target physical position. Next shift will happen towards the same physical position which would have happened without zero position command.

4.6.2. User-defined position adjustment

A *SPOS* command can be used if it is necessary to set position and/or encoder value to some user-defined position instead of zero. New step/microstep position and encoder count values are passed as parameters to this command. If only one of these counters is needed one should use ignore flags to filter required fields.

This command is different from set zero command in that it doesn't set target position used by *MOVE* and *MOVR* commands to zero. During movement and stopping its behavior is the same. If you issue *SPOS* command during movement the controller will end in the same physical position it would move to if this command was not sent.

4.6.3. Controller status

Controller tracks its own status and can transfer it in the status structure of the [GETS](#) command. Controller status contains information about performed movement, its result, state of power supply, state of encoder, state of motor windings, digital input-output states, numeric information about position and powering voltage and currents and also error flags.

Movement status

[MoveSts](#) contains:

- Movement flag which is set when controller changes motor position.
- "Target speed reached" flag which is set if current speed is equal to the speed controller should be moving with.
- Backlash compensation flag, which is set during backlash compensation in the final stage of the movement (see [Backlash compensation](#)).

[MvCmdSts](#) contains information about the command being executed. All motor movements are initiated by movement commands to the *MOVE* target position, *MOVR* shift relative to the last target position, *RIGT* movement to the right, *LEFT* movement to the left, smooth stop *SSTP* or fast stop *STOP*, *HOME* home position calibration and *LOFT* forced backlash compensation. Control by buttons, joystick, sync in pulses, etc. is also performed by these commands. For example, joystick calls right and left movement commands during deflection or smooth stop command in central position (see [Joystick control](#)). Current movement command or last command and command status (running/completed) are located in [MvCmdSts](#) variable. If the command is completed then another bit shows its result (successful or not). Unsuccessfully completed command means controller could not reach desired position or backlash compensation could not be performed. The reason for this can be a sudden stop due to limit switches or Alarm state. Initial state of this field contains unknown command and successful completion status.

Motor power supply status

[PWRSts](#) contains information about supply voltage. Windings' status can be:

- Disabled (in this case no voltage is applied).
- Powered by reduced current relative to nominal current (for example if winding current reduction option is used).
- Powered by nominal current.
- Powered by a voltage insufficient to reach nominal current in the windings.

Last status frequently appears with high rotation speeds, because for higher step switching speed one needs higher voltage to ensure current rise in motor winding inductance. Insufficient voltage does not mean the motor won't move, it will merely emit excess noise and its torque will drop (see [Power control](#)).

Encoder status

[EncSts](#) contains information about connected encoder if feedback is disabled (for example for stepper motors). Encoder state can be one of the following:

- Not connected
- Unknown state, when there is not enough data to define encoder state.
- Connected and working.
- Connected and reversed, in this case it is necessary to enable reverse in encoder settings.
- Connected and defective.

The last state is realized when switch signals come to encoder inputs but they don't correspond to the motor rotor movement. State change happens after sufficient statistical data is collected. That's why detection doesn't happen immediately. It is also impossible to define encoder status without movement (see [Operation with encoders](#)).

Motor windings status

[WindSts](#) contains information about windings state. State of each of the two windings is shown separately. They can be:

- Disconnected from controller
- Connected
- Short-circuited
- In an unknown state.

A state with very small resistance and inductance is considered to be a short-circuit. A state with very high load resistance is considered to be disconnected.

Position status.

All data about stage position and speed is reflected in status structure. Fields of primary position ([CurPosition](#), [uStep](#)), secondary position ([EncPosition](#)), speeds ([CurSpeed](#), [uCurSpeed](#)) are used for this. Primary position is counted in steps and microsteps of stepper motor if control without feedback is used. In case of leading encoder mode encoder counts are stored in [CurPosition](#) and [uStep](#) contains 0. Secondary position contains encoder coordinate if no feedback is used for stepper motor, contains steps if a stepper motor with encoder feedback is used and contains 0 if DC motor is used. Speed is always displayed for the primary position and is measured in the same units as the current set speed.

Controller power supply status and temperature.

Status structure reflects:

- Power current (in mA)

- Power voltage (in tens of mV)
- USB current (in mA)
- USB voltage (in tens of mV)
- Microprocessor temperature (tenths of degrees Celsius)

Status flags

There are several types of flags: control command error flags, critical parameter flags, general error flags and state flags. Many flags do not remove themselves and should be reset by the *STOP* command.

Protocol command errors:

- *errc* – Unknown protocol command. This error should not appear if the used software corresponds to the used controller protocol version. Flag can't be removed by itself.
- *errd* – Data integrity command check code is incorrect. This error appears in case of data transfer failure. The flag can't be removed by itself.
- *errv* – One or more values sent in the command could not be applied. It appears when command was received and successfully recognized but transferred data were incorrect or out of range. This error can also mean that necessary operation is impossible because of hardware failure. For example, this error appears if you set microstep mode which is not in supported list or if you set zero steps per motor revolution. The flag can't be removed by itself.

Critical parameter exceeded errors:

- Flag which means that controller is in Alarm state.
- Flag which means that power driver gives overheat signal. The flag is removed by itself depending on [critical parameters settings](#)
- Flag which means that microprocessor temperature is out of acceptable range. The flag is removed by itself depending on [critical parameters settings](#)
- Flag which means that power supply exceeded acceptable value. The flag is removed by itself depending on [critical parameters settings](#)
- Flag which means that power supply voltage is lower than acceptable value. The flag is removed by itself depending on [critical parameters settings](#)
- Flag which means that current drawn from the power unit exceeded acceptable value. The flag is removed by itself depending on [critical parameters settings](#)
- Flag which means that USB voltage exceeded acceptable value. The flag is removed by itself depending on [critical parameters settings](#)
- Flag which means that USB voltage is under acceptable value. The flag is removed by itself depending on [critical parameters settings](#)
- Flag which means that current drawn from the USB exceeded acceptable value. The flag is removed by itself depending on [critical parameters settings](#)
- Flag which means that limit switches are mixed up. The flag can't be removed by itself.

General error flag:

- Flag which means that position control system detected steps counter and position sensor desynchronization. The flag can't be removed by itself (except the case of using position correction).

State flags:

- Presence of connected stage equipped by EEPROM memory.
- Presence of external power supply. Otherwise power supply is internal. Is always set.

Digital signals status.

Controller reflects input and output digital signal status as active state flags or as current logical level. Active state corresponds to one or to zero depending on specific block settings, for example on inverting settings. Flags can be:

- Right limit switch state (one if limit switch is active)
- Left limit switch state (one if limit switch is active)
- Right button state (one if button is pressed)
- Left button state (one if button is pressed)
- 1 if EXTIO pin operates as output. Otherwise - as input.
- EXTIO pin state (1 if state is active on input or on output)
- Hall A sensor state (1 if logical one is on input)
- Hall B sensor state (1 if logical one is on input)
- Hall C sensor state (1 if logical one is on input)
- Magnetic brake state (1 if power supply is applied to brake)
- Complete revolution sensor state (1 if sensor is active)
- Input synchronization pin state (1 if synchronization pin is in active state).
- Output synchronization pin state (1 if synchronization pin is in active state).
- Input encoder A channel state (1 if logical one is on input)
- Input encoder B channel state (1 if logical one is on input)

4.6.4. USB connection autorecovery

This unit is designed to reboot the USB in the event of loss of communication (for example, this may occur in the event of electrostatic discharge or when the USB is disconnected without powering down the controller). The on/off state of this unit is determined by the **USB_BREAK_RECONNECT** flag (see [Critical parameters](#)). If the unit is turned on, it monitors the connection loss on the USB. In the case of communication loss on the USB after 500 ms the firmware reconnects the device and then checks the state of the USB bus. If for a certain time there is no recovery of connection (i.e. data communication), then this unit reconnects the USB again. Thus, in case USB connection is not restored, the controller will continuously reconnect to the USB bus until connection is restored or until the time between reconnection attempts exceeds 1 minute. So, in the case the USB is disconnected without powering down the controller (for example, in the case of motor control with buttons or joystick) controller will remain in USB reconnection mode for about 5 minutes.

Note. USB reconnection mode does not affect other controller functions (for example movement or winding current maintenance) in any way.

To avoid simultaneous reconnect to the USB bus from both the controller and the computer side, the time between the reconnections changes exponentially (see Table 1).

Restart number	timeout, ms
0 (after communication is lost)	500
1	483
2	622
3	802
4	1034
5	1333
6	1718

The status of the unit can be determined by LED flashing frequency. In the case controller is in reconnection mode the LED will flash with a frequency of 10 Hz (see [Operating modes indication](#)).



Warning. Because of the structure of the program unit, as well as USB bus specification, unit doesn't guarantee 100% recovery of the communication with the computer after a static discharge.

Xilab software also tries to reconnect to the controller when it is running. On connection loss, which is defined as "result_noddevice" libximc library call error, Xilab waits for 1000 milliseconds, then attempts to reopen device port. On Windows operating systems Xilab uses WINAPI functions to check if corresponding COM-port device is present. If it is, then after two unsuccessful attempts to reopen it calls libximc ximc_fix_usbser_sys function, which resets the usbser.sys driver to fix the driver error. On Linux or MacOS Xilab simply tries to reopen the device every 1000 ms. After the device is opened Xilab sends several commands to read serial number, firmware version and controller settings which are needed to set up user interface. Libximc library considers device lost (return error code result_noddevice) on critical errors from system calls ReadFile/WriteFile (Windows OS) or read/write (Linux/Mac OS).

4.7. Software compatibility

1. [MicroManager](#)
2. TANGO

4.7.1. Micro-Manager

Preparation

- Install Micro-Manager. It is straightforward procedure and there are usually no problems with setup process.
- Download [libximc-2.7.6](#) library distribution.
- Copy following DLLs from extracted directory `ximc-2.7.6/ximc/win32/` to the Micro-Manager directory: `libximc.dll`, `xiwrapper.dll`, `bindy.dll`
- Install VC++ 2013 Redistributable Package from the extracted file `ximc-2.7.6/ximc/win32/vcredist_x86.exe`
- Connect a power supply to *8SMC4-USB* and set the appropriate voltage for motors in your stage. Turn a power supply on.
- You need XiLab to check your *8SMC4-USB* controllers and set it. XiLab version depends on the controller firmware version. You can download XiLab and update controller's firmware at this page: <https://en.xisupport.com/projects/enxisupport/wiki/Software>.
- Connect 8SMC4-USB controllers to computer via USB and open them in XiLab software. Click *Restore from file...* in *Settings...* window of XiLab and choose appropriate profile for your stage. Click *Save to flash*. For additional information visit: https://en.xisupport.com/projects/enxisupport/wiki/XILab_application_User's_guide.

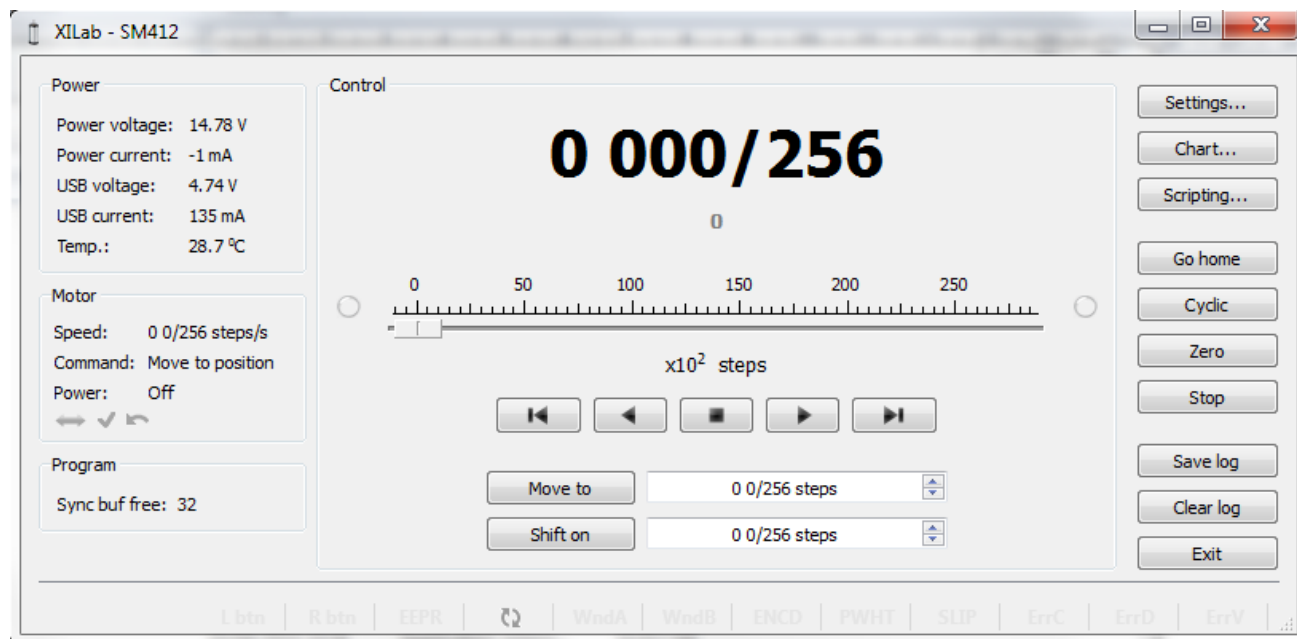

Getting started with Micro-Manager

Run Micro-Manager

Note. When installing the Micro-Manager in *C:\Program Files* access to configuration files is limited and you need to have administrator privileges. To start an application as administrator right click by its icon and choose *Run as administrator*.

- Run Micro-Manager from the shortcut at your desktop or start `ImageJ.exe` application from installation directory. First time it will greet you and suggest to type some information about yourself.
- The next window contains drop-down list with configuration files. Choose *None*.

Configure hardware

- In the main window choose *Tools* → *Hardware configuration wizard*.

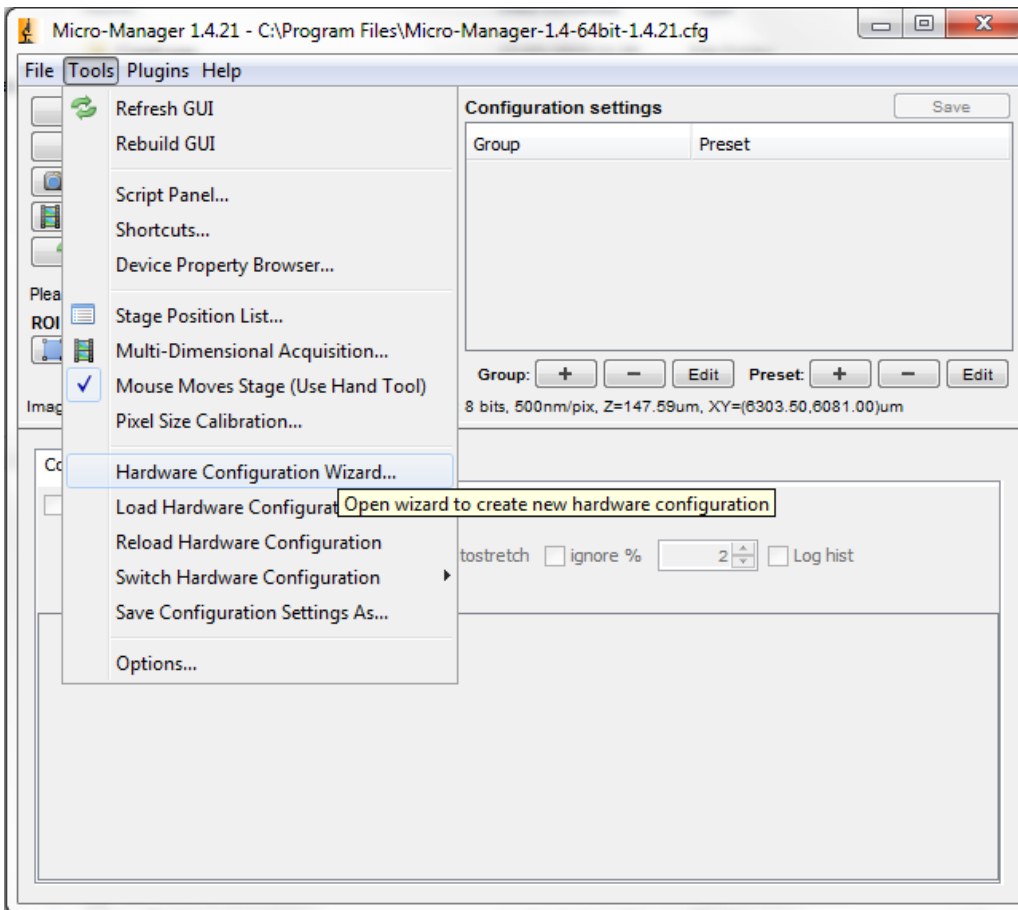

The process of hardware configuration consists of 6 steps:

1. At start, choose "Create new configuration" and click "Next".

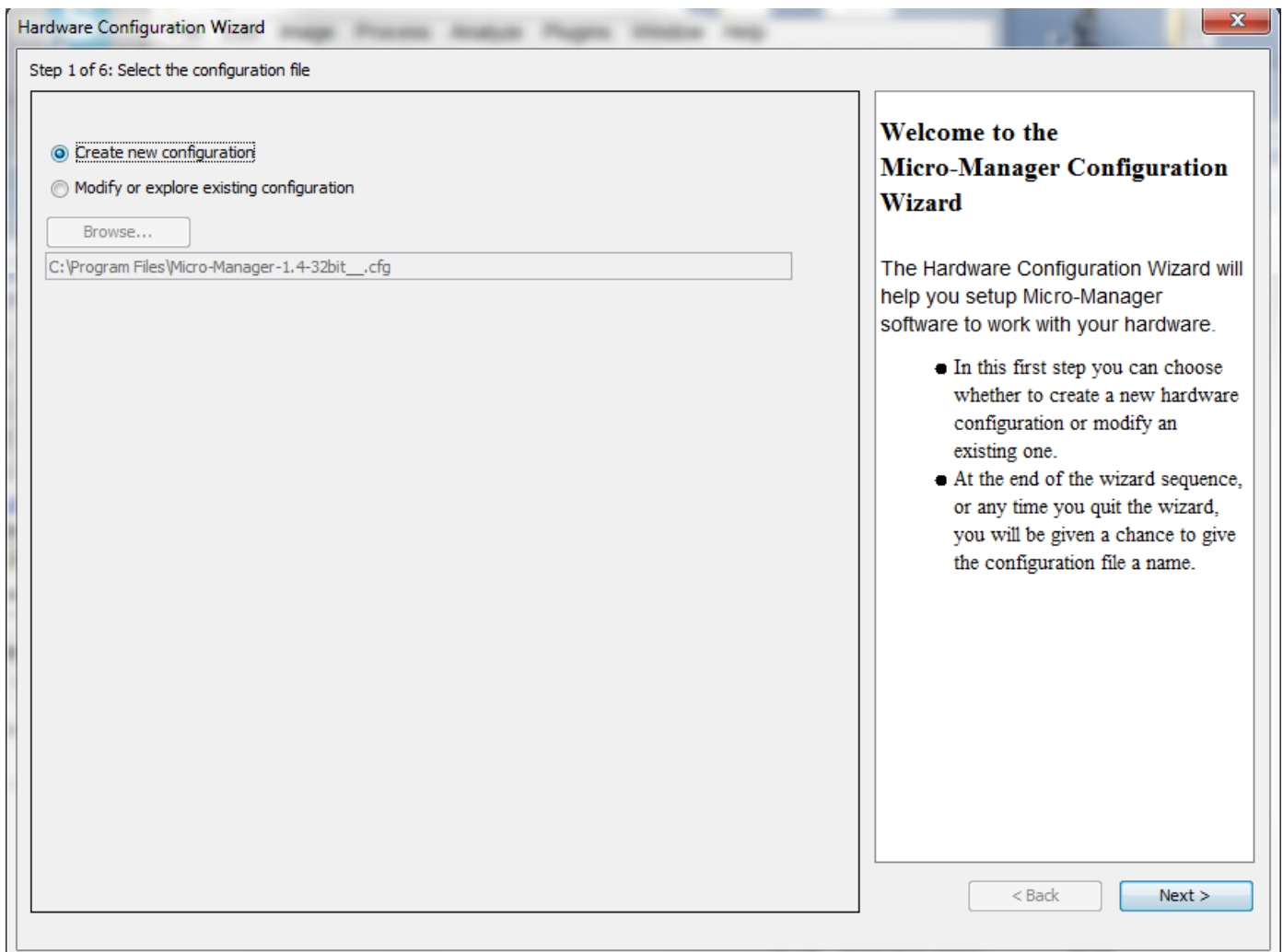

2. At the second step Micro-Manager prompts you to add hardware. If you want to use MicroManager with *8SMC4-USB* motor controller choose *Standa8SMC4* folder in down window with available devices. There are two drivers: *Standa8SMC4Z* for motor controller with one axis and *Standa8SMC4XY* for controller with 2 axes. When you select one of them, a dialog box with properties will appear.

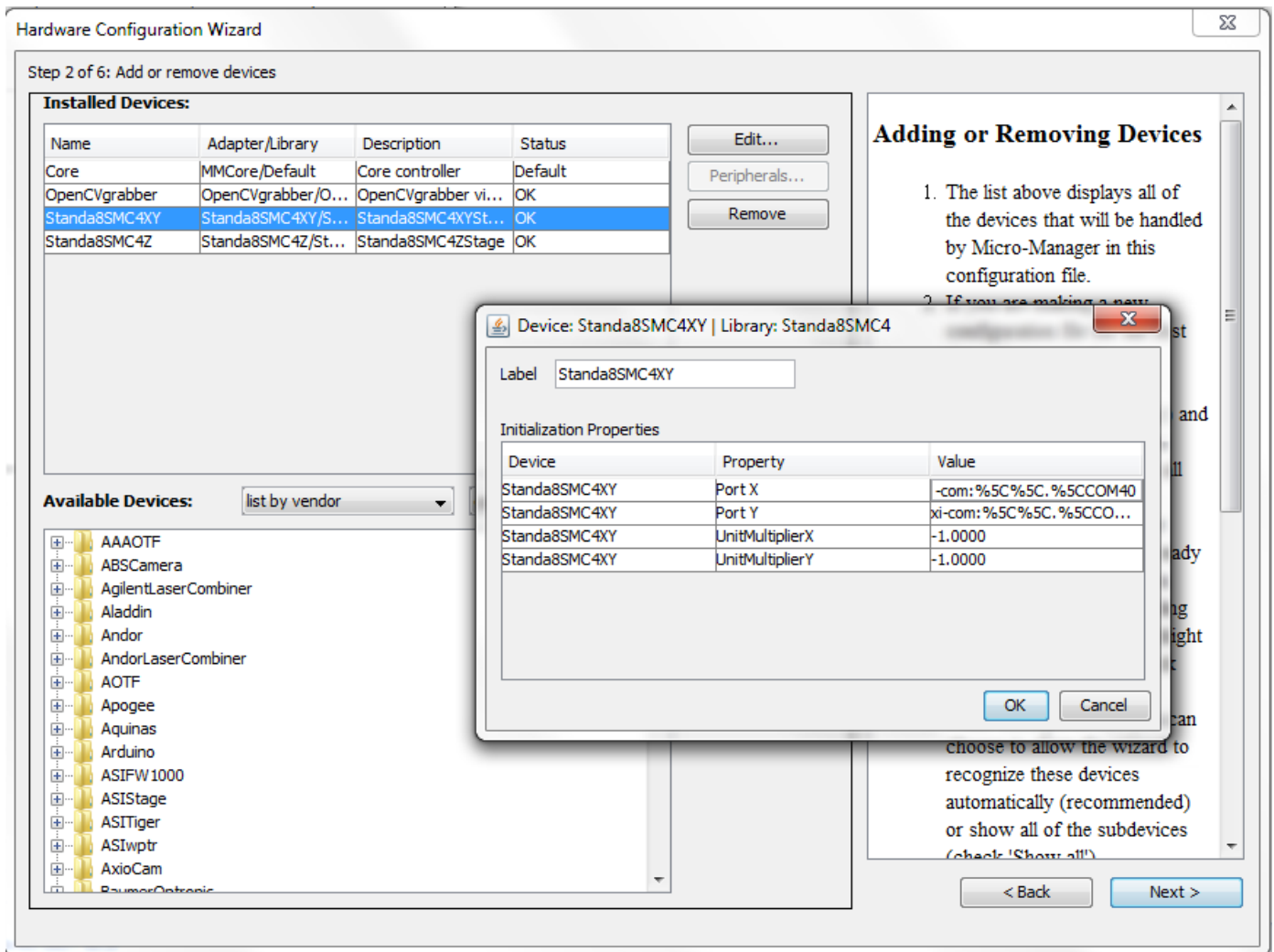

3. In the *Value* column type the COM port number for motor controller in the next format:

```
xi-com:%5C%5C.%5CCOMn
```

Trailing letter *n* is a number of corresponding COM port (look at the screenshot above). You can find it in Xilab or in *Device Manager* → *Ports*. Click *Ok*. *Unit Multiplier X/Y* fields are leaved with default values. These values allow you to set stage speed.

4. For *Standa8SMC4Z* you should type COM port and Unit Multiplier too. Z axis is usually used as a focusing stage.

5. Camera is added in the same way. You need to know correct driver name for your camera. *OpenCVGrabber* driver may be used for any USB camera. Choose *OpenCVGrabber* folder in *Available Devices*. The next window will appear. Click *Ok*.

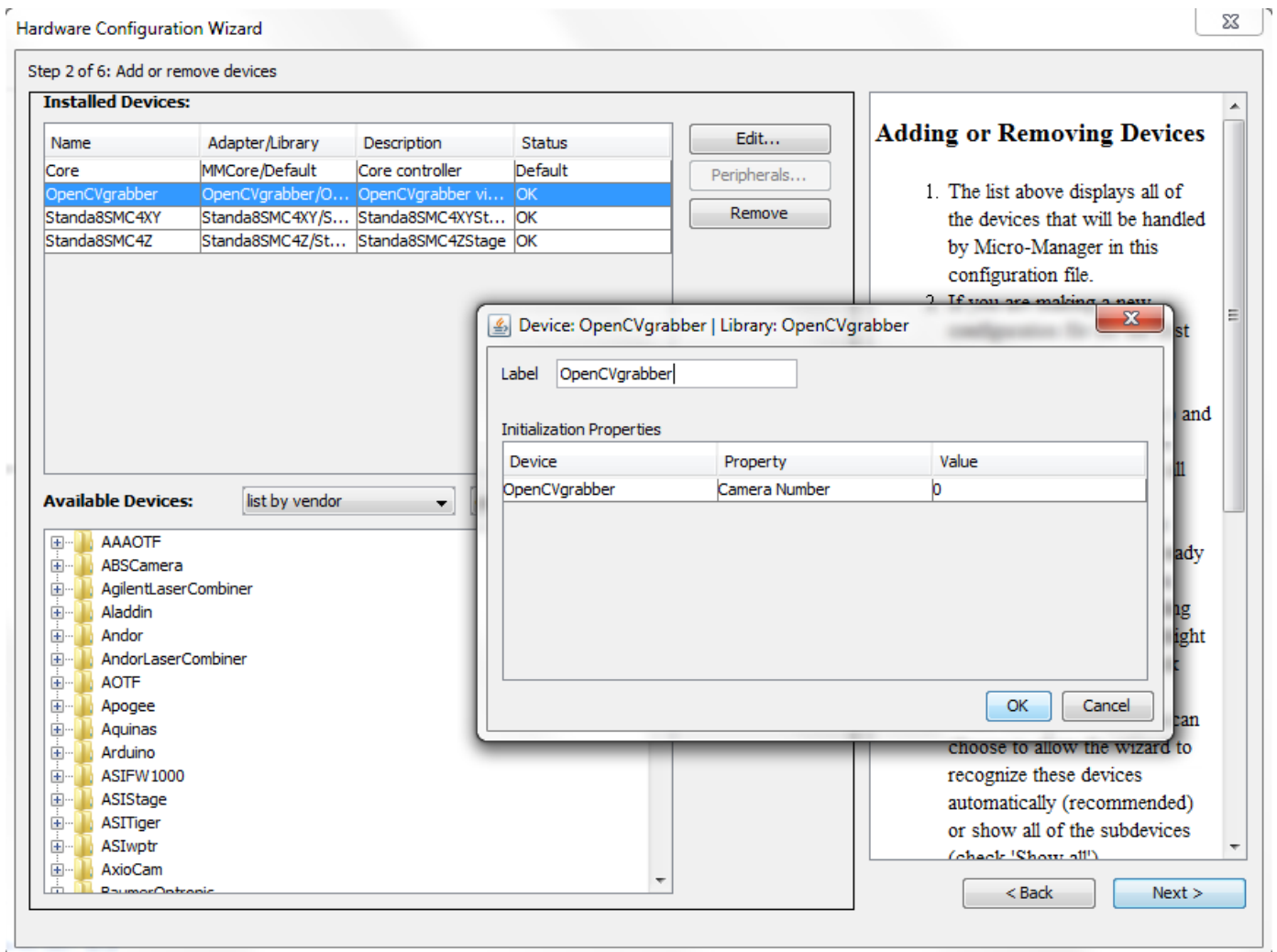

6. Click *Next* continue and *Finish* in the last step.

The system configuration is finished.

Device usage

We have installed and configured Micro-Manager and can check how does it work.

1. Set the pixel size parameter in *Tools* → *Pixel Size Calibration...*. There are you should type the pixel size value and mark parameters that Micro-Manager should consider. Click *New* to create new pixel size. In appeared window mark resolution of your camera (with *OpenCVGrabber* it is *OpenCVGrabber - Resolution* parameter) and type pixel size (in um). If you want to calculate pixel size parameter you need to know image size from microscope, its resolution and displacement (from screw pitch) for you stage.
2. Modify *UnitMultiplierX* and *UnitMultiplierY* (*Tools* → *Hardware Configuration Wizard* → select "Modify or explore the existing configuration" → Click "Next" → Double click to "Standa8SMC4XY" in *Installed Device window*). It is needed for correct conversion from stage movement distance to pixel size value change.
3. Choose *Tools* -> *Stage Position List...*. Click *Set Origin* to set zero of your stage coordinate system. Then, in the main window click *Live*. Choose *Scrolling Tool* (like a hand) in the *ImageJ* window. Make sure that cursor looks like a hand on the screen. Click the windows with the video from camera. Now you can control your stage by keyboard (arrow keys to control XY axis and U,J buttons to control Z axis).
4. You can scroll an image from a camera with the mouse cursor. Click *Tools* → *Mouse Moves Stage (Use Hand Tool)*. Now click video window and drag it in the desired direction. Stage will move in the same direction. Double click will allow you to center the view on the chosen point in the image.

Note. For example you set the pixel size is equal to 1um. And *UnitMultiplierX/Y* is equals to 1.0000. With 8MTF stage table one pixel shift corresponds to 12.5um. If we will set *UnitMultiplierX/Y* to 12.5 than movement at one pixel will corresponds to 1um. **

Note. You may decrease *UnitMultiplier* if the stage speed is low and increase it if the stage speed is very high.

4.7.2. TANGO

Overview



Our controllers provide TANGO interface!

The TANGO control system is a free open source device-oriented controls toolkit for managing any kind of hardware or software and building SCADA systems. It is used for controlling synchrotrons, lasers, physics experiments in over 20 sites. It is being actively developed by a consortium of research institutes.

TANGO is based on the concept of Devices. Devices implement object oriented and service oriented approaches to software architecture. The Device model in TANGO implements commands/methods, attributes/data fields and properties for configuring Devices. In TANGO all control objects are Devices and hardware access is managed in a process called a Device Server.

The Device Server contains Devices belonging to different Device Classes which implement the hardware access. At Device Server startup time Devices (instances of Device Classes) are created which then represent logical instances of hardware in the control system. Clients import the Devices via a TANGO Database Server and send requests to the devices using zeromq and CORBA protocols.

Standa 8SMC4-USB controllers are compatible with TANGO 8.1 system via custom device server implementation and can be used in two scenarios:

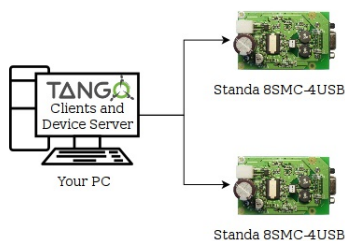

Using TANGO interface via device server directly on your PC

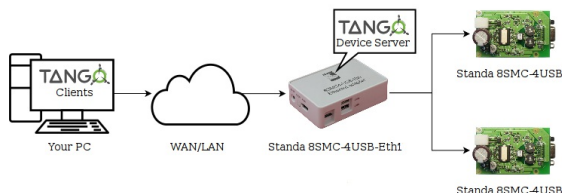

Using TANGO interface via **Standa 8SMC4-USB-Eth1** adapter device

Declaring the device, configuring and starting device server



Warning. The device server for **Standa 8SMC4-USB** was developed and tested with TANGO 8.1 version. It *should* work with any TANGO version greater than or equal to 7 due to backward and forward compatibility in the API but hasn't been verified yet.

First of all you should declare the device in your local TANGO Database Server. The easiest way to do it is via [Jive](#):

1. Connect to your local TANGO control system ([Edit](#) -> [Change Tango Host](#)).
2. Start registration wizard ([Tools](#) -> [Server Wizard](#)).

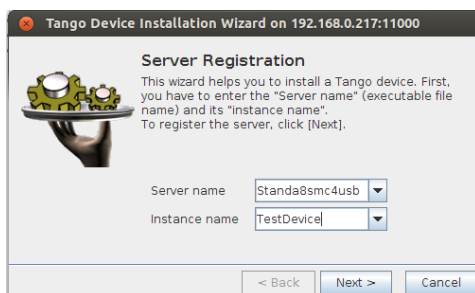

Jive server wizard dialog

3. Enter "Standa8smc4usb" in [Server Name](#) field. [Instance name](#) can be arbitrary word containing alphanumeric symbols only (e.g.

"TestDevice").

4. Press next - you should see Start the server window. Now it's time to actually start the device server.
 - If you have **Standa 8SMC4-USB-Eth1** and want to use its inbuilt TANGO support you should open [administration interface](#) and do configuration and/or perform startup from there.

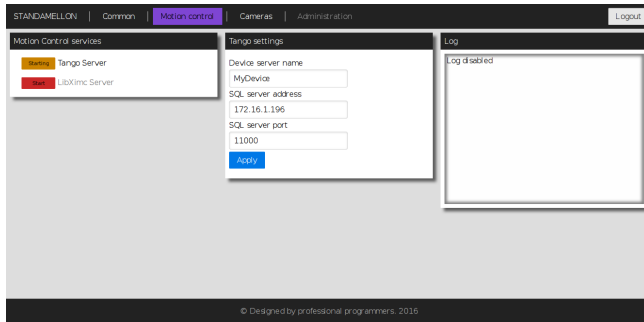

TANGO service configuration page in the [administration interface](#)

- Otherwise if you're going to use TANGO device server directly, you have to compile it for your target platform manually from [the source](#). The resulting `Standa8smc4usb` executable should be started with previously entered in "Jive" instance name as its' first argument (e.g. "TestDevice"). If everything is fine you'll see Ready to accept requests in standard output stream.

Note. Device server instance name entered in Jive must match the name specified during device server instance startup (both manually via executable and from [administration interface](#)).

Note. Before starting "Standa8smc4usb" device server make sure that "TANGO_HOST" environment variable points to your local TANGO Database Server e.g. "192.168.0.172:11000".

5. Go back to Jive Start the server window and press next button.
6. In the Class Selection window choose `Standa8scm4usb` class and press Declare device button.
7. Enter TANGO specification compliant Device name (e.g. "a/b/c") and press next.
8. The next step requires entering SerialNumber. It can be obtained either from Common section in the [administration interface](#) if you're using **Standa 8SMC4-USB-Eth1** device, or via [XiLab](#) ([Settings](#) -> [About Device](#) -> [Serial number](#)).

Note. XiLab may also be used to obtain serial number of the controller connected to **Standa 8SMC4-USB-Eth1** device but LibXimc motion control service has to be enabled in administration panel for this to work. For more information please refer to [XiLab documentation](#).

9. After that CalibrationRatio and CalibrationUnits parameters should be set. Theirs purpose is to replace internal controller coordinates with units familiar to the user and should be treated as " $1 \text{ step} = \text{CalibrationRatio} \text{ CalibrationUnits}$ " formula. If you don't need calibration, set these parameters to "1.0" and empty string respectively.
10. Device declaration procedure (previous 3 steps) should be repeated for each connected controller you want to access via TANGO interface.

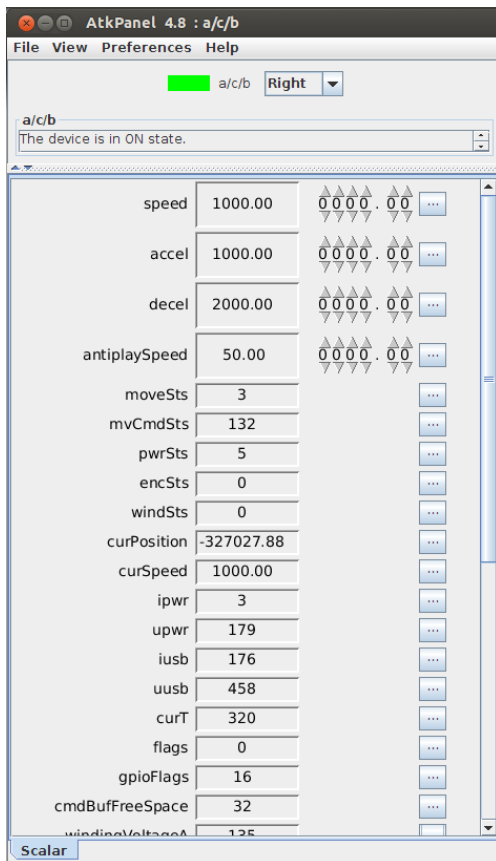

Default ATK panel for controller exposed via TANGO

After that any exported controller is available for configuration and control through TANGO interface making it blend seamlessly with your existing infrastructure! For more info please refer to official TANGO [documentation](#).

5. XILab application User's guide

1. About XILab
2. Main windows of the XILab application
 1. XILab Start window
 2. XILab Main window in single-axis control mode
 3. XILab Main window in multi-axis control mode
 4. Application Settings
 5. Charts
 6. Scripts
 7. XILab Log
3. Controller Settings
 1. Settings of kinematics (Stepper motor)
 2. Motion range and limit switches
 3. Critical board ratings
 4. Power consumption settings
 5. Home position settings
 6. Synchronization settings
 7. Brake settings
 8. Position control
 9. Settings of external control devices
 10. UART settings
 11. General purpose input-output settings
 12. Motor type settings
 13. Settings of kinematics (DC motor)
 14. Settings of PID control loops
 15. About controller
4. XILab application settings
 1. XILab general settings
 2. General motor settings
 3. Attenuator settings
 4. Cyclical motion settings
 5. Log settings
 6. Charts general settings
 7. Charts customization
 8. User units settings
 9. About the application
5. Positioner specifications
 1. Positioner name
 2. Positioner general characteristics
 3. Motor characteristics
 4. Encoder specifications
 5. Hall sensor characteristics
 6. Reducing gear specifications
 7. Accessories specifications
6. Correct shutdown
7. Working over network
8. XILab installation
 1. Installation on Windows
 1. Installation on Windows XP
 2. Installation on Windows 7
 3. Installation on Windows 8
 2. Installation on Linux
 3. Installation on MacOS

5.1. About XILab

XILab features a user-friendly graphical interface, which is designed for stages control, diagnostic and fine tuning of the motors driven by the controllers. XILab allows quick adjustment of connected stage by loading of previously prepared configuration files. The control process can be automated with script language that can be used either directly or to speed up the process of customized control program development. XiLab supports multiaxial mode and multidimensional control scripts. It is possible to output the data about controller and motor status in form of charts and save them to a file, or export tabular data for external processing. The software is compatible with Windows XP SP3, Windows Vista, Windows 7, MacOS X and Linux operating systems. Depending on the OS of your computer, appearance of some windows may vary.

[Here](#) you can find the Quick Installation Guide for the application. This chapter provides a detailed manual for the XILab software.

5.2. Main windows of the XILab application

1. [XILab Start window](#)
2. [XILab Main window in single-axis control mode](#)
3. [XILab Main window in multi-axis control mode](#)
4. [Application Settings](#)
5. [Charts](#)
6. [Scripts](#)
7. [XILab Log](#)

5.2.1. XILab Start window

When started, XILab opens a controllers detection window. By means of libximc library, XILab queries controllers connected to the system and displays a list of found and successfully identified controllers.



XILab Start Window, 0 controllers found



XILab Start Window, 1 controller found

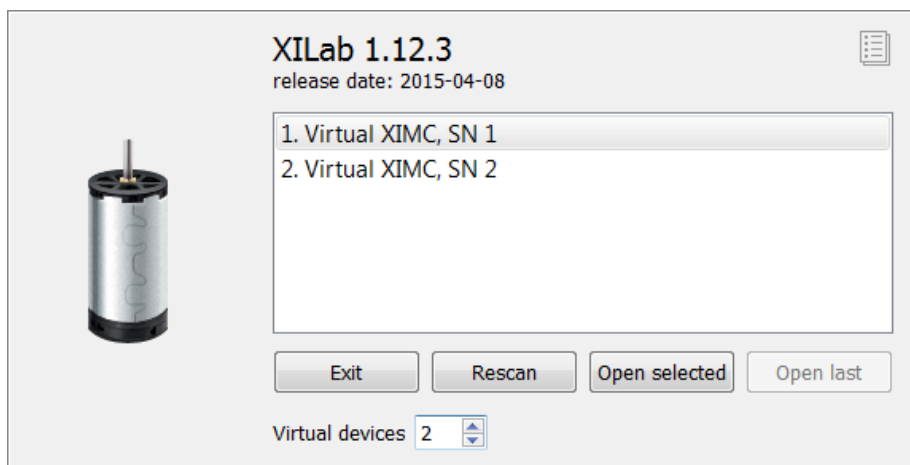

XILab Start Window, 2 controllers found

The list of found controllers is displayed on the start screen. Here you can select one or more controllers and open them using the [Open selected](#) button. If one controller is chosen, then [XILab Main window in single-axis control mode](#) will be opened, if more than one controller is chosen the [XILab Main window in multi-axis control mode](#) window will be opened. You could repeat the search by clicking the [Rescan](#) button or exit the program by clicking [Exit](#). If the [Open last](#) button is active it means that all the controllers that had been opened in the previous run of XILab were found. Clicking the [Open last](#) button will then open the last saved configuration.

XILab can work with virtual XIMC controllers, which support the request-response protocol of a real controller. Virtual controllers may be useful for testing and getting used to the XILab interface, if no real hardware controllers are connected to the system. The [Virtual devices](#) field contains the number of virtual controllers which will appear in the list of available controllers after you press the [Rescan](#) button or restart the XILab.

Note: Since the libximc library opens XIMC devices in the exclusive access mode, when you start subsequent copies of XILab application, only free controllers will be found and available for selection.

5.2.2. XILab Main window in single-axis control mode

5.2.2. XILab Main window in single-axis control mode

- Motion Control Unit
 - Movement without specifying the final position
 - Movement to the target point
 - Target position for motion commands
- Attenuator Control Unit
- Controller and motor status
 - Controller Power Supply
 - Motor status
 - Program status
- Group of application control buttons
- Status bar

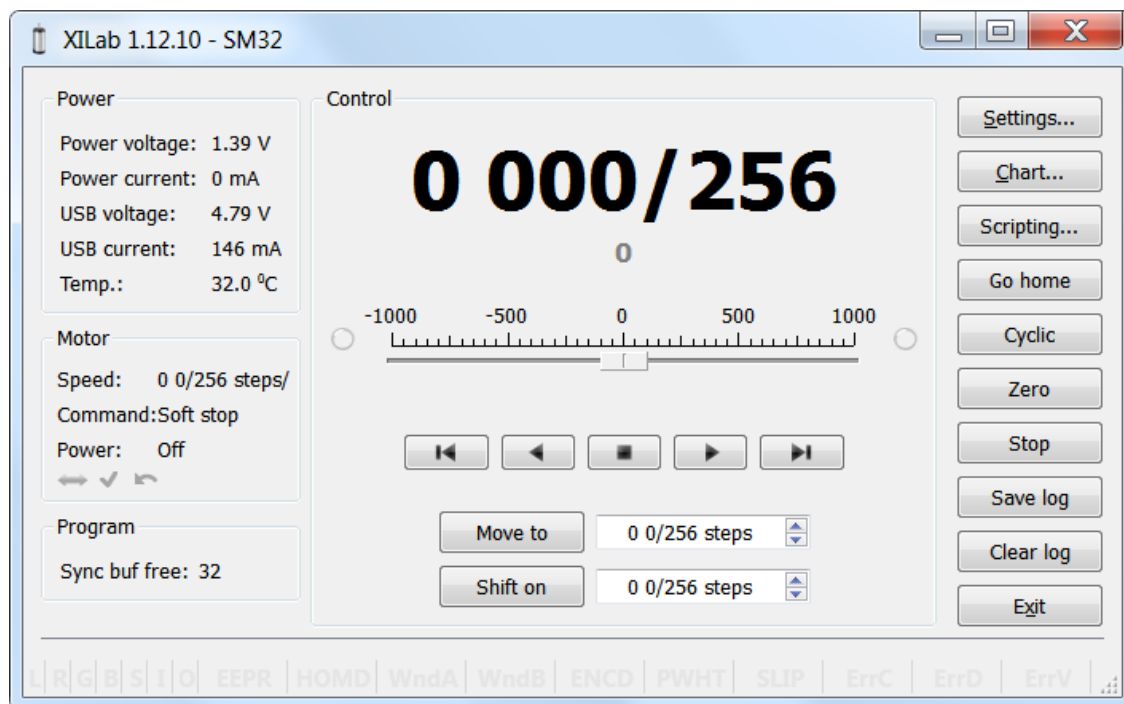

XILab Main Window in General Motor mode

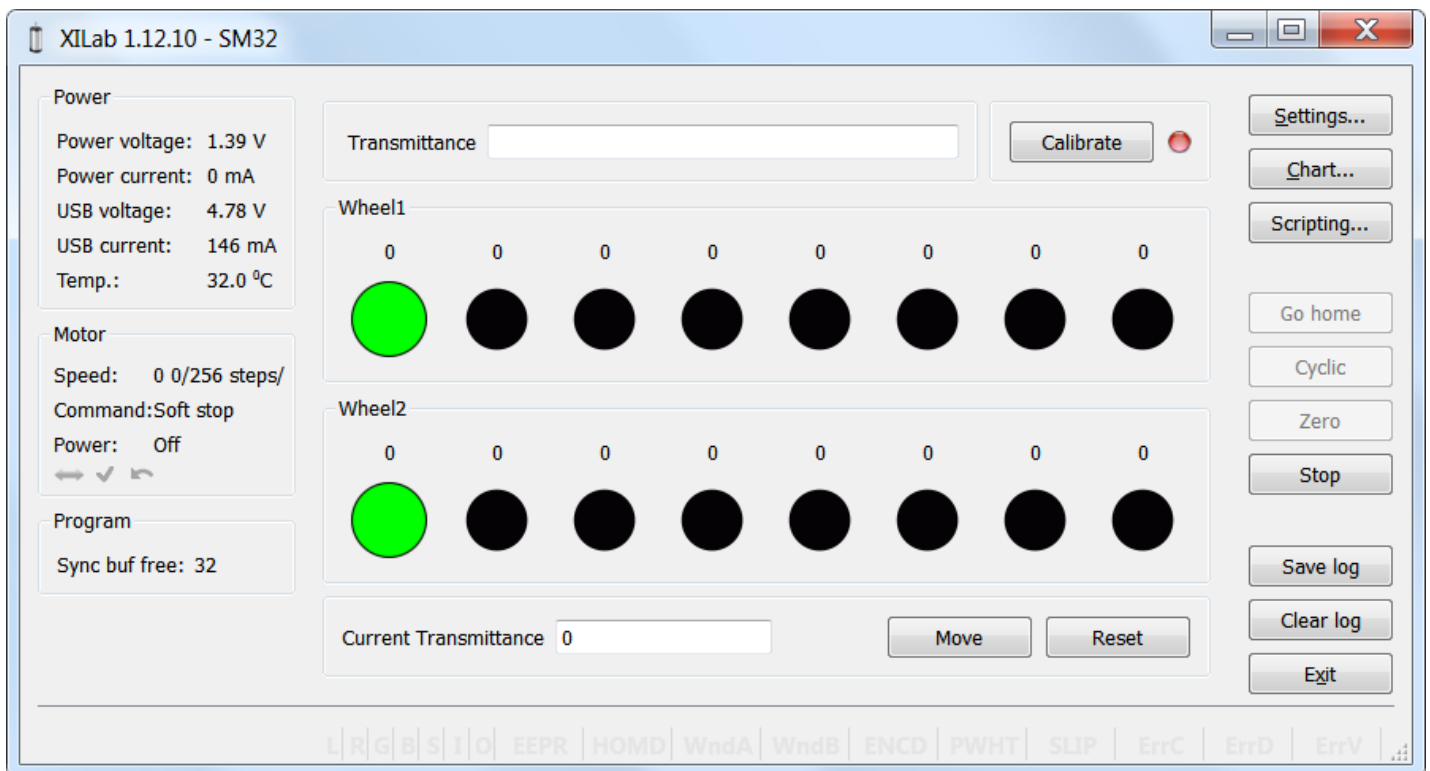

XILab Main Window in Attenuator mode

In the left part of the window in **Power** and **Motor** groups of parameters status of the controller and the motor is available. In the central part of the window there is the **Control** group, containing the elements of motor motion control. On the right there is a group of buttons to control the application as a whole. At the bottom there is a **log**, which is hidden as the window is resized to its minimum size and a status bar. Below we consider these groups in more detail.

Motion Control Unit



Control Unit

In the central part of the block there is an indicator of the current position. Below it, in case the encoder is enabled, is located an encoder position indicator. In the closed loop mode (see [Operation with encoders](#) section) the main and the secondary indicators swap their places.

Below is the **Control** unit, containing the elements of motor motion control. Let us examine them in greater detail:

Movement without specifying the final position



Movement control buttons

- The buttons **Left**, **Stop** and **Right** trigger movement to the left without specifying the final position, **stop with deceleration** any previously started movement, and start the movement to the right without specifying the final position, respectively.

- Button Left to the border will make the motor rotate to the left border of the slider. Right to the border, respectively, will do it to the right edge of the slider.
- When you press and hold the keyboard buttons Right or Left and the slider block has input focus, the movement starts in the direction of increasing or decreasing coordinate. When you release the button the movement stop as if the Stop button on the main window have been pressed.

Movement to the target point

The image shows a control panel with two rows. The first row has a button labeled 'Move to' followed by a text input field containing '0' and a dropdown menu showing '0/256 steps'. The second row has a button labeled 'Shift on' followed by a text input field containing '0' and a dropdown menu showing '0/256 steps'.

Movement control to the given point

- Move to button starts the process of moving to the given position.
- Shift on button starts the process of shift to a given distance from the target position.

Target position for motion commands

Commands Move to and Shift on use the target position to calculate the movement. The target position is changed by the following commands:

Move to <value>
Target position = <value>

Shift on <offset>
Target position = target position + <offset>

Zero (provided there is no movement at the moment of sending the command)
Target position = 0

Commands Stop, Left, Right, Left up to the border and Right up to the border do not alter the target position.

Attenuator Control Unit

The image shows a control panel for an attenuator. At the top, there is a 'Transmittance' input field and a 'Calibrate' button with a red indicator light. Below this are two sections, 'Wheel1' and 'Wheel2'. Each section contains a row of eight circular buttons representing filters. The values above the buttons are: Wheel1 (1, 0, 0.9, 0.5, 0.1, 0.01, 0.001, 0.0001) and Wheel2 (1, 0, 0.8, 0.3, 0.03, 0.003, 0.0003, 3e-05). The '1' filter in both sections is highlighted in green. At the bottom, there is a 'Current Transmittance' input field showing '1', and 'Move' and 'Reset' buttons.

Attenuator Control Unit

At the top of the attenuator control block a Transmittance window and a Calibrate button are located. Transmittance window contains a control to select desired transmittance coefficient. Calibrate button does manual calibration, or location of the initial position, of the attenuator - first it initiates one revolution of attenuator with current controller settings to determine relative position of attenuator wheels and then does Automatic Home position calibration. Calibrate button is optional - if the attenuator did not perform the calibration or it was reset, for example by pressing Cancel during movement, calibration will be performed before the next movement automatically.

Attenuator has one or two wheels, each wheel contains 8 optical filters. Below these filters are visualized as bars with circles. Below a Current Transmittance window is located. This window contains transmittance coefficient which is the closest to desired one that can be achieved with the current filters.

Move button performs movement toward the filters corresponding to the Current Transmittance, that is, the highlighted ones.

Reset button deactivates all filters.

Controller and motor status

Power	
Source:	External
Power voltage:	1.39 V
Power current:	0 mA
USB voltage:	4.84 V
USB current:	144 mA
Temp.:	33.3 °C

Motor	
Speed:	0 0/256 st/s
Command:	Soft stop
Power:	Off

Controller Power Supply

Power group of parameters contains the following indicators:

- Source - source of power supply for controller. The controller may be powered by USB or by External power source.
- Power voltage - voltage supplied to the power module.
- Power current - current consumption of the power module.
- USB voltage - voltage on USB connector.
- USB current - current consumed by the controller via USB
- Temp. - Temperature of the controller processor.

If the color of the indicator Power voltage changes to blue or red, it shows that voltage power supply exceeds the allowed value range over the acceptable value, which is defined in the [Critical board ratings](#). In this case, the controller switches to Alarm state. It is possible to quit the Alarm state after terminating of the events that caused Alarm, provided that the flag Sticky Alarm is not set. If the flag Sticky Alarm is on, use the Stop button to quit the Alarm state.

If color of the indicator Power current turns red, it shows that the current consumed by the controller from the power supply is over the acceptable value, which is defined in the [Critical board ratings](#). In this case, the controller switches to Alarm state. It is possible to quit the Alarm state after terminating of the events that caused Alarm, provided that the flag Sticky Alarm is not set. If the flag Sticky Alarm is on, use the Stop button to quit the Alarm state.

If the color of the indicator USB voltage turns blue or red, it shows that the USB voltage goes out of the allowed value range towards lower and higher voltage respectively. In this case, the controller switches to Alarm state. It is possible to quit the Alarm state after terminating of the events that caused Alarm, provided that the flag Sticky Alarm is not set. If the flag Sticky Alarm is on, use the Stop button to quit the Alarm state.

If the color of the indicator USB current turns red, it shows that the USB current supply exceeds the acceptable value, which is defined in the [Critical board ratings](#). In this case, the controller switches to Alarm state. It is possible to quit the Alarm state after terminating of the events that caused Alarm, provided that the flag Sticky Alarm is not set. If the flag Sticky Alarm is on, use the Stop button to quit the Alarm state.

If the color of the indicator Temp. turns red, it shows that the temperature of the controller board exceeds the acceptable value, which is defined in the [Critical board ratings](#). In this case, the controller switches to Alarm state. It is possible to quit the Alarm state after terminating of the events that caused Alarm, provided that the flag Sticky Alarm is not set. If the flag Sticky Alarm is on, use the Stop button to quit the Alarm state.

Motor status

Motor group of parameters contains the following indicators:

- Speed - rotation speed of the motor.
- Command - the last performing (bold font) or executed (plain font) controller command. Controller command appears in black if the flag of the motion error MVCMD_ERROR is not set, in red otherwise. Can be one of the following options:
 - Move to position - move to the set position
 - Shift on offset - offset for a predetermined distance
 - Move left - move left
 - Move right - move right
 - Stop - stop
 - Homing - find the home position
 - Loft - backlash compensation
 - Soft stop - smooth stop
 - Unknown - unknown command (it may appear immediately after the controller starts)
- Power - state of stepper motor power supply. Can be one of the following options:
 - Off - motor winding is disconnected and not controlled by the driver,
 - Short - winding is short-circuited through the driver,
 - Norm - winding is powered with nominal current,
 - Reduc - winding is deliberately powered with reduced current relatively to operational one to reduce the power consumption,
 - Max - winding is powered with maximum available current, which a scheme with a given voltage supply can output.

Program status

Program group of parameters contains the following indicators:

- [Sync buf free](#) - free slots in the syncin command buffer (see description of [ASIA](#) command).

Group of application control buttons

- [Settings...](#) button opens controller settings, see [Application Settings](#).
- [Chart...](#) button opens a window with charts, see [Charts](#).
- [Scripting...](#) button opens scripting window, see [Scripts](#).
- [Go home](#) button searches for the home position, see [Home position settings](#).

- [Cyclic](#) button turns on the cyclic motion, see [Cyclical motion settings](#).
- [Zero](#) button resets the current position of the motor and the encoder value.
- [Stop](#) button sends the command of [emergency stop](#), resets the Alarm state, clears the command buffer for synchronous motion and stops a script if it is running.

- [Save log](#) button saves the contents of the log to a file in [CSV](#) format (opens a file selection dialog window).
- [Clear log](#) button clears the contents of the log.
- [Exit](#) button performs safe shutdown, see [Correct shutdown](#).

Status bar

Status bar contains current controller status indicators. From left to right these are 7 flags,

- L - Left button state.
- R - Right button state.
- G - State of external GPIO pin.
- B - State of brake pin.
- S - State or revolution sensor pin.
- I - State of sync in pin.
- O - State of sync out pin.

and separate indicators

- EEPR - EEPROM is connected.
- HOMD - Controller is in "homed" state (calibration performed).
- WndA - Winding A state.
- WndB - Winding B state.
- ENCD - Encoder state (none/active/inverted/failed).
- PWHT - Power driver overheat.
- SLIP - Motor slip detected.
- ErrC - Command error encountered.
- ErrD - Data integrity error encountered.
- ErrV - Value error encountered.

5.2.3. XILab Main window in multi-axis control mode

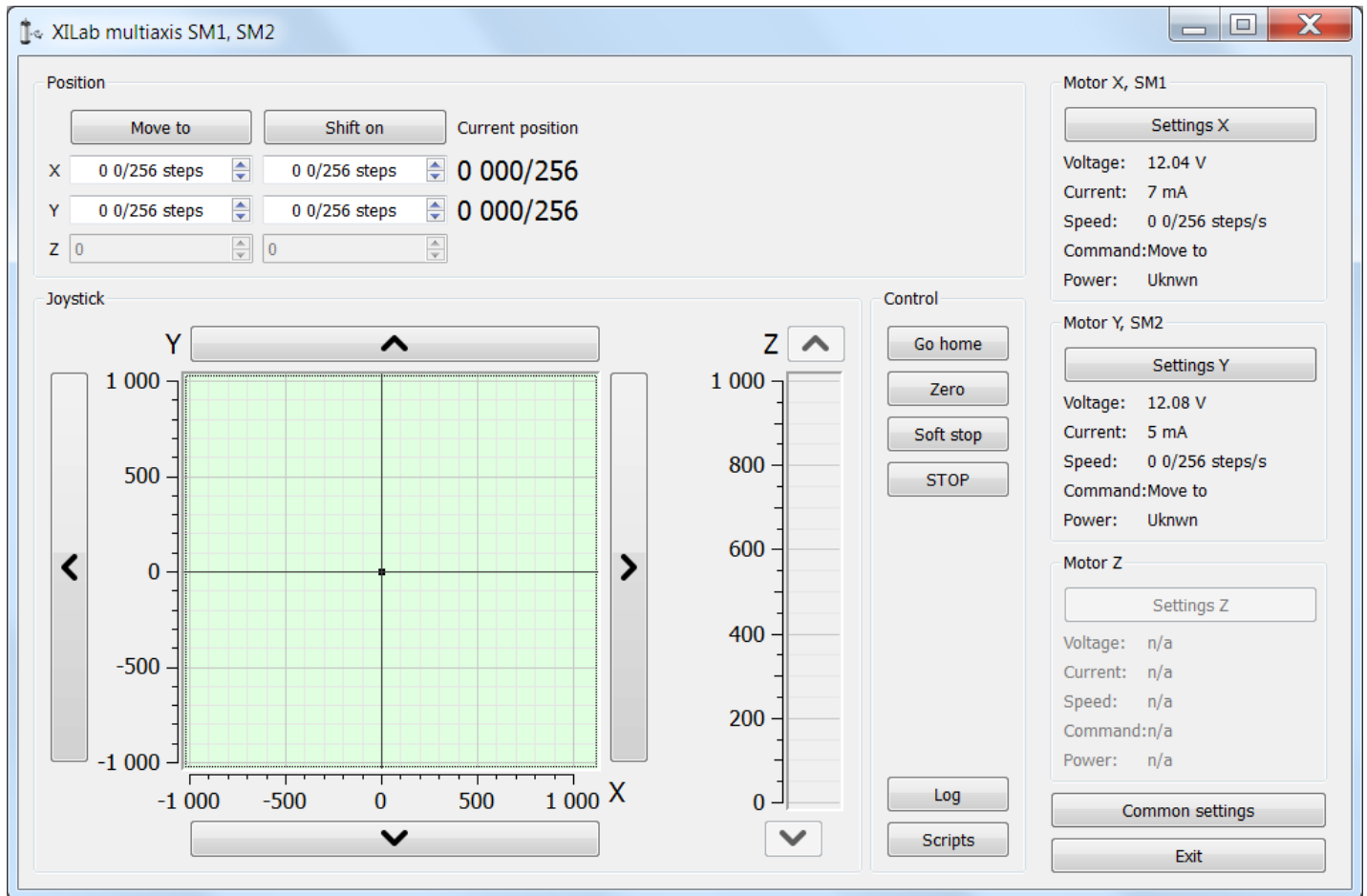

XILab Main window

In the top left part of the screen in the **Position** parameter group there are indicators of the current position. In the bottom left part of the window there is the **Joystick** and **Control** blocks, which are a graphical control element for several axes and a button block respectively. In the top right part, in the **Motor** blocks data on the current status of controllers and connected motors is located. In the bottom right part of the window there is a group of buttons for application control as a whole. Let us consider these groups in more detail.

Motion control block

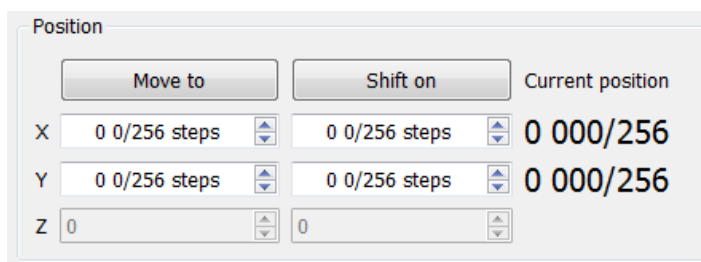

Motion control block

In the Current position column indicators of the current position in steps or calibrated units (see below) for the axes X, Y and Z (from left to right) are located. The Move to button performs movement to the coordinate given by the controls of its column, and the Shift on button performs shift on relative offset for a predefined distance. If one of the controllers is temporarily absent or disabled, the corresponding line becomes grayed out.

Virtual joystick block

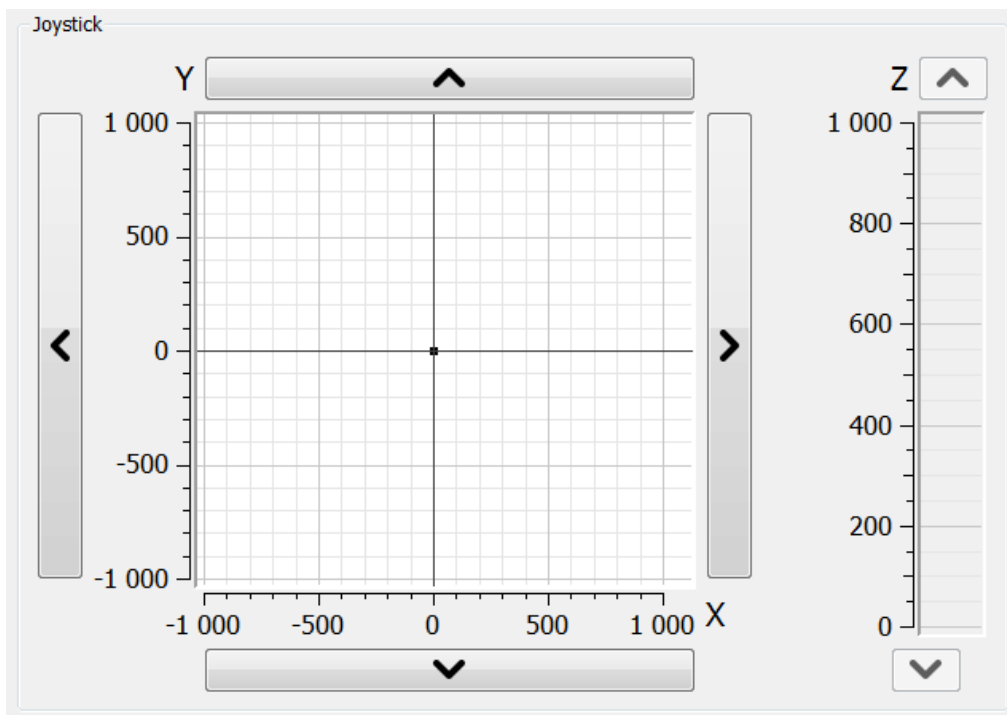

Virtual joystick block

In this block, the current coordinate of the controllers is visualized as a dot with two lines on the plane for X-Y axes and the line for the Z axis.

There are several possible ways to control movement of the controllers:

- When you click anywhere on the X-Y plane or in the Z column, the corresponding controller or controllers start to move to the selected coordinate in accordance to its own movement settings.
- When you press and hold the screen buttons with up, down, left and right arrows, the corresponding axis starts to move in that direction. The movement **stops with deceleration** when you release the button (soft stop command is sent).
- When you press and hold the keyboard buttons Right, Left, Up, Down, PageUp or PageDown when the joystick block has input focus, the axis X, Y or Z, respectively, starts to move in the direction of increasing or decreasing coordinate. The movement **stops with deceleration** when you release the button (soft stop command is sent). On receiving input focus the widget background color changes from white to light-green.

The scales of the axes are set in "Slider settings" on [Program configuration](#) page in Settings window separately for each controller. If [user units](#) are being used, then the corresponding axis scale is measured in these units. If the position read from any controller is out of its axis range, then the corresponding indicator will not appear on the screen.

Control block



Control block

The [Go home](#) button searches for the home position independently for each of the controllers; see [Home position settings](#).

The [Zero](#) button resets the current position of the motor and value of the encoder for each controller.

The [Soft stop](#) button executes a soft stop for each of the controllers.

The [STOP](#) button sends an [emergency stop](#) command to each controller, resets their Alarm statuses, clears their command buffers for synchronous motion and stops a script if one is running.

The [Log](#) button opens a window with log information. Here you can find diagnostic information (errors, warnings, informational messages) from XiLab, libximc and script sources.

The [Scripts](#) button opens a scripting window, see [Scripts](#).

Block of status indicators for controllers and motors

Motor X, SM1

Voltage: 12.04 V
 Current: 7 mA
 Speed: 0 0/256 steps/s
 Command: Move to
 Power: Uknwn

Motor Y, SM2

Voltage: 12.08 V
 Current: 5 mA
 Speed: 0 0/256 steps/s
 Command: Move to
 Power: Uknwn

Motor Z

Voltage: n/a
 Current: n/a
 Speed: n/a
 Command: n/a
 Power: n/a

Block of status indicators for controllers and motors

Here are the three blocks of indicators of controllers and motors for axes X, Y and Z. In the title of the block the serial number of corresponding controller is displayed. Each block contains the following indicators:

- Voltage - the voltage at the power section of the motor.
- Current - current power consumption of the motor.
- Speed - current speed of the motor.
- Command - the last command of the controller that was executed, or is being executed.
- Power - the state of the motor power supply.

The buttons Settings X, Y, Z open the configurations of a controller, which corresponds to this axis, see [Application Settings](#).

Below the indicator blocks [Common settings](#) и [Exit](#) buttons are located.

The [Common settings](#) button opens a dialog window with general settings. Here you can choose which controller serial numbers are considered "X", "Y" and "Z" axes, also this window contains logging settings.

The [Exit](#) button performs proper shutdown, see [Correct shutdown](#).

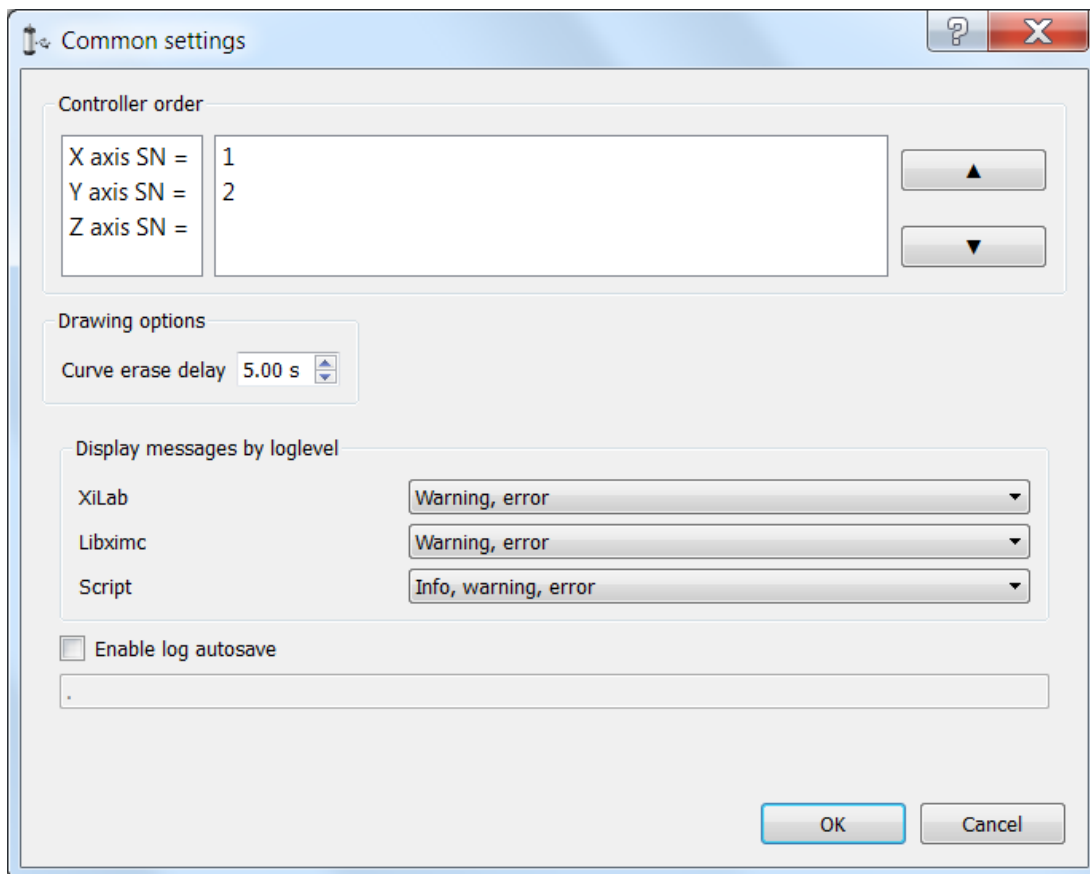

Common settings dialog window

Common settings window contains axis order settings, curve drawing options and logging settings.

You can reorder axes by choosing the axis serial, then pressing "up" or "down" buttons on the right.

First axis in the list, that is, an axis with serial number listed to the right of "X axis SN = " label will be referred to as "X axis", the second one as "Y axis", the third one, if it is available, as "Z axis".

If you enter a greater than zero value of N seconds in the "curve erase delay" control in the "Drawing options", then last N seconds of X and Y axis controller motion will be displayed as a trajectory in 2D-space overlaid on the virtual joystick window.

Common logging settings are completely identical to [single-axis version logging settings](#).

Here you can configure logging detail ("None" for no logging, "Error" to only log errors, "Error, Warning" to log errors and warnings, "Error, Warning, Info" to log errors, warnings and informational messages) for each source: XiLab itself, libximc library and Scripts module.

If the autosave option is enabled the log is saved to the file, which is flushed every 5 seconds. It has a name of type "xilab_log_YYYY.MM.DD.csv", where YYYY, MM and DD are current year, month and day respectively. The log is saved in [CSV](#) format.

5.2.4. Application settings

Settings button from the [main window](#) opens the Settings window.

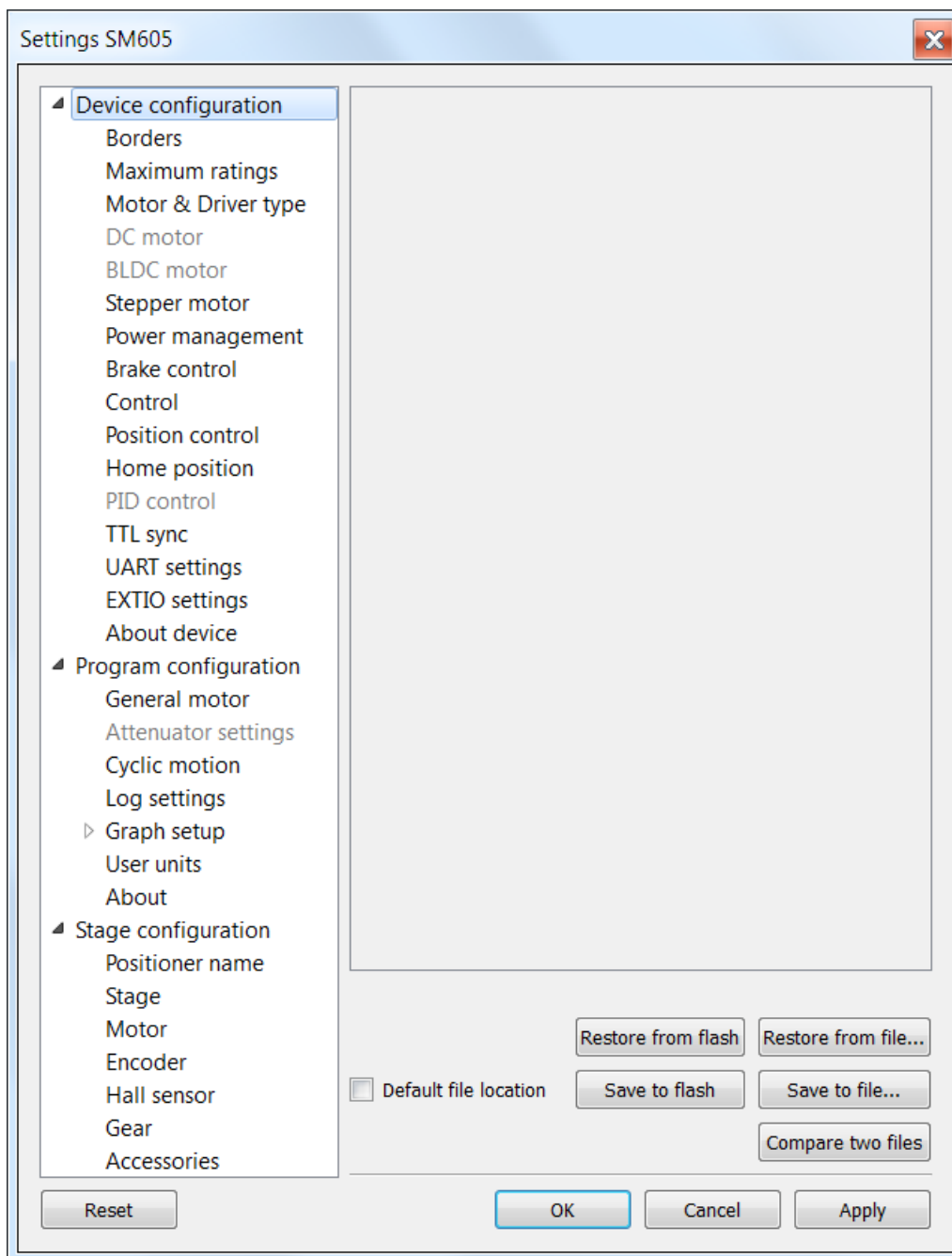

XILab Settings Main Window

Application settings are presented as a hierarchical tree and are divided into three groups: controller settings - "Device configuration", XILab application settings - "Program configuration", characteristics of a stage - "Stage configuration".

The first group **Device configuration** contains the parameters that can be stored directly in the device (in the flash memory or in the RAM of controller).

The second group **Program configuration** contains the XILab application settings, which are not written into the controller, and are used to control the XILab itself.

The third group **Stage configuration** contains information about the parameters of the stage and is read from its ROM chip.

Description of **Restore from flash** and **Save to flash** buttons is located in the [Saving the parameters in the controller flash memory](#).

All application settings from the first two groups can be saved to an external file when you click **Save to file**.

When you click the **Restore from file** button you can pick a file with application settings to be loaded into Settings window.

When you click the **Compare two files** button, a dialog window with file selection is opened. If you select two files all their settings are compared and a list of differences is displayed. Missing keys in one of the files are marked in the table as "<NO KEY>".

The **OK** Button closes the Settings window and saves all changes to the settings to the controller. The **Cancel** button closes the window without saving. The **Apply** button saves the settings without closing the window.

The **Reset** button resets all setting changes that were made since the **Apply** button was pressed, or after opening the Settings, if the **Apply** button was not pressed.

Note. Only Device configuration settings can be saved into the flash memory of the controller.

5.2.5. Charts

Button **Chart** of the [main window](#) opens a window for working with charts.

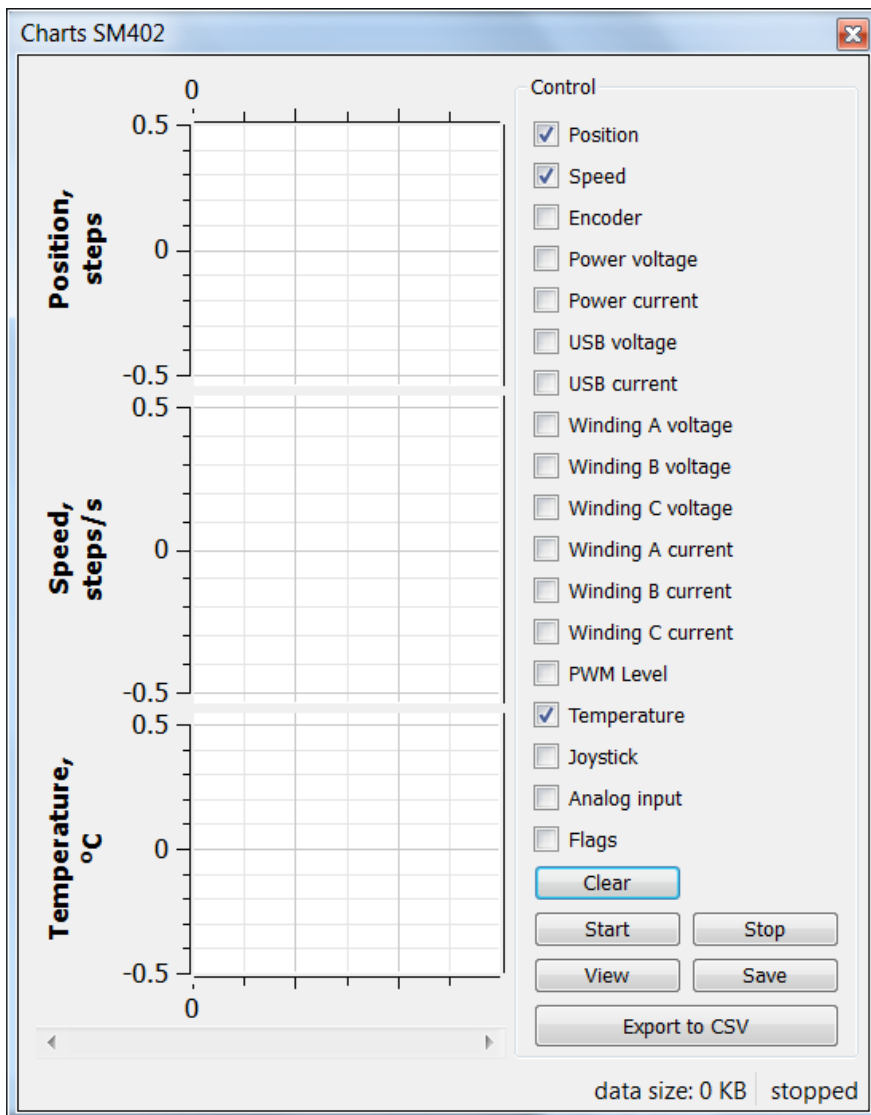

5.2.5. Charts
Values displayed on the charts
Button functions

XILab Charts window

In the left part of the window there are Charts of variables, in the right side of the window there is the **Control** block, which contains the charts control elements. Above the **Control** block there are flags which enable different charts, below the **Control** block there is a group of buttons to control the stored charts data.

Values displayed on the charts

- Position is the primary field in which the current position is stored, no matter how feedback is arranged. In the case of a DC-motor this field has the current position according to the encoder, in the case of a SM (stepping motor) this field contains the current position in steps;
- Speed is the current speed;
- Encoder is the position according to the secondary position sensor;
- Power voltage is voltage of the power section;
- Power current is current consumption of the power section;
- USB voltage is voltage on the USB;
- USB current is current consumption by USB;
- Winding A current - in the case of stepper motor, the current in winding A; in the case of a brushless motor, the current in the first winding and in the case of DC motor, the current in its only winding;
- Winding B current - in the case of stepper motor, the current in the winding B; in the case of brushless motor, the current in the second winding, unused in the case of DC motor;
- Winding C current - in the case of a brushless motor, the current in the third winding, unused in the case of DC or stepper motor;
- Winding A voltage - in the case of stepper motor, the voltage on winding A; in the case of a brushless motor, the voltage on the first winding and in the case of DC motor, the voltage on its the only winding;
- Winding B voltage - in the case of stepper motor, the voltage on the winding B; in the case of brushless motor, the voltage on the second winding, unused in the case of DC motor;
- Winding C voltage - in the case of a brushless motor, the voltage on the third winding, unused in the case of DC or stepper

motor;

- PWM level the PWM duty factor (only for DC motors);
- Temperature is temperature of controller processor;
- Joystick is value of input signal from the joystick;
- Analog input is value of analog input;
- Flags shows the state of the controller flags.

Button functions

- Clear - clears the stored data and the Charts window;
- Start - starts recording the data and displaying charts. If the option "Break data update when motor stopped" in **Program configuration** -> **Graph setup** -> **Common** is turned on, no data recording and charts auto-scrolling will occur when the motor is stopped;
- Stop - stops data reading;
- Save - stores chart data to a file;
- Load - loads chart data from a previously saved file;
- Export to CSV - exports chart data to  CSV file

5.2.6. Scripts

The "Scripts" button on the [main window](#) opens a window for working with scripts.

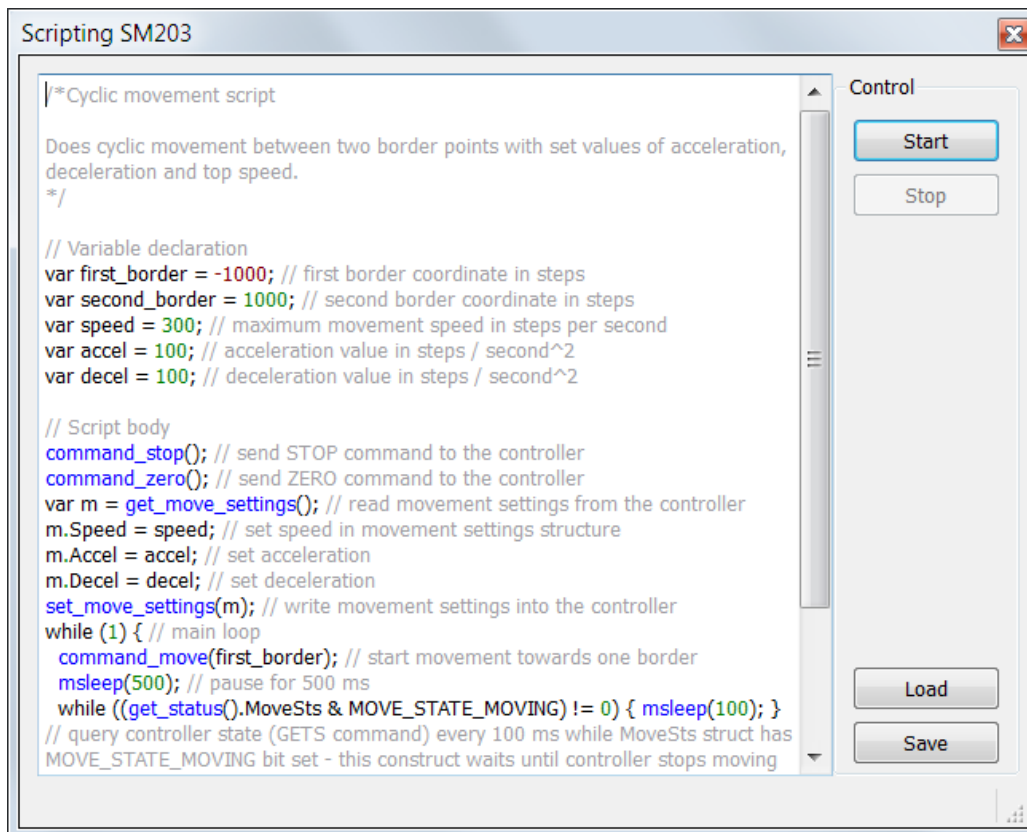

XILab scripting window

On the left side of the window a text edit field is located, on the right side of the window a Control block is located, which contains control buttons.

Button functions

- **Start** - launches the script. The button is inactive if the script is already running. Right after the button is pressed and before the script is interpreted the body of the script is autosaved to a temporary file (see below).
- **Stop** - stops the script. Inactive if the script is not running.
- **Save** - opens a file save dialog, prompting the user pick a file to save current script text to. Inactive if the script is running.
- **Load** - opens a file load dialog, prompting the user to pick a file to load into the script window. Inactive if the script is running. Warning! If you load a file all unsaved changes will be lost.

XILab loads last saved script text into the Scripting window on startup. Autosave runs on every script start and on XILab exit. Autosave file is named "scratch.txt" and is located in user settings directory.

Note.

"Stop" button in XILab main window also stops script execution, acting as an emergency stop button.

[Scripting language description](#) is located in the Programming section of the manual.

5.2.7. XILab log

Date	Time	Source	Message
2013.06.27	16:13:48.375	libximc	[1818] Cannot get friendly name for port LPT1:
2013.06.27	16:13:48.393	libximc	[1818] launch thread to probe device \\.\COM7
2013.06.27	16:13:49.293	XiLab	Device found [COM7].
2013.06.27	16:39:08.246	Script	ReferenceError: Can't find variable: i

XILab log window

XILab log at the bottom part of the main window shows libximc library messages. It also shows messages from XILab application and [Scripts](#) interpreter.

Log has 4 columns: date and time of record, the source and the message text.

Messages have a logging level indicating message importance: error, warning and informational message. Error messages are red, warnings are yellow and informational messages are green.

You can set a filter on displayed messages on the [Log settings](#) page in the Settings window.

5.3. Controller Settings

1. [Settings of kinematics \(Stepper motor\)](#)
2. [Motion range and limit switches](#)
3. [Critical board ratings](#)
4. [Power consumption settings](#)
5. [Home position settings](#)
6. [Synchronization settings](#)
7. [Brake settings](#)
8. [Position control](#)
9. [Settings of external control devices](#)
10. [UART settings](#)
11. [General purpose input-output settings](#)
12. [Motor type settings](#)
13. [Settings of kinematics \(DC motor\)](#)
14. [Settings of PID control loops](#)
15. [About controller](#)
16. [Settings of kinematics \(BLDC motor\)](#)

5.3.1. Settings of kinematics (stepper motor)

In the [Application Settings](#) **Device configuration** -> **Stepper motor**

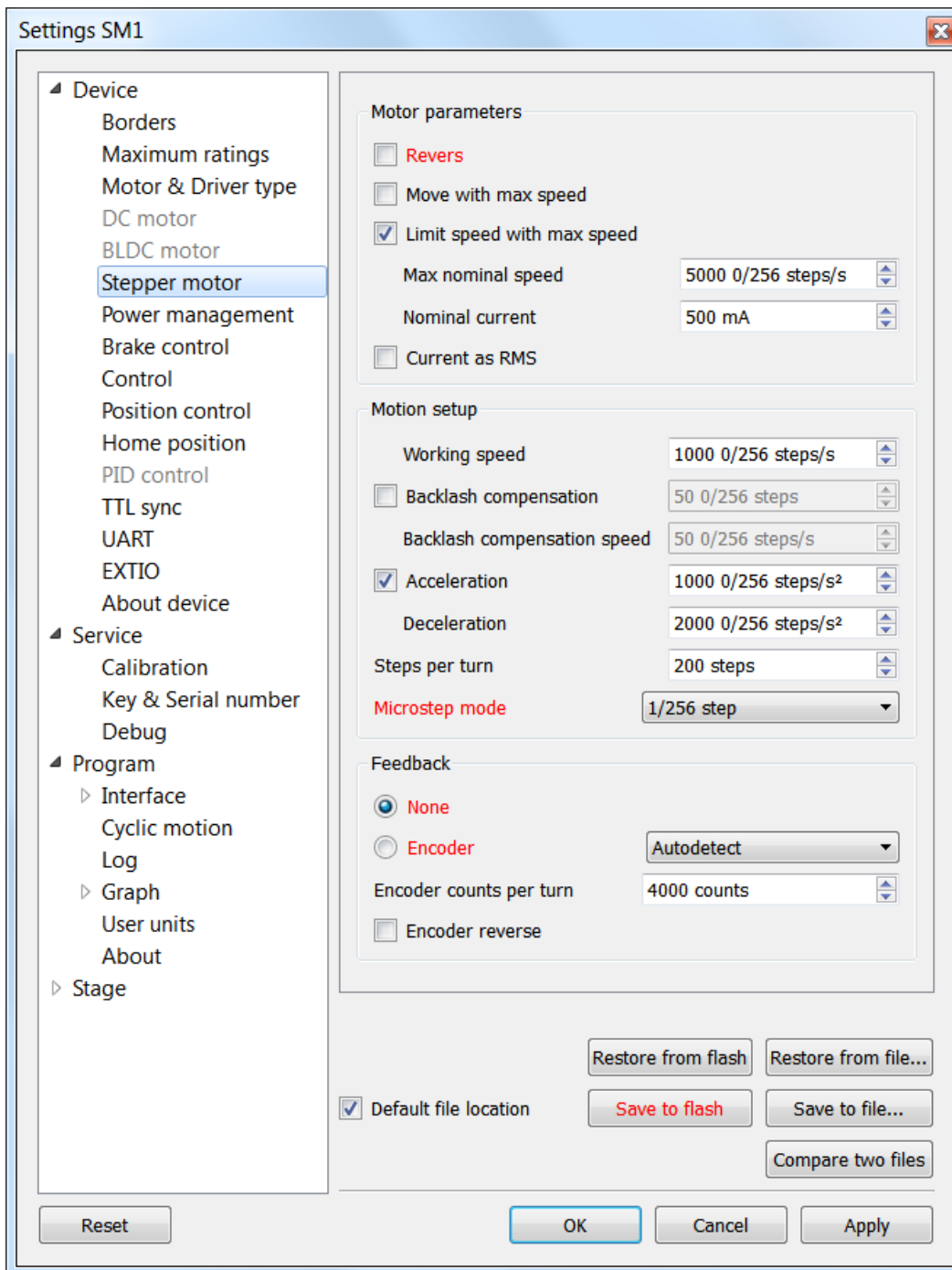

Settings of stepper motor kinematics window

Motor parameters - directly related to the electric motor settings

Revers - checking this flag associate the motor rotation direction with the position counting direction. Change the flag if positive motor rotation decreases the value on the position counter. This flag effect is similar to the motor winding reverse polarity.

Move with max speed - if this flag is checked motor ignores the preset speed and rotates at the maximum speed limit.

Limit speed with max speed - if this flag is checked the controller limits maximum speed to the value specified in the **Max nominal speed** field. For example, if the speed exceeds the rated value, controller will reduce output action, until the speed come back to the normal range. However, the controller remains operational and will continue the current task.

Max nominal speed - motor rated speed.

Nominal current - motor rated current. The controller will limit the current with this value.

Current as RMS - if this flag is checked engine current value is interpreted as root mean square current value. If the flag is unset, then engine current value is interpreted as maximum amplitude value.

Motion setup - movement kinematics settings

Working speed - movement speed.

Backlash compensation - backlash compensation. Since the stage mechanics are not ideal there is a difference between approaching a given point from the right and from the left. When the backlash compensation mode is on the stage always approaches the point from one side. The preset value determines the number of steps which the stage takes to pass a given point in order to come back to it from the same side. If the specified number is above zero the stage always approaches the point from the right. If it is below zero the stage always approaches the point from the left.

Backlash compensation speed - speed of backlash compensation. When the backlash compensation mode Backlash compensation is on the stage approaches the point from the right or from the left with a preset speed determined in the number of steps per second.

Acceleration - enables the motion in acceleration mode, the numerical value of the field is the acceleration of movement.

Deceleration - movement deceleration.

Steps per turn - determines the number of steps for one complete motor revolution. The parameter is set by user.

Microstep mode - step division mode. 9 modes are available: from a whole step to the 1/256 of a step. Description of modes is in the [Supported motor types](#).

Feedback settings

An encoder can be used as feedback sensor for stepper motors. The following encoder types are available: Single-ended, Differential or Autodetect.

Encoder counts per turn - this parameter defines the number of [encoder](#) pulses per one full motor axis revolution.

Encoder reverse - interpret encoder signal as if it were reversed.

5.3.2. Motion range and limit switches

In the [Application Settings](#) **Device configuration** -> **Borders**

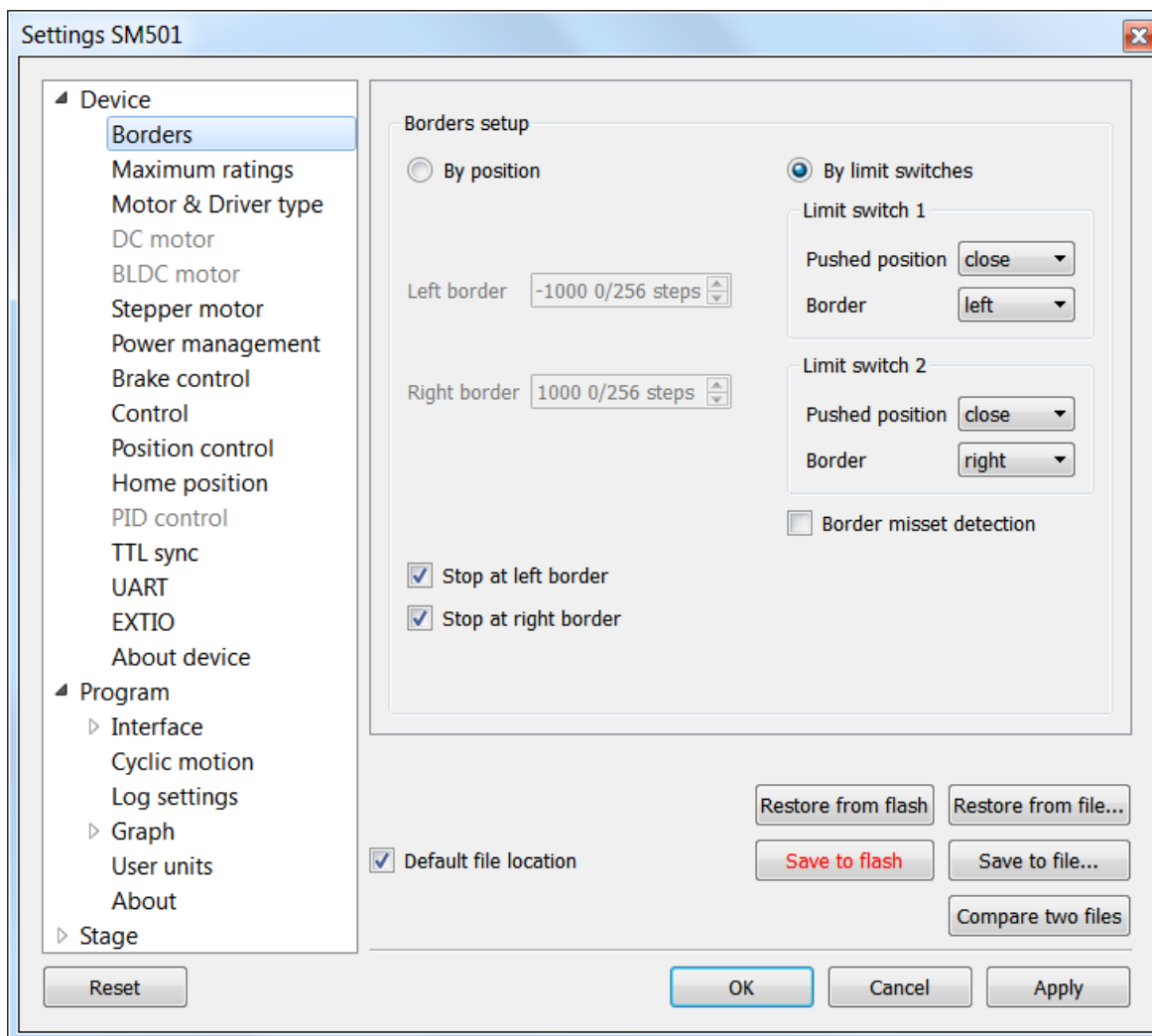

Motion range and limit switches settings window

Borders setup parameter group contains borders and limit switches parameters. These parameters are used to keep the stage in the permissible physical movement limits or motion range limit in accordance with the user requirements. Borders can be set either by position (internal controller step counter) or by [limit switches](#) located in the stage terminal points.

To set the borders by position select the [By position](#) and specify the [Left border](#) and [Right border](#) values, which correspond to the left and right edge respectively.

To set the borders by the limit switches select [By limit switches](#) and set up both [Limit switch 1](#) and [Limit switch 2](#).

[Pushed position](#) - sets the limit switch condition when it is reached: open or closed.

[Border](#) - sets the limit switch position: on the left or on the right of the stage working range.

Check the [Stop at left border](#) and / or [Stop at right border](#) for a forced stop of motor when the border is reached. In this case the controller will ignore any commands of movement towards the limit switch if the corresponding limit switch has already been reached.

When the border position is reached the corresponding indicator flashes in the main application window.

If the [Border misset detection](#) flag is checked, the engine stops upon reaching of each border. This setting is required to prevent engine damage if limit switches appear to be potentially incorrectly configured. Read more about controller operation in this mode in the [limit switches location on positioners](#).

5.3.3. Critical board ratings

In the [Application Settings](#) **Device configuration** -> **Maximum ratings**

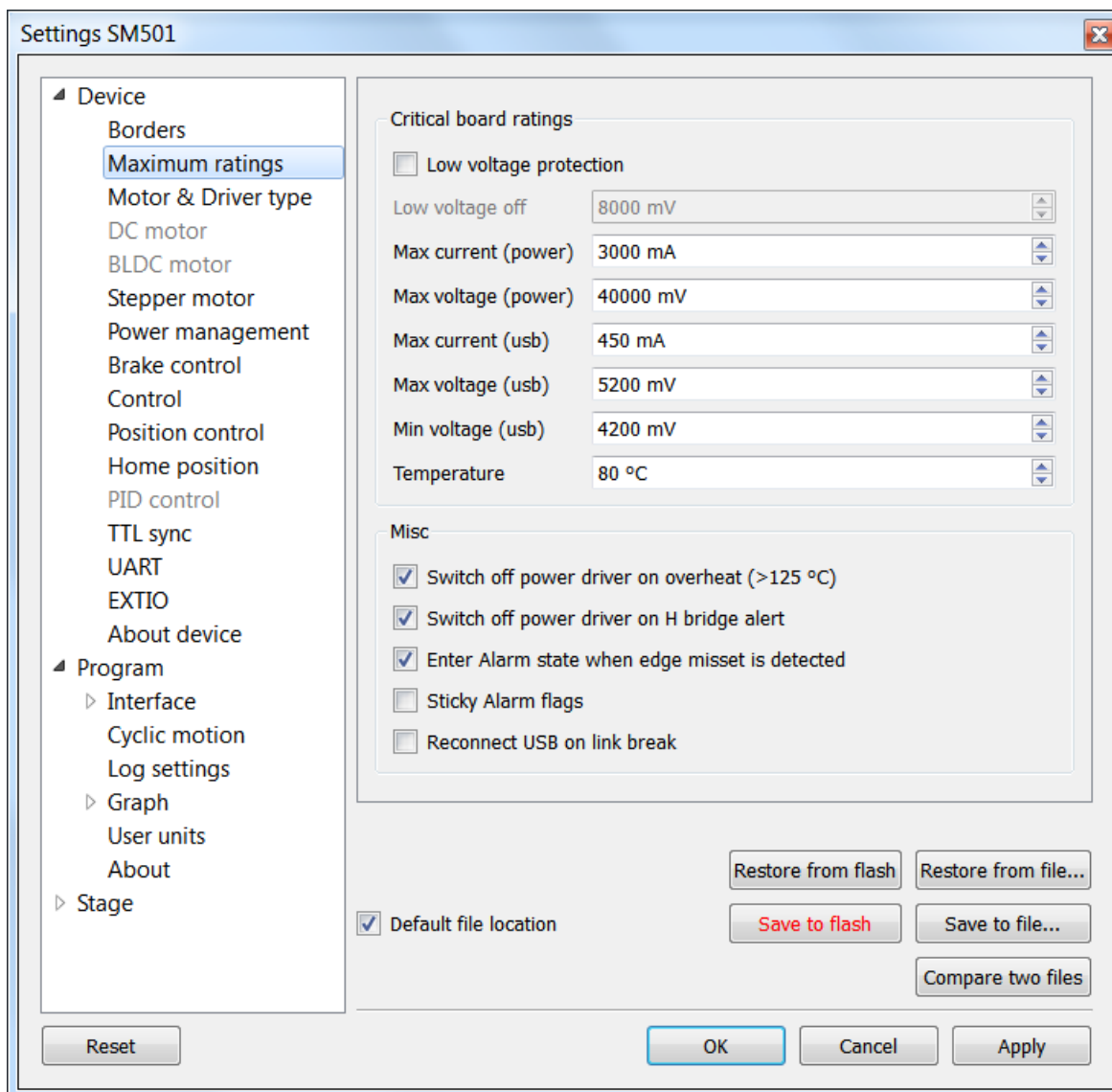

Controller critical parameters settings window

Critical board ratings - This group is responsible for the maximum values of input current Max current (power) and voltage Max voltage (power) on the controller, the maximum current Max current (usb) and voltage Max voltage (usb) for USB, the minimum voltage Min voltage (usb) for USB, and the board temperature Temperature (if the temperature is measured on the given controller version).

If the controller current consumption value, power supply voltage or the temperature goes out of the allowed range defined here then the controller turns off all power outputs and switches to [Alarm](#) state. At the same time the Alarm state information will appear in the main window (window background will change to red) and the out of range parameter value will be displayed in blue or red (below or above the limit respectively).

If the Low voltage protection flag is checked the low voltage supply protection is active. Then Low voltage off and below values of input voltage turns the controller into [Alarm](#) state.

The group **Misc** includes all other critical parameters settings.

Switch off power driver on overheat (> 125 ° C) - this parameter enables the [Alarm](#) state in case of power driver overheat.

Switch off power driver on H bridge alert - this parameter enables the [Alarm](#) state in case of the power driver malfunction signal.

Enter Alarm state when edge misset is detected - this parameter enables the [Alarm](#) state in case of incorrect boundary detection (activation of right limit switch upon moving to the left, or vice versa).

Sticky Alarm flags - locking of Alarm condition. If the Sticky Alarm flags check-box is unchecked the controller removes the Alarm flag as soon as its cause is removed (e.g. in case of over-current the windings are disconnected, which results in the decreased current). If the Sticky Alarm flags is enabled, the Alarm mode cause and the [Alarm](#) mode are canceled by the Stop command only.

Reconnect USB on link break - if this option is enabled, then the controller will reset USB link if the connection breaks.

5.3.4. Power consumption settings

In the [Application Settings](#) **Device configuration** -> **Power Management**

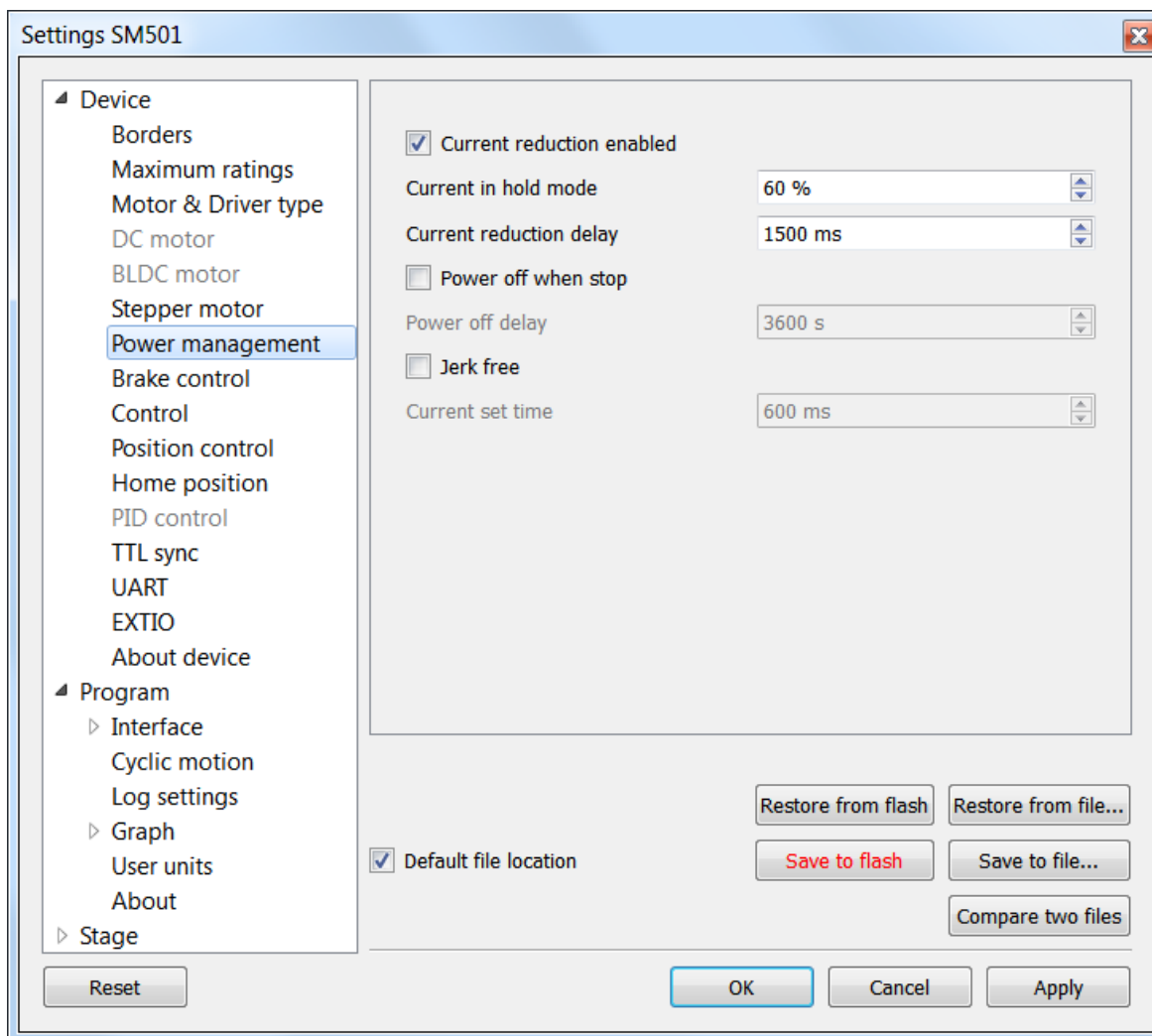

Power consumption settings window

Current reduction enabled - activates the reduced energy consumption mode.

- **Current in hold mode** - it determines the current in the hold mode in % of the nominal value. Value range: 0 .. 100%.
- **Current reduction delay** - parameter determines the delay between switching to the STOP mode and power reduction activation. It is measured in milliseconds. Value range: 0 .. 65535 ms.
- **Power off when stop** - it activates the function that deenergized the motor windings after switching to the STOP state.
- **Power off delay** - parameter determines the delay in seconds between switching to the STOP mode and motor power-off. Value range: 0 .. 65535.
- **Jerk free** - activates the current smoothing function to eliminate the motor vibration.
- **Current set time** - parameter determines the time for jerk free current setting in milliseconds. Value range: 0 .. 65535 ms.

Detailed description of these parameters see in the [Power control](#) section.

5.3.5. Home position settings

In the [Application Settings](#) **Device configuration** -> **Home position**

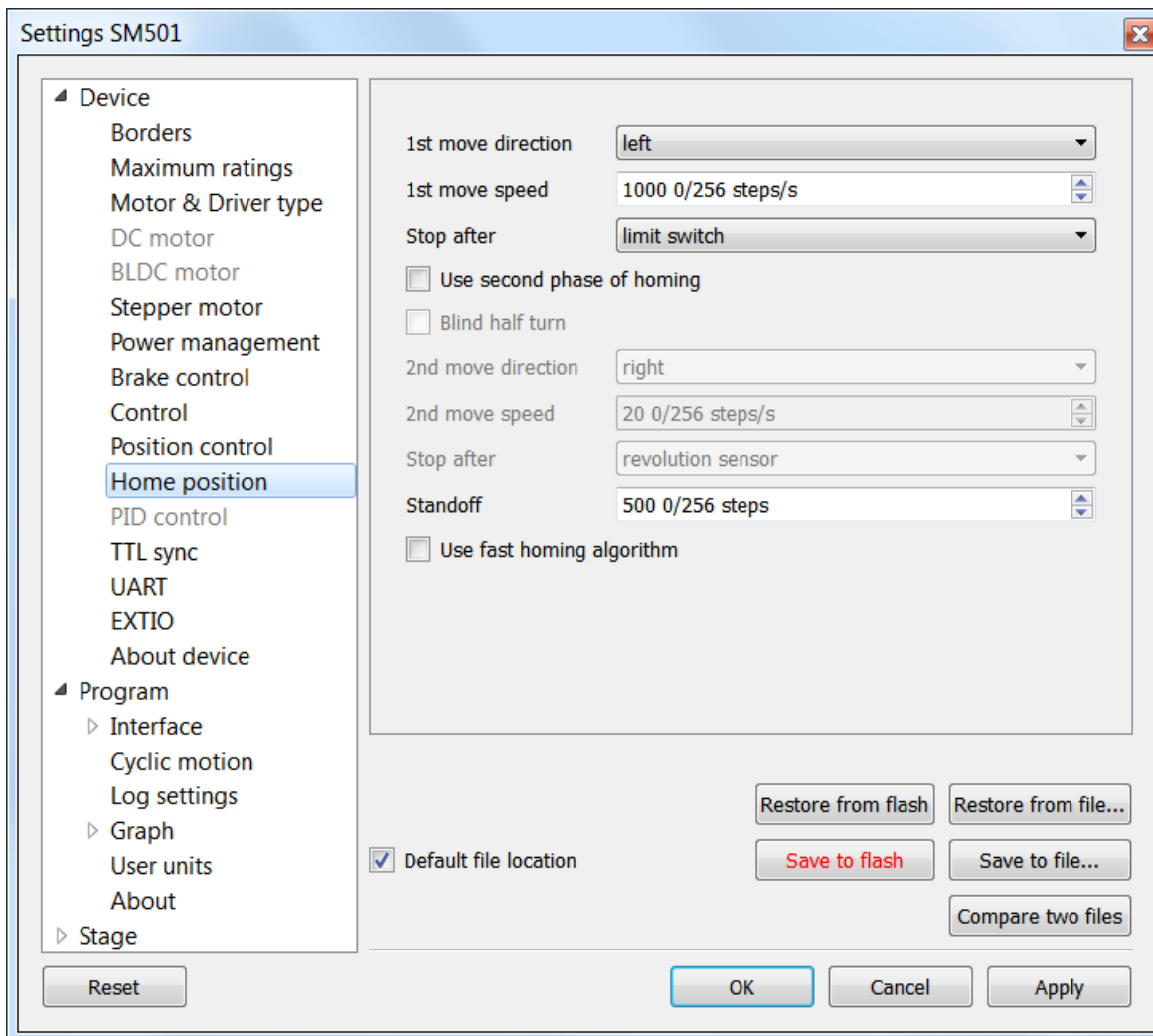

Home position settings window

Tab **Home position** sets the home position calibration parameters. Calibration comes to automatic accurate detection of the [limit switch](#), the [revolution sensor](#) signal or moment of getting the external signal, which determines the zero position, and grading from it by a specified offset. It is helpful when the current location of the stage is unknown but we know the base point position relative to limit switch or some other signal, which is called home position.

Homing comes to the motor movement towards the predetermined [1st move direction](#) (left or right) at [Working speed](#) until the signal from the source [stop after](#) don't happen. Then the motor movement towards the opposite direction with the same speed until the signal from the source [stop after](#) in the active state and continue half turn in the same direction. Then begins the precise movement in a given direction [1st move direction](#) at [1st move speed](#). The speed is usually set low enough to keep the next signal. Motor stops, depending on the [stop after](#) value, upon getting a sync input signal, signal from RPM sensor or reaching of the limit switch.

If the flag [Use second phase of homing](#) is checked the homing algorithm rotates the motor in a predetermined [2nd move direction](#) (left or right) with the [2nd move speed](#).

If the flag [Blind half turn](#) is checked the motor ignores the end of the second phase signal during half a turn. It helps to set an unambiguous detection order for the sensors that have the first and the second movement phases signals close each other.

The third phase of homing is the absolute offset to the distance [standoff](#).

The resulting point is called a home position. It is important that its location on the stage does not depend on the calibration starting point.

[Use fast homing algorithm](#) option uses [Working speed](#) (see [Settings of kinematics \(stepper motor\)](#) page) for the first phase of homing to speed up the process.

Configuration commands are described in the [Communication protocol specification](#) section.

5.3.6. Synchronization settings

In the [Application Settings](#) **Device configuration** -> **TTL sync**

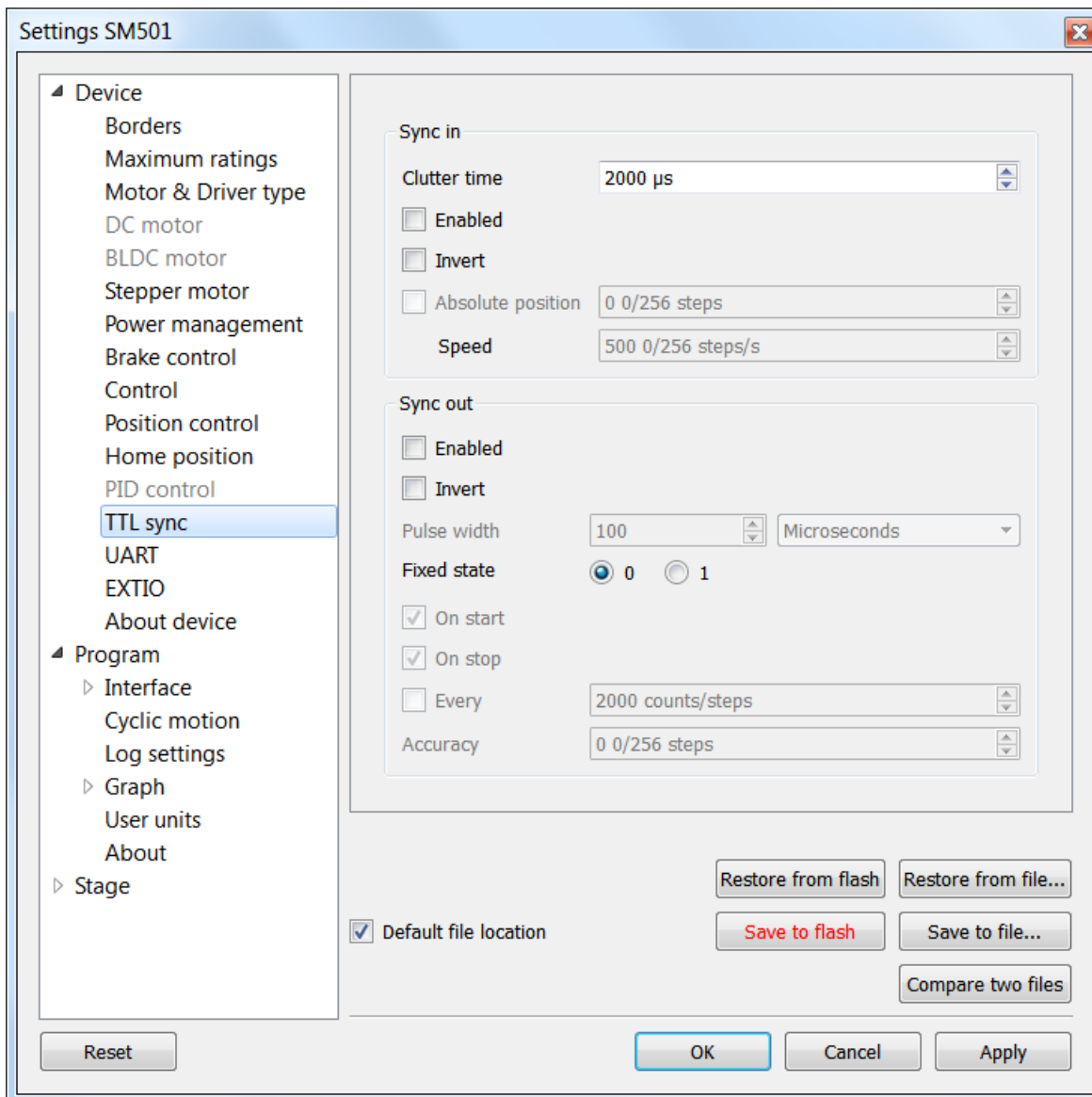

Synchronization settings window

Synchronization is described in details in [TTL synchronization](#) section.

Sync in

Clutter time - setting minimum synchronization pulse duration (in microseconds). Defines the minimum duration, which can be detected (anti-chatter).

Enabled - check this box for the sync in mode enable.

Invert - checked flag shows that the operation is triggered by the falling sync pulse edge.

Absolute position - if the flag is checked, upon sync pulse the stage moves into the absolute position specified in the field Step/Micro step. If the flag is unchecked, the shift is relative to the defined destination position.

Speed - the speed to use when moving.

Sync out

The Synchronization Output can be used as a "General purpose Output signal".

Enabled - if the flag is checked, the sync output functions according to the next settings. If the flag is unchecked, the output value is fixed and equal to the **Fixed state**.

Invert - if the flag is checked the zero logic level is set to active.

Pulse width - specifies the duration of the output signal in milliseconds or steps/encoder pulses.

Fixed state - sets the logic level of output to 0 or 1, respectively.

On start - synchronizing pulse is generated at the beginning of movement.

On stop - synchronizing pulse is generated at the end of movement.

Every - synchronizing pulse is generated every n encoder pulses.

Accuracy - distance to the target position. As soon as the distance to target on approach is less than or equal to this distance a synchronizing pulse will be generated if "on stop" option is used.

5.3.7. Brake settings

In the [Application Settings](#) **Device configuration** -> **Brake control**

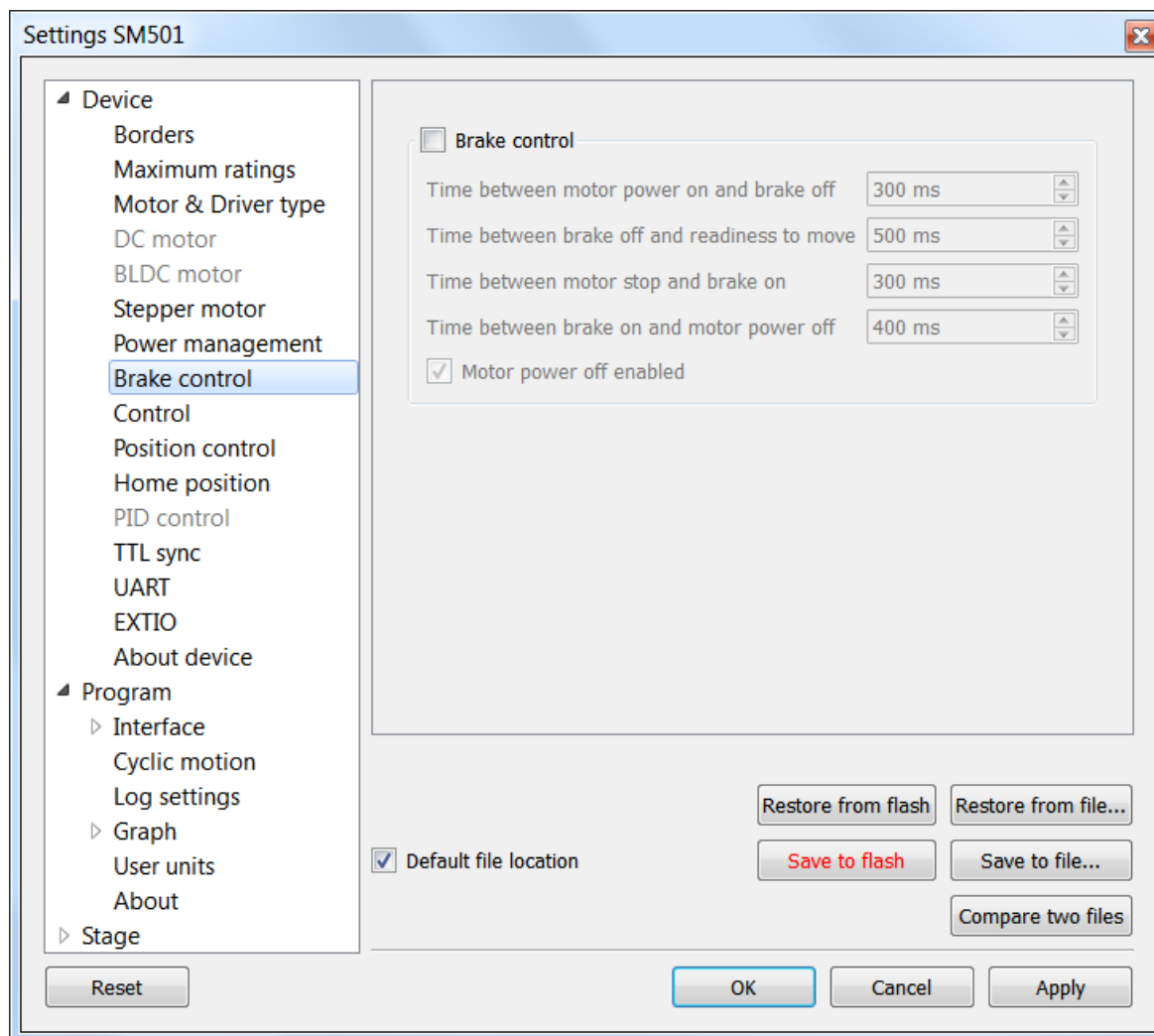

Magnetic brake settings window

Check the [Brake control](#) flag to enable magnetic brake.

Parameters:

[Time between motor power on and brake off](#) - time between switching the motor on and switching off the brake (ms).

[Time between brake off and readiness to move](#) - time between switching off the brake and motion readiness (ms). All motion commands will be executed only after this time.

[Time between motor stop and brake on](#) - time between stopping the motor and turning on the brake(ms).

[Time between brake on and motor power off](#) - time between turning on the brake and motor power-off (ms).

Value range is from 0 to 65535 ms.

[Motor power off enabled](#) flag means that when magnetic brake is powered off, the brake turns off motor power supply.

Configuration commands are described in [Communication protocol specification](#).

5.3.8. Position control

In the [Application Settings](#) **Device configuration** -> **Position control**

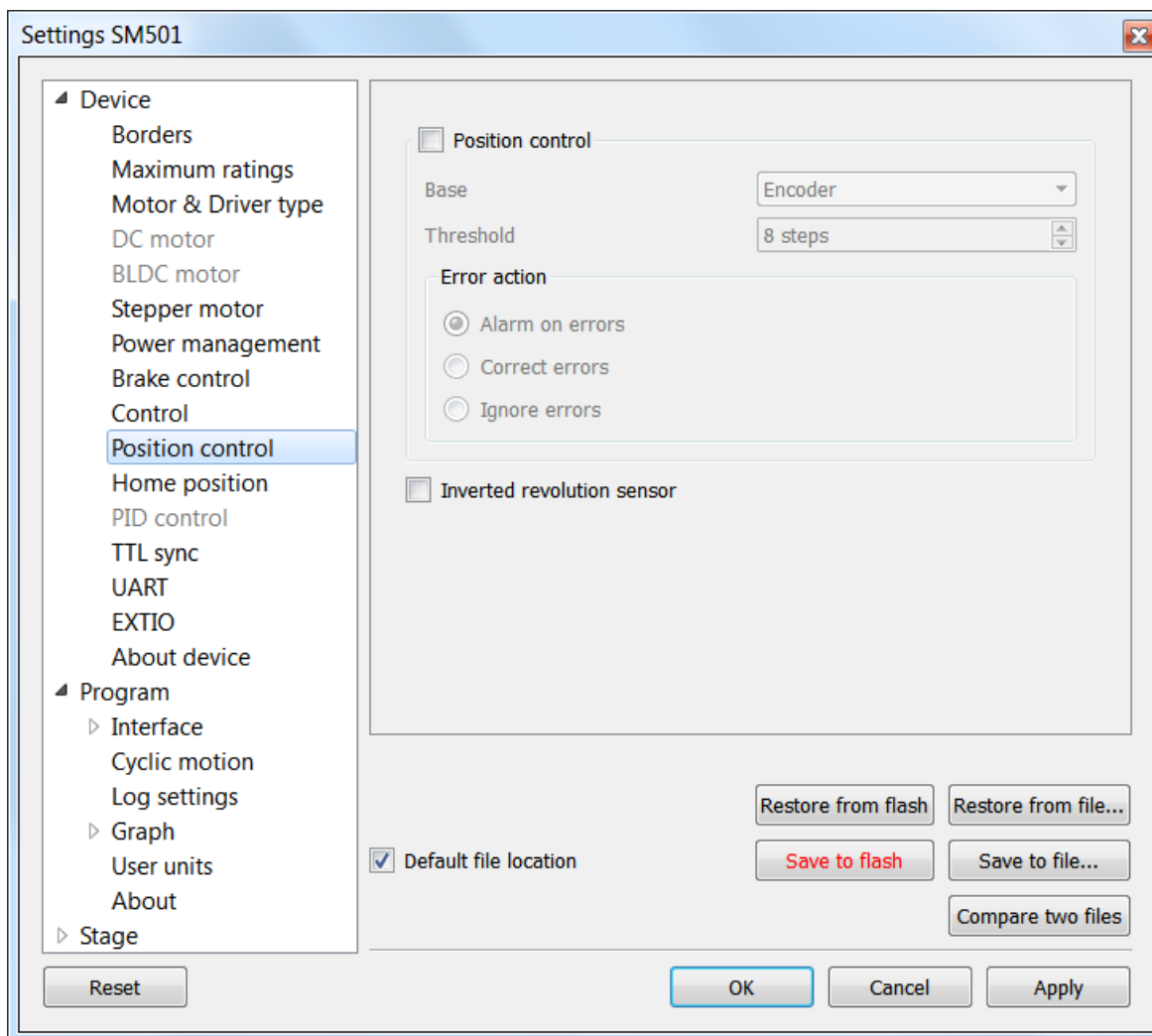

Window of Position control

Check the [Position control](#) checkbox to activate the position control.

Base - selection of the position control device. You can select an encoder (see [Operation with encoders](#)) or revolution sensor in the drop-down list.

Minimal error - determines the number of missed steps (0 .. 255), which is considered to be an error. If the amount of missed steps exceeds the specified number of steps the SLIP error flag is set. Further actions depend on the [Error action](#) setting:

If [Alarm on errors](#) is active then the controller will enter [Alarm state](#).

If [Correct errors](#) is active then the controller will try to correct slip error (see [Steps loss detection](#)).

If [Ignore errors](#) is active then the controller will do nothing.

Inverted revolution sensor - if the flag is checked the revolution sensor is triggered by the level 1. Unchecked flag means usual logic is valid - 0 is the trigger/activation/active state.

Configuration commands are described in the [Communication protocol specification](#).

5.3.9. Settings of external control devices

In the [Application Settings](#) **Device configuration** -> **Control**

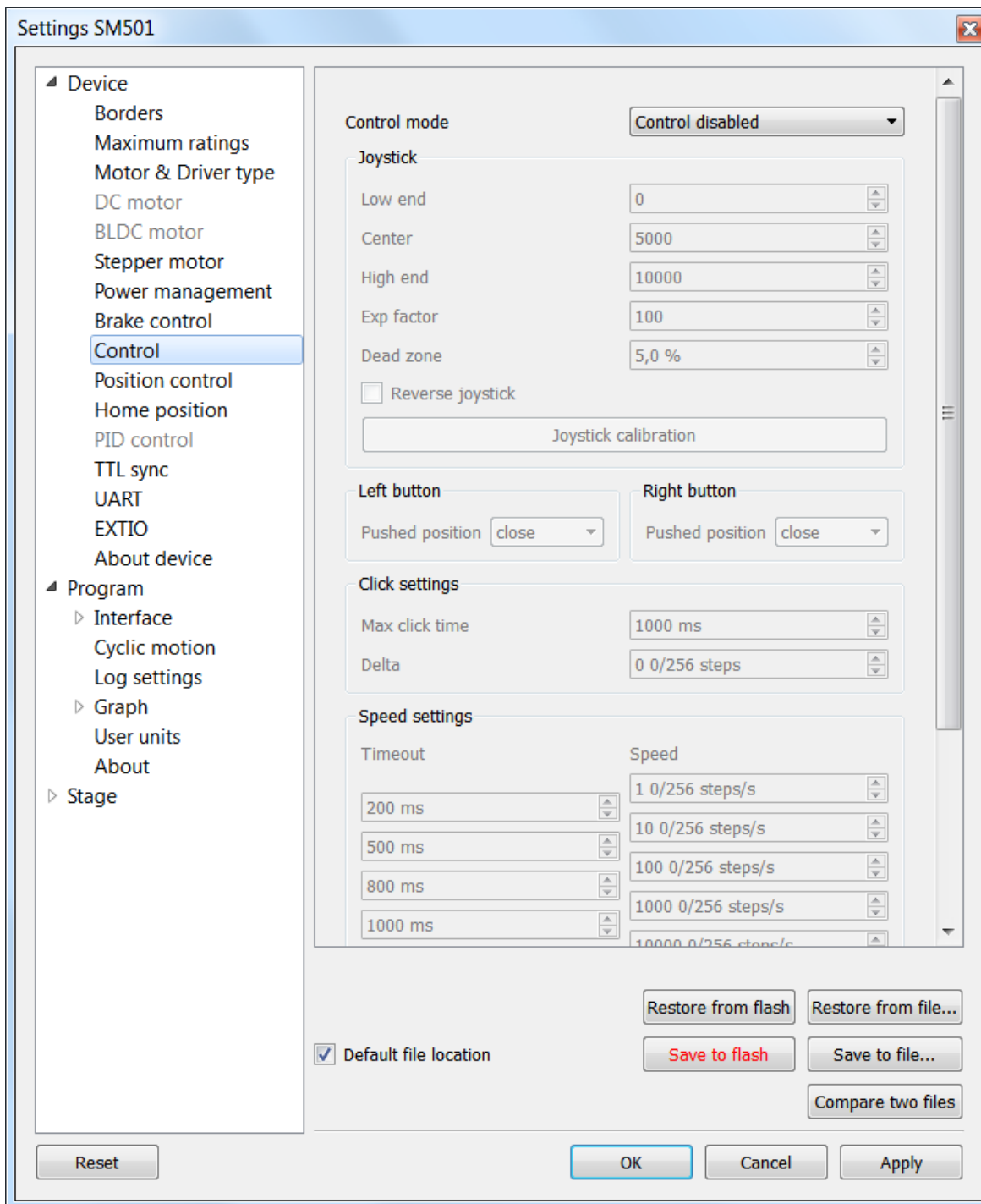

Settings of external control devices window

Control mode - range of external motor control devices.

- **Control disabled** - external devices are not used
- **Joystick** - joystick is used
- **Buttons** - buttons are used

Joystick block contains joystick settings.

Low end, **Center** and **High end** determine the lower border, the middle and the upper border of joystick range respectively. Hence the joystick ADC normalized value equal to or less than **Low end** corresponds to the maximum joystick deflection towards lower values.

Exp factor - exponential nonlinearity parameter. See [Joystick control](#).

Dead zone - dead zone of joystick deviation from the center position. Minimum step of variation: 0.1%, the maximum value is 25.5%. The joystick deviation from **Center** position by less than **Dead zone** value corresponds to zero speed.

Reverse joystick - Reverse the joystick effects. Joystick deviation to large values results in negative speed and vice versa.

Button **Joystick calibration** opens calibration dialog box.

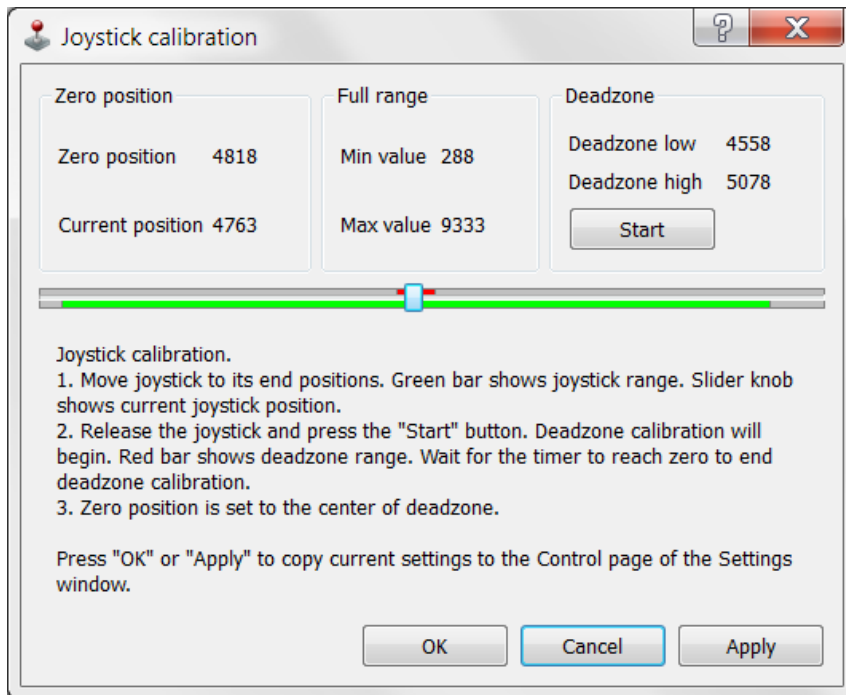

Dialog box of Joystick Calibration

Calibration is automatic border and the dead zone detection. Below is the process description:

Move the joystick to extremes to determine the borders. The range of all measured values is represented in a green line.

Release the joystick and press the Start to initiate detection of the dead zone. Within 5 seconds imitate accidental influences on the joystick, which should not be recognized as deviation from the joystick zero position. The dead zone range is represented in red.

Pressing the Apply button will send the computed values into the Settings window. Pressing OK button will send the values and close the calibration dialog box.

Left button and **Right button** blocks contain button settings.

Pushed Position - determines the state (pressed or released button) which is considered the motion signal by the controller.

- **Open** - released button is considered to be a motion command.
- **Close** - depressed button is considered to be a motion command.

Click settings block lets one to set up button "click" behaviour. A rapid press of a button is interpreted as a "click".

Max click time - Maximum click time. Until this amount of time is elapsed controller will not start moving with first speed (see below).

Delta - Relative position offset. Controller will do a shift on offset with each click.

Speed settings block contains timeout and speed settings.

Timeout [i] - the time after which the speed switches from Speed[i] to Speed[i+1]. If any of the Timeout[i] is equal to zero, no switching to the next speeds will occur.

Speed[i] - speed of the motor after time equal to Timeout[i-1]. If any of the speeds is equal to zero, no switching to this and subsequent speeds will occur.

Configuration commands are described in [Communication protocol specification](#).

5.3.10. UART Settings

In the [Application Settings](#) **Device configuration** -> **UART**

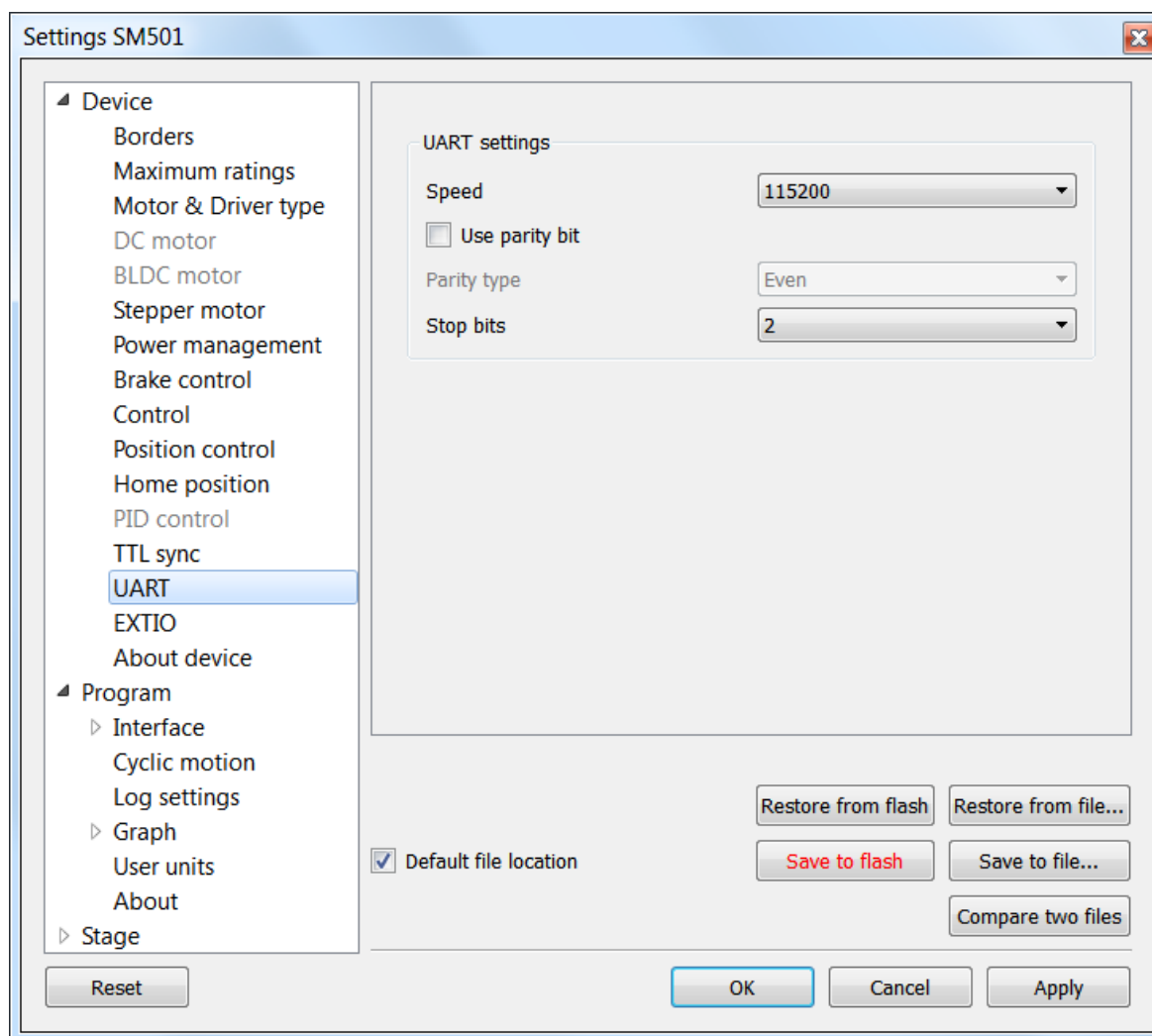

UART settings tab

Speed - Select the UART speed from the preset values in the range from 9600 bit/s to 921600 bit/s.

Use parity bit - use of parity bit.

Parity type - Types of parity:

- **Even** - this bit type is set when total number of bits is odd
- **Odd** - this bit type is set when total number of bits is even
- **Space** - parity bit is always 0
- **Mark** - parity bit is always 1

Stop bits - number of stop bits (1 or 2).

5.3.11. General purpose input-output settings

In the [Application Settings](#) **Device configuration** -> **EXTIO settings**

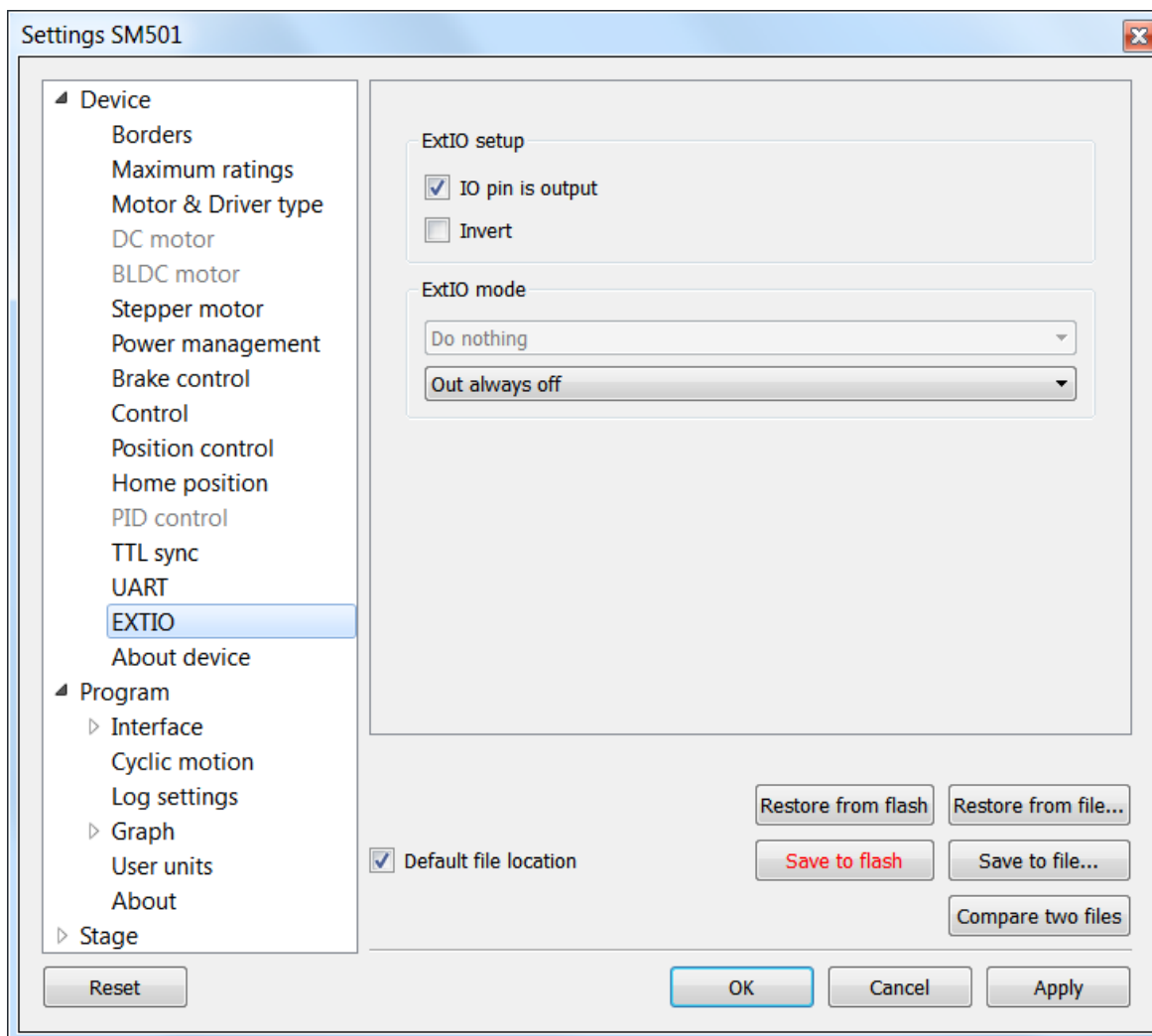

General purpose input-output settings tab

For detailed information, please see [General purpose digital input-output](#).

ExtIO setup

IO pin is output - if the flag is checked the needle of ExtIO works in output mode, otherwise - in the input mode.

Invert - if the flag is checked the rising edge is ignored and the falling edge is active.

ExtIO mode - mode selection

If ExtIO configured for input mode the choice of controller action settings by the input pulse is active:

- Do nothing - do nothing.
- Stop on input - run STOP command.
- Power off on input - run PWOFF.
- Movr on input - run MOVR.
- Home on input - run HOME.
- Alarm on input - enter ALARM state.

If ExtIO configured for output mode the choice of the output state depending on the controller status is active:

- Out always off - always in inactive state.
- Out always on - always in active state.
- Out active when moving - in active state during motion.
- Out active in Alarm - in active state if the controller is in the Alarm state.
- Out active when motor is on - in active state if the motor windings are powered.
- Out active when motor is found - in active state if the motor is connected.

5.3.12. Motor type settings

In the [Application Settings](#) **Device configuration** -> **Motor type**

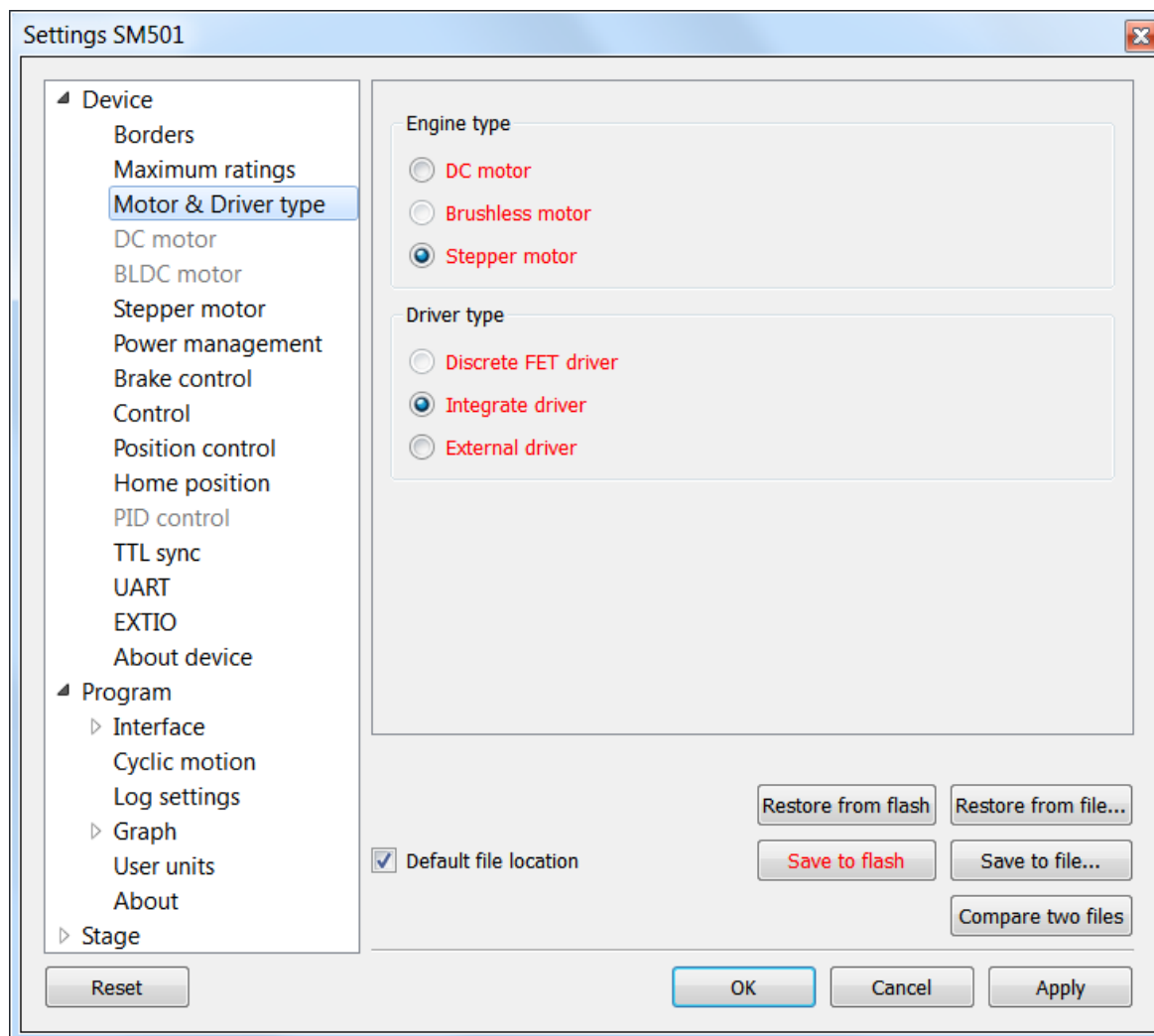

Motor type settings window

Stepper motor or DC-motor - motor type indication. Control power driver should be selected as well:

- Integrated. This type is used for this controller modification.
- On discrete keys. Will be used in future versions.
- [External driver](#). Designed to control stepper motors using three standard signals (see [External driver control interface](#))

Warning. Driver type or motor type change is a critical operation that should not be performed while motor rotates. To implement the change correctly the motor winding should be de-energized and turned off, after that motor type can be changed and motor of another type can be connected. The same applies to changing of integrated driver to external one and vice versa.

Note. Available motor types are determined by your firmware upgrade. Available control drivers depend on the controller board type, except for the external driver.

5.3.13. Settings of kinematics (DC motor)

In the [Application Settings](#) **Device configuration** -> **DC Motor**

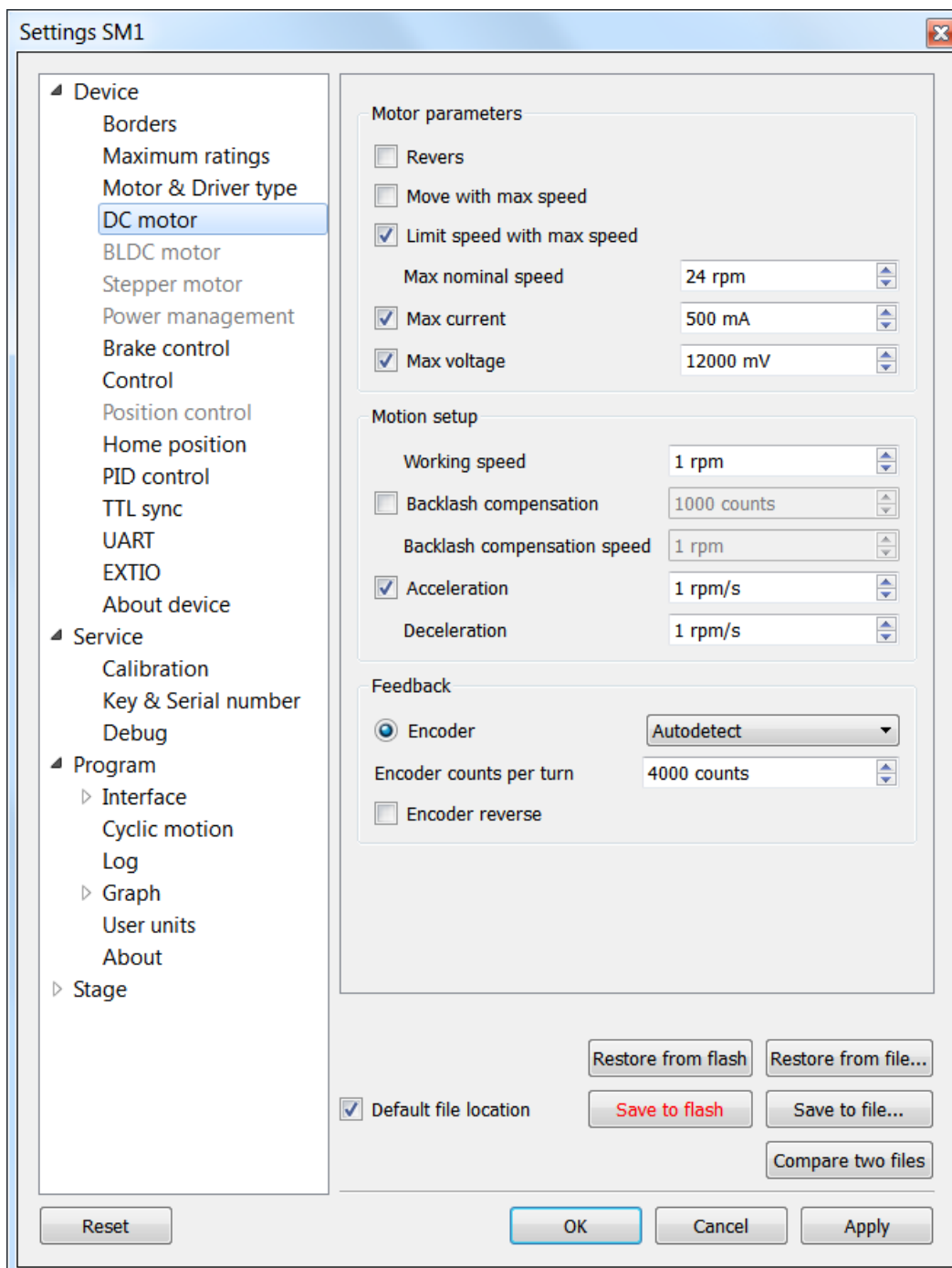

Settings of kinematics (DC motor) window

Motor parameters - electric motor settings

Revers - checking this flag associate the motor rotation direction with the current position counting direction. Change the status of the flag if positive motor rotation decreases the value on the position counter register. This flag effect is similar to connecting the motor winding to reverse polarity.

Move with max speed - if this flag is checked motor ignores the preset speed and rotates at the maximum speed limit.

Limit speed with max speed - if this flag is checked the controller limits the maximum speed to the number of steps per second, specified in the **Max nominal speed** field.

Max nominal speed, Max voltage, Max current - are motor nominal parameters. If they are active and applicable for given type of motor, the controller limits these parameters within the specified values. For example, if the motor speed and voltage exceeds the nominal values, the controller will reduce output action until both values are within the normal range. However, the controller remains in operational condition, and will execute the current task.

Motion setup - settings related to the movement kinematics

Working speed - movement speed.

Backlash compensation - backlash compensation. Since the stage mechanics are not ideal there is a difference between approaching a given point from the right and from the left. When the backlash compensation mode is on the stage always approaches the point from one side. The preset value determines the number of steps which the stage takes to pass a given point in order to come back to it from the same side. If the specified number is above zero the stage always approaches the point from the right. If it is below zero the stage always approaches the point from the left.

Backlash compensation speed - speed of backlash compensation. When the backlash compensation mode Backlash compensation is on the stage approaches the point from the right or from the left with a preset speed determined in the number of steps per second.

Acceleration - enables the motion in acceleration mode, the numerical value of the field is the acceleration of movement.

Deceleration - movement deceleration.

Feedback settings

Encoder - use of [encoder](#) as a feedback sensor. The following encoder types are available: Single-ended, Differential or Autodetect.

Encoder counts per turn - this parameter defines the number of encoder pulses per one motor axis full rotation.

5.3.14. Settings of PID control loops

In the [Application settings](#) **Device configuration** -> **PID control**

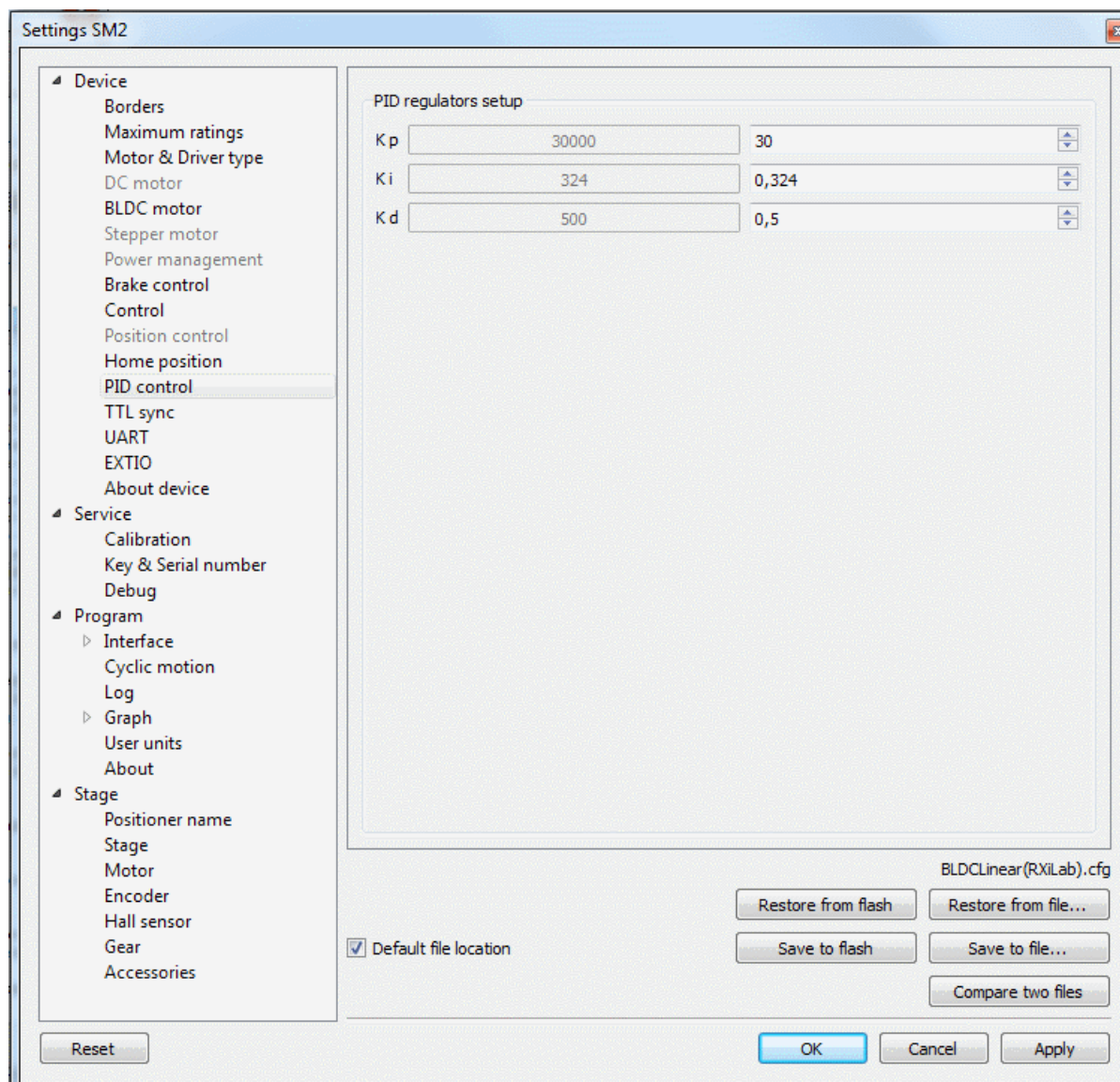

Settings of PID control loops window

In this section, you can change the PID coefficients.

A voltage PID is used, K_p , K_i and K_d coefficients can vary in 0..65535 range for DC motors.

Fractional PID coefficients (on right) are only for BLDC motor (supported in firmware 4.1.x and older).



Warning. Do not change the settings of PID controllers, if you are not sure you know what you are doing!

Configuration commands are described in the [Communication protocol specification](#). PID tuning is described in detail in the [PID-algorithm for DC engine control](#) section.

5.3.15. About controller

In the [Application Settings](#) **Device configuration** -> **About device**

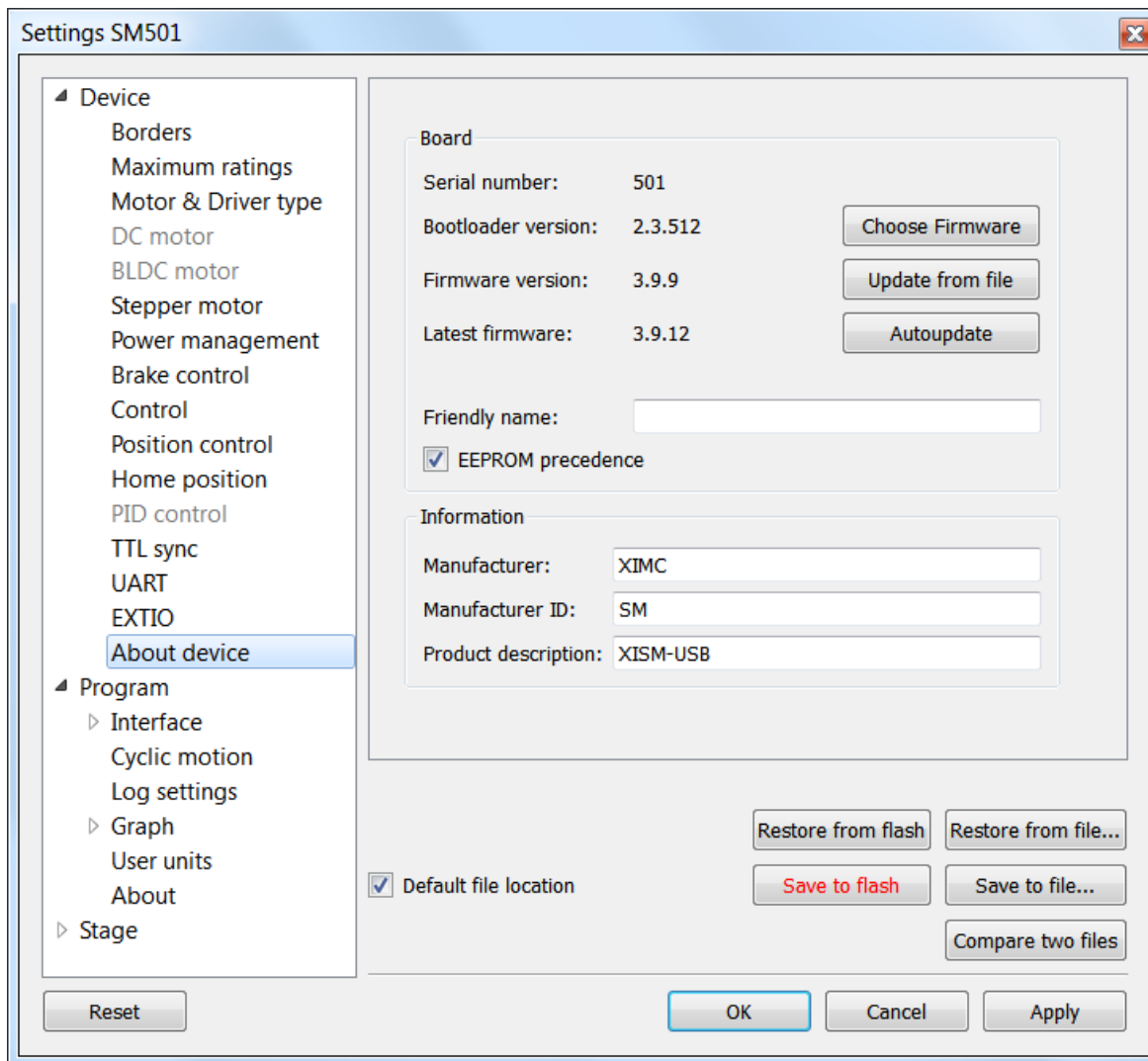

About device tab

The **Board** section displays information about the controller:

Serial number - device serial number.

Bootloader version - bootloader version.

Firmware version - firmware version.

Latest firmware - latest available firmware version for this device (downloaded from the internet if internet connection is available).

The Update button opens firmware update dialog box.

Select the firmware file with the .cod extension and click Open. XILab will start the firmware update and will display "Please wait while firmware is updating". Do not power off the controller during the upgrade. Upon completion of the update the "Firmware updated successfully" dialog will be displayed.

The Choose Firmware button opens a dialog with firmware version numbers. Pick a number and press "Update firmware" to update to selected version. An appropriate firmware file will be downloaded from the internet and loaded into the controller. This feature requires an active internet connection.

The Autoupdate button automatically updates firmware from the internet to the latest available version.

Friendly name - an arbitrary user-defined name for the controller. If this string is not empty, then it will replace device id and serial number in window titles. This is a convenience feature for situations with multiple controllers connected to the same PC.

EEPROM precedence - this flag works only for stages with [autodetection feature](#). If this flag is set, then settings from external EEPROM memory take precedence and are applied every controller start up or positioner connection. Otherwise settings from FRAM are used. If this option is turned on then "Save to flash" button is displayed in red. This serves as a warning to the user that settings in flash memory will be overwritten when a device with external memory is plugged into the controller.

Information block contains information about the device: the manufacturer, device ID, device type. The data are read from the internal memory of the controller.

All of this data is reported to the XILab application when the device is connected.

5.4. XILab application settings

1. [XILab general settings](#)
2. [General motor settings](#)
3. [Attenuator settings](#)
4. [Cyclical motion settings](#)
5. [Log settings](#)
6. [Charts general settings](#)
7. [Charts customization](#)
8. [User units settings](#)
9. [About the application](#)

5.4.1. XILab general settings

Program configuration in the [Application Settings](#)

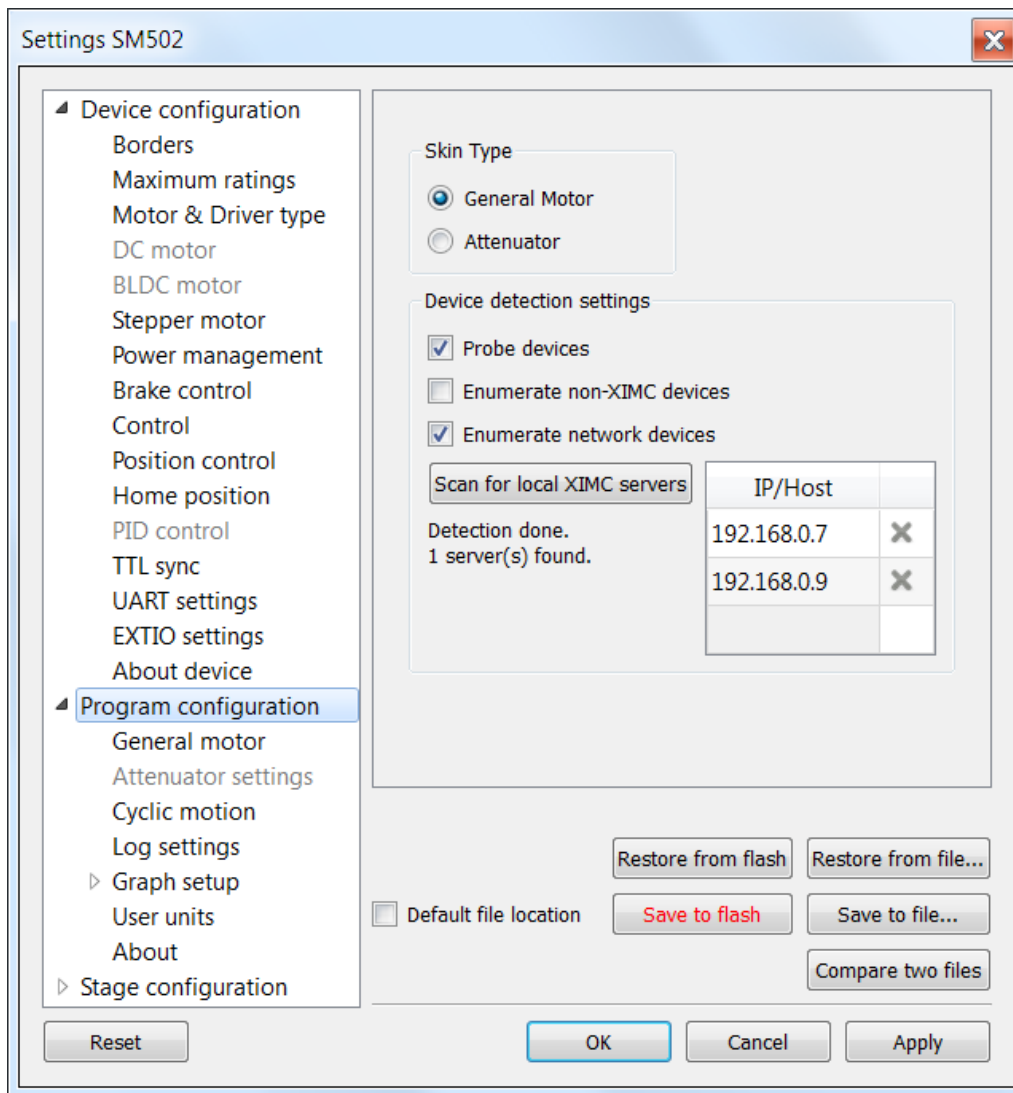

XILab general settings tab

This tab configures the Xilab interface type and XIMC devices detection options.

Skin Type group includes Xilab interface type settings. There are two interface types available: "General Motor" and "Attenuator".

General Motor option enables general motor interface. In this mode current motor position is displayed in main window numerically and graphically as a slider. Controls to move the motor to specified coordinate (in steps) and to shift on specified offset (in steps) are also available. General motor interface settings are located on the [General motor settings](#) page.

Attenuator option enables Attenuator interface. In this mode current motor position is displayed in main window graphically as a series of circles representing attenuator filters. Controls to find the combination of filters which is the best approximation to the specified transparency are also available. Attenuator interface settings are located on the [Attenuator settings](#) page.

Device detection settings group includes XIMC device detection settings.

If **Probe devices** option is checked, at the start application tries to identify controllers by sending them commands GETI and GSER.

If **Enumerate non-XIMC devices** option is checked the application queries all COM-port type devices in the system. If the option is disabled, only devices with names matching the XIMC mask ("XIMC Motor Controller" in Windows; /dev/ximc/* and /dev/ttyACM* in Linux/Mac) are queried.

If **Enumerate network devices** option is checked the application queries network-attached devices. A list of domain names and/or IP addresses with XIMC server software is located below. One can add entries to the list manually or use automatic detection by pressing **Scan for local XIMC servers**. Please note that in case of more than one local server automatic scan will pick a random one and it will require several attempts to find them all.



Warning. If both Probe devices and Enumerate non-XIMC devices options are enabled, on startup XILab will send data to all COM-ports.

If the PC has multiple Bluetooth COM-ports, due to the nature of Bluetooth operation, the queries will be conducted sequentially, and connection attempts may take from a few to tens of seconds each.

5.4.2. General motor settings

General motor in the [Application Settings](#)

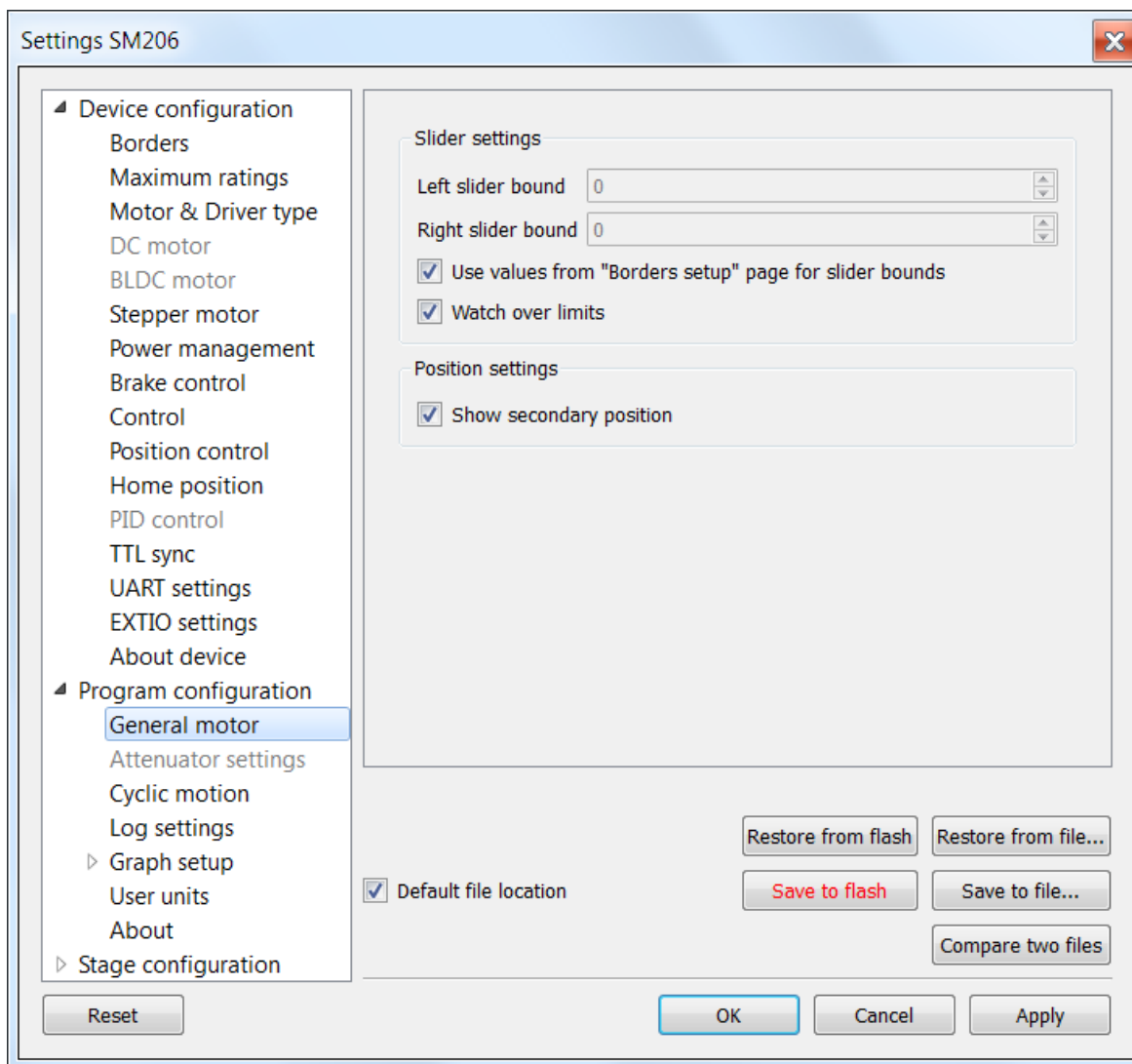

General motor settings tab

This tab configures the slider display settings and secondary position display settings for a general motor device. The position slider is located in the [main window](#) and visually represents the stage current position relative to the borders.

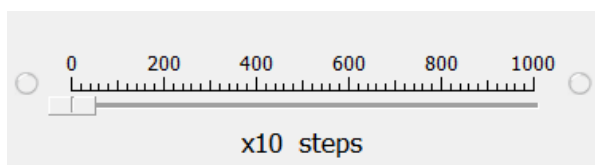

Fragment of Main application window containing slider

Slider settings group contains the following slider settings:

[Left slider bound](#) and [Right slider bound](#) contain the coordinates of the left and right bounds of the slider respectively.

If [Watch over limits](#) is checked then upon moving out of the slider range, the scale shifts to display the current position. However, the total distance displayed on the slider remains unchanged. This option is not used by default. It is useful when you know the stage motion range, but do not know the relation of that position to the values displayed in XILab, e.g. for the calibration purposes. The option is often used together with the settings of the tab [Home position settings](#).

Position settings group contains the position display settings.

If [Show secondary position](#) is checked then a secondary position is shown in the main application window.

5.4.3. Attenuator settings

In the [Application Settings](#) **Program configuration** -> **Attenuator settings**

Settings SM210

Device configuration

- Borders
- Maximum ratings
- Motor & Driver type
 - DC motor
 - BLDC motor
 - Stepper motor
- Power management
- Brake control
- Control
- Position control
- Home position
- PID control
- TTL sync
- UART settings
- EXTIO settings
- About device

Service

- Calibration
- Key & Serial number
- Debug

Program configuration

- General motor
- Attenuator settings**
- Cyclic motion
- Log settings
- Graph setup
- User units
- About
- Stage configuration

Attenuator Settings

Attenuator type

One Wheel

Two Wheels

Wheel1

Filter	1	2	3	4	5	6	7	8
Transmittance	1	0	0.9	0.5	0.1	0.01	0.001	0.0001

Wheel2

Filter	9	10	11	12	13	14	15	16
Transmittance	1	0	0.8	0.3	0.03	0.003	0.0003	3e-05

Default file location

Restore from flash Restore from file...

Save to flash Save to file...

Compare two files

Reset OK Cancel Apply

Attenuator settings tab

This tab is used to configure attenuator interface. An attenuator is a device used to reduce the power level of an optical signal by passing light through one or several optical filters. This tab becomes active when an "Attenuator" skin type is selected in "Program configuration" tab.

Attenuator type group contains radio buttons which allow one to choose one- or two-wheel configuration of the attenuator. Depending on the choice here one or two **Wheel** groups become available. They should be filled with attenuator filters' transparency values on the corresponding wheel, in order.

5.4.4. Cyclical motion settings

In the [Application Settings](#) **Program configuration** -> **Cyclic motion**

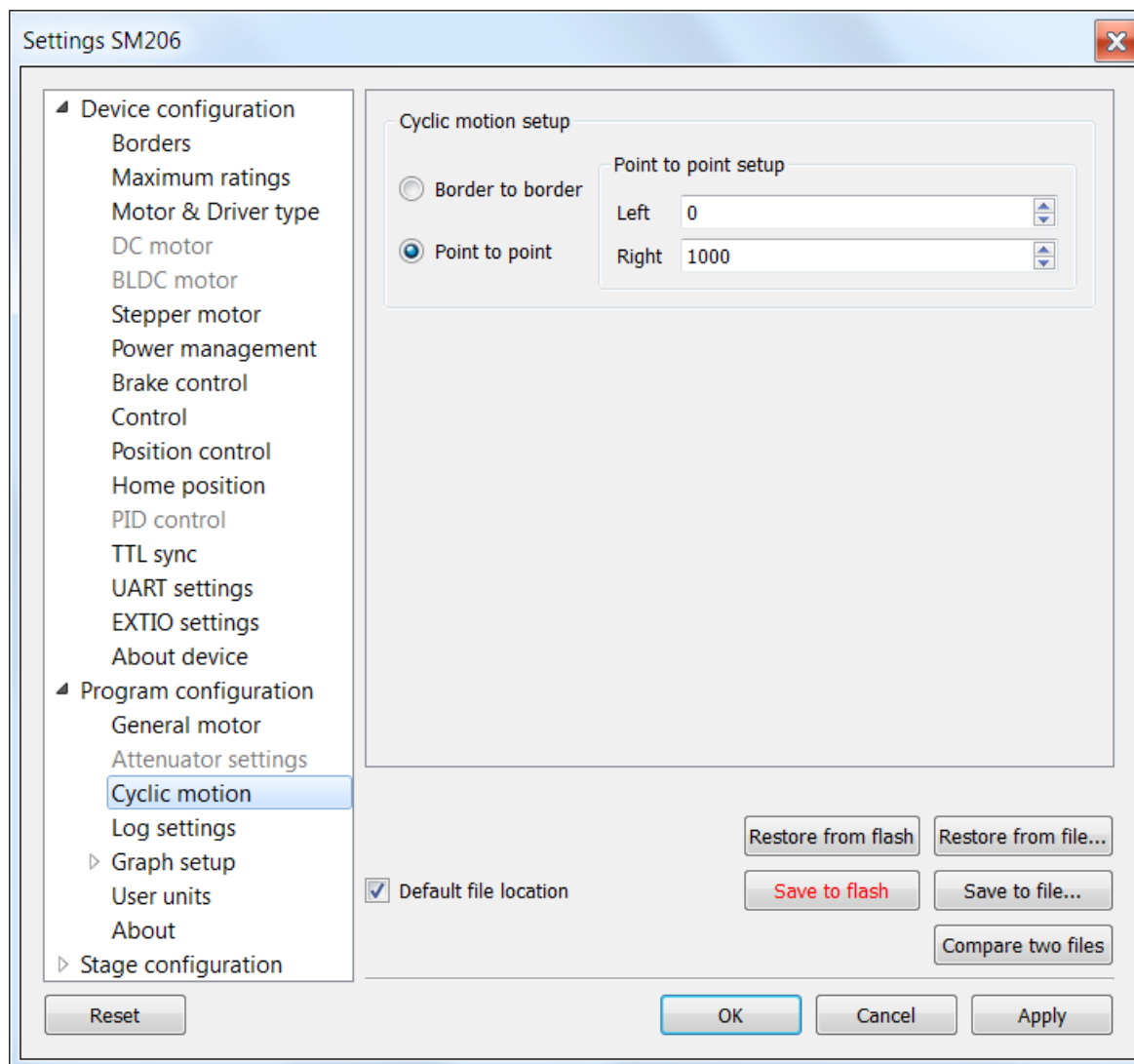

Cyclic motion tab

Use this tab to configure the cyclic motion between two preset positions. It is used mainly for demonstration purposes. This mode is activated by [Cyclic](#) button in the [main window](#), and deactivated by [Stop](#) button in the [main window](#).

Cyclic motion mode settings:

Border to border - cyclical motion between the borders configured in the [Motion range and limit switches](#). The motion begins towards the left edge.

Point to point - cyclical motion between points specified in the [Point to point setup](#) group. The stage moves to the left point, stops, then moves to the right point, stops, and then the cycle repeats.

5.4.5. Log settings

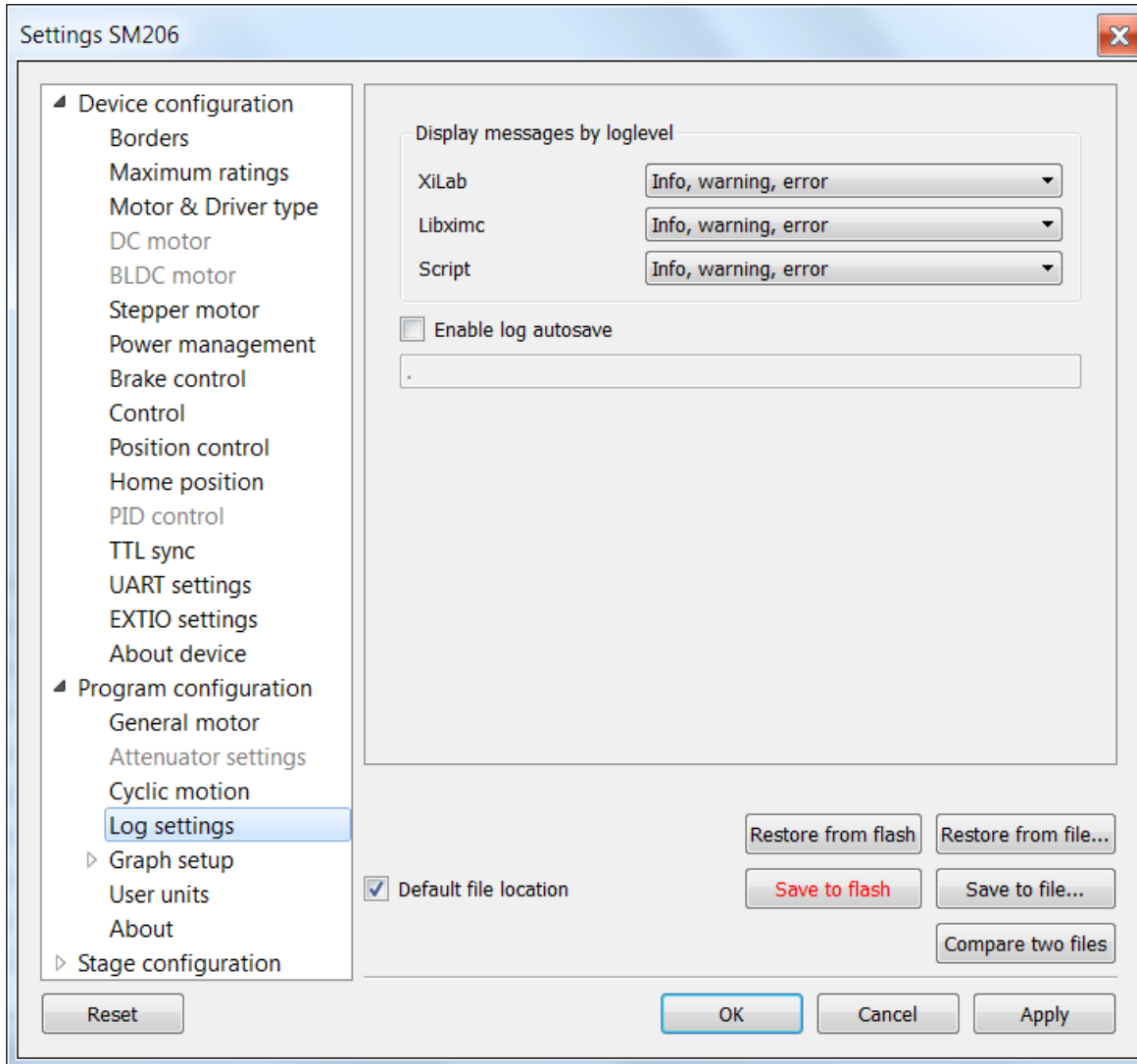

XiLab log settings window

On this page (Program configuration -> Log settings) you can configure the logging detail level.

In Display messages by loglevel box you can choose an option to log nothing (None), log only errors (Error), errors and warning messages (Error, Warning), errors, warnings and information messages (Error, Warning, Info) for each source: XiLab application, libximc library and Scripts module.

If the Enable log autosave checkbox is checked then the log is saved into file. Directory where the log file will be saved is set below. Log file is flushed to the disk every 5 seconds.

File has a name of type "xilab_log_YYYY.MM.DD.csv", where YYYY, MM and DD are current year, month and day, respectively. Data is stored in CSV format. Messages that are saved into the log file are not filtered by logging options.

5.4.6. Charts general settings

Program configuration -> Graph setup in the [Application Settings](#)

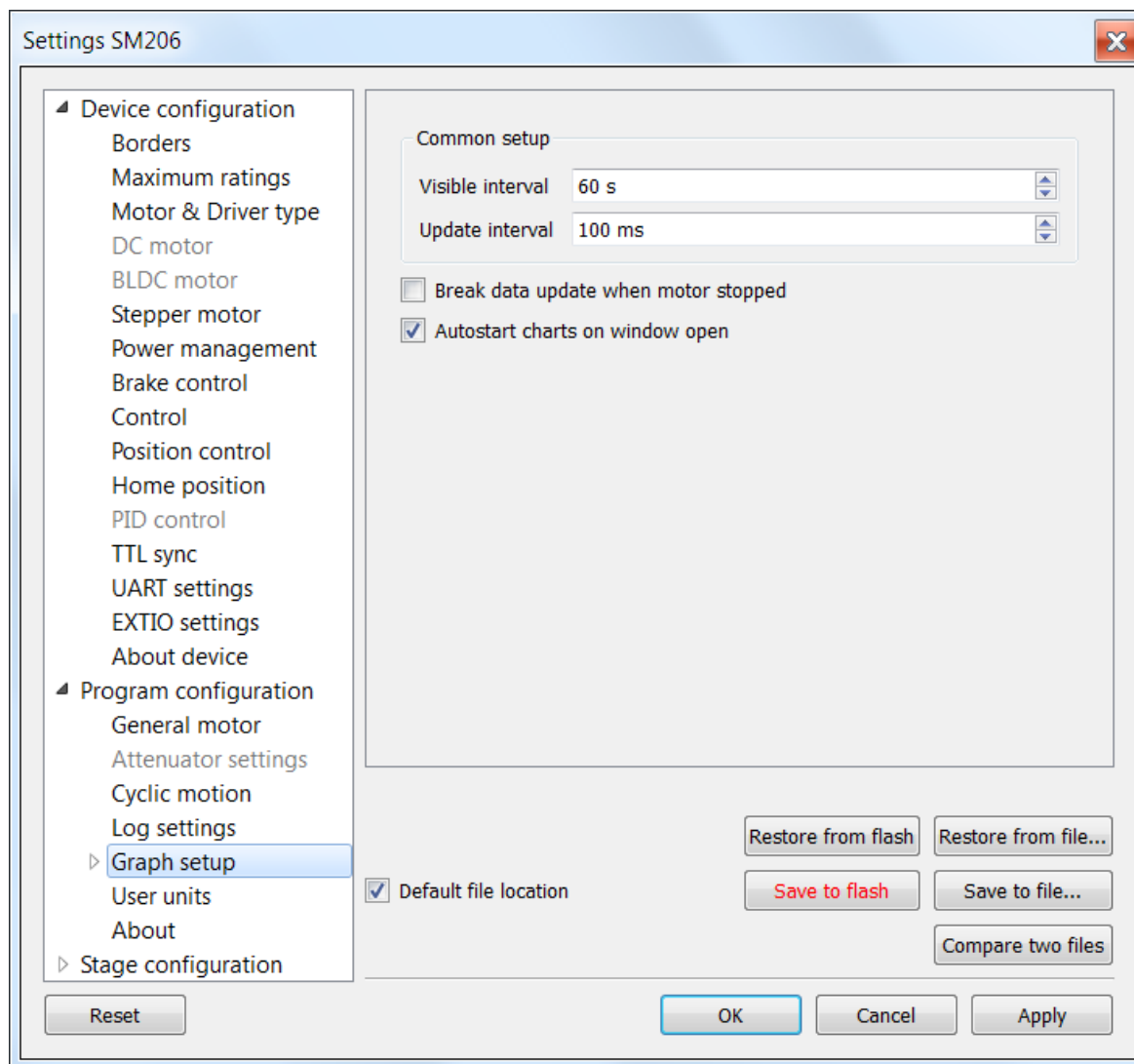

Charts general settings tab

Visible interval - the time interval displayed in charts on the horizontal axis.

Update interval - chart data update interval.

Break data update when motor stopped - stops drawing charts when the motor stops. This option provides the possibility to use the chart space more rationally, removing the areas when there is no motor motion.

Autostart charts on window open - starts displaying chart data automatically on window open. If you wish to start charts update manually, then uncheck this option.

5.4.7. Charts customization

In the [Application Settings](#) **Program configuration** -> **Graph setup** -> ...

This section equally applies to the individual appearance settings of speed, voltage, current, PWM duty factor, temperature, and other parameter charts, which can be displayed in the XILab application.

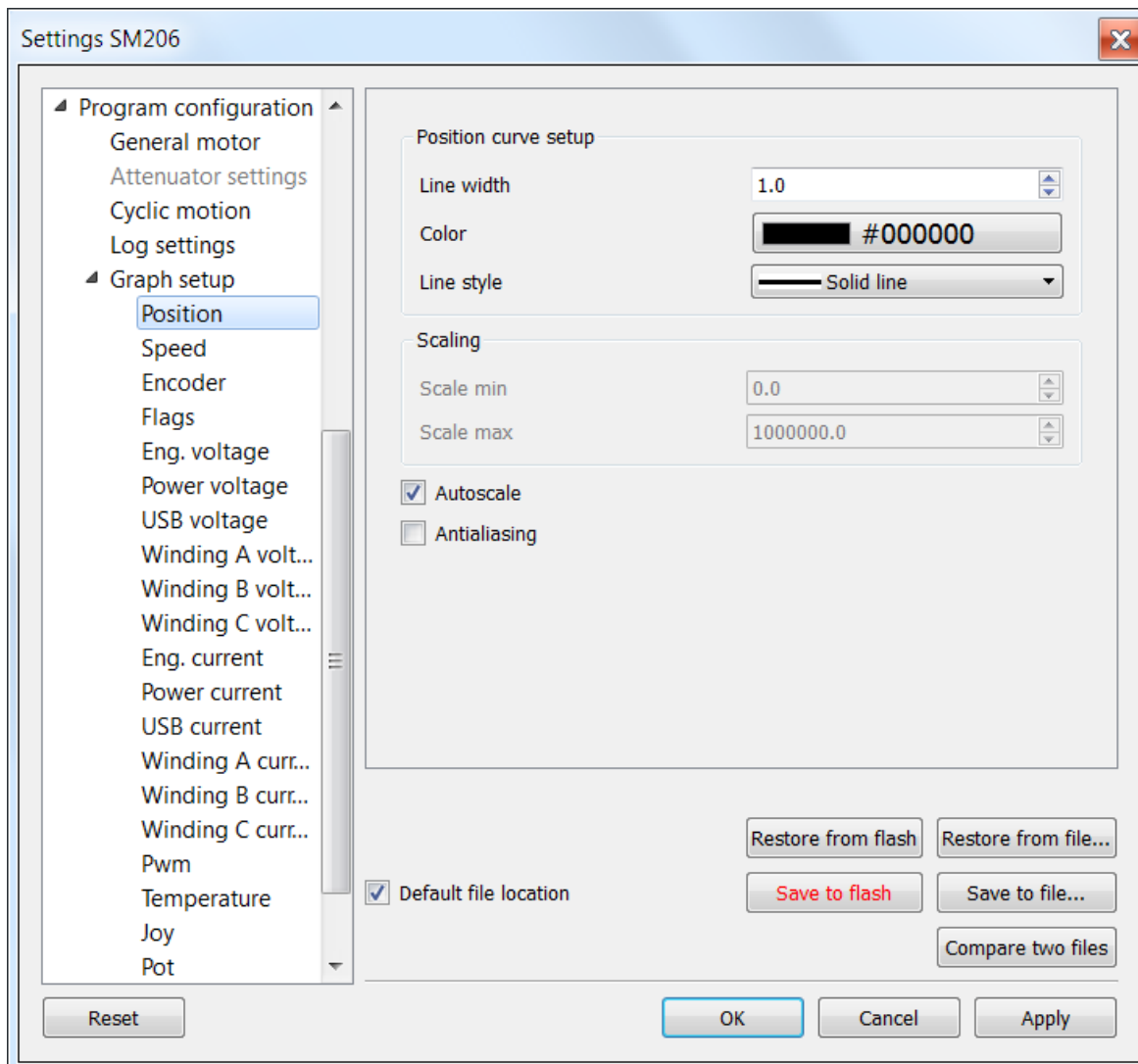

Charts customization on the example of the position chart tab

Charts display settings include line style and chart vertical axis scale adjustment.

Position curve setup group changes curve parameters. It includes the [Line width](#), [Color](#) and [Line style](#).

Scaling group changes curve display range on the vertical axis by setting values in [Scale min](#) and [Scale max](#).

Checked [Autoscale](#) flag results in auto-scaling of the scale limits in accordance with the change limits of the variable on the axis Y. In this case, the parameters [Scale min](#) and [Scale max](#) are ignored.

[Antialiasing](#) flag enables chart lines smoothing, which provides the possibility to achieve a higher-quality display, but it slows a little the chart drawing process.

5.4.8. User units settings

In the [Application Settings](#) **Program configuration** -> **User units**

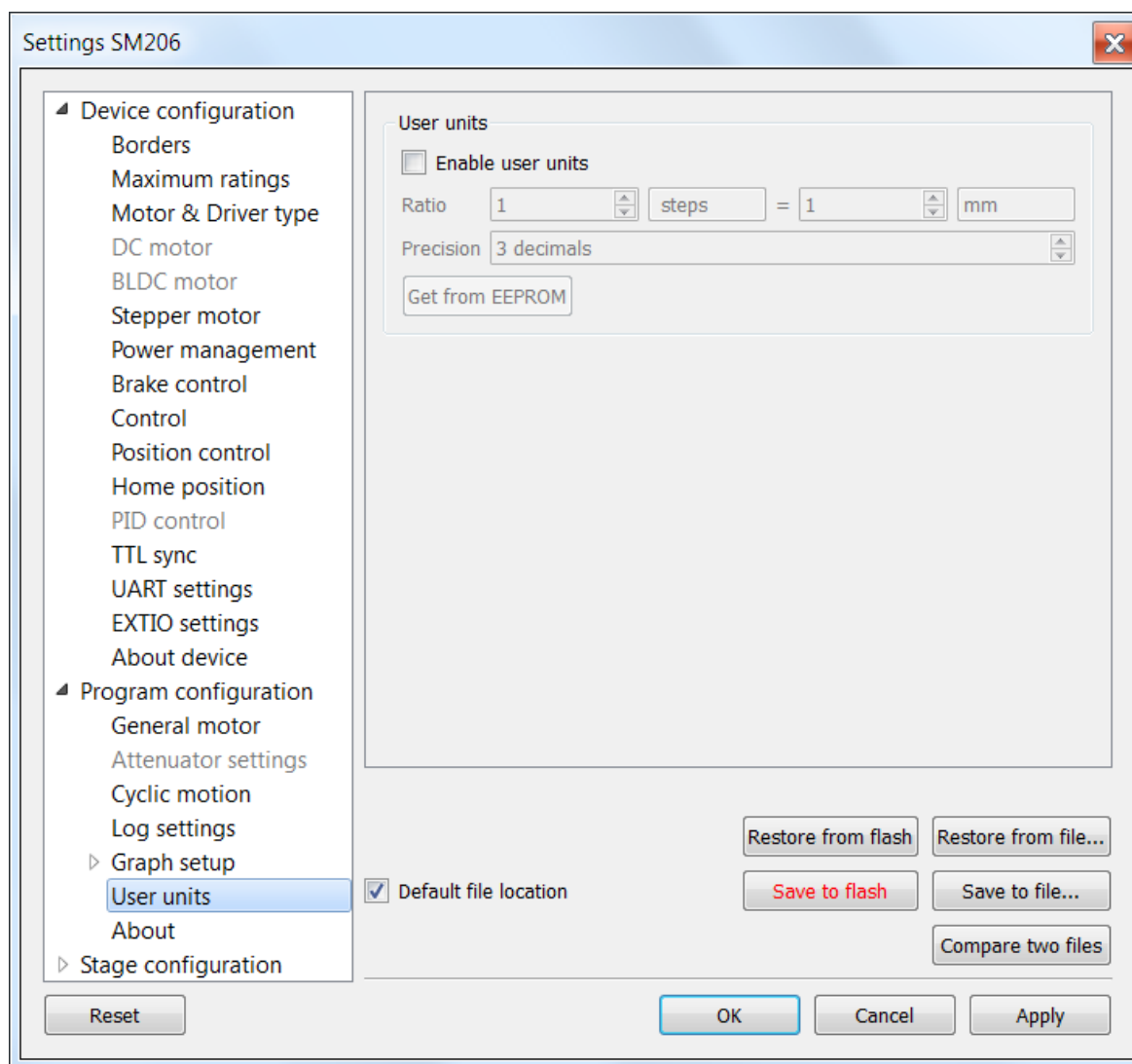

User units tab

Use this tab to configure user units display. Used to replace internal controller coordinates with units familiar to the user.

User units settings:

Enable user units - enables user unit display instead of steps (in case of stepper motor) or encoder counts (in case of DC motor). User units replace steps(counts) only in the main XILab window and do not affect any of the Settings pages.

Ratio - conversion of controller steps to position units, set as a ratio of two integer values "x steps = y user units". Values "x", "y" and unit name string are set by user.

Precision - displayed precision.

Get from EEPROM button reads user unit settings from connected EEPROM.

5.4.9. About the application

Program configuration -> **About** in the [Application Settings](#)

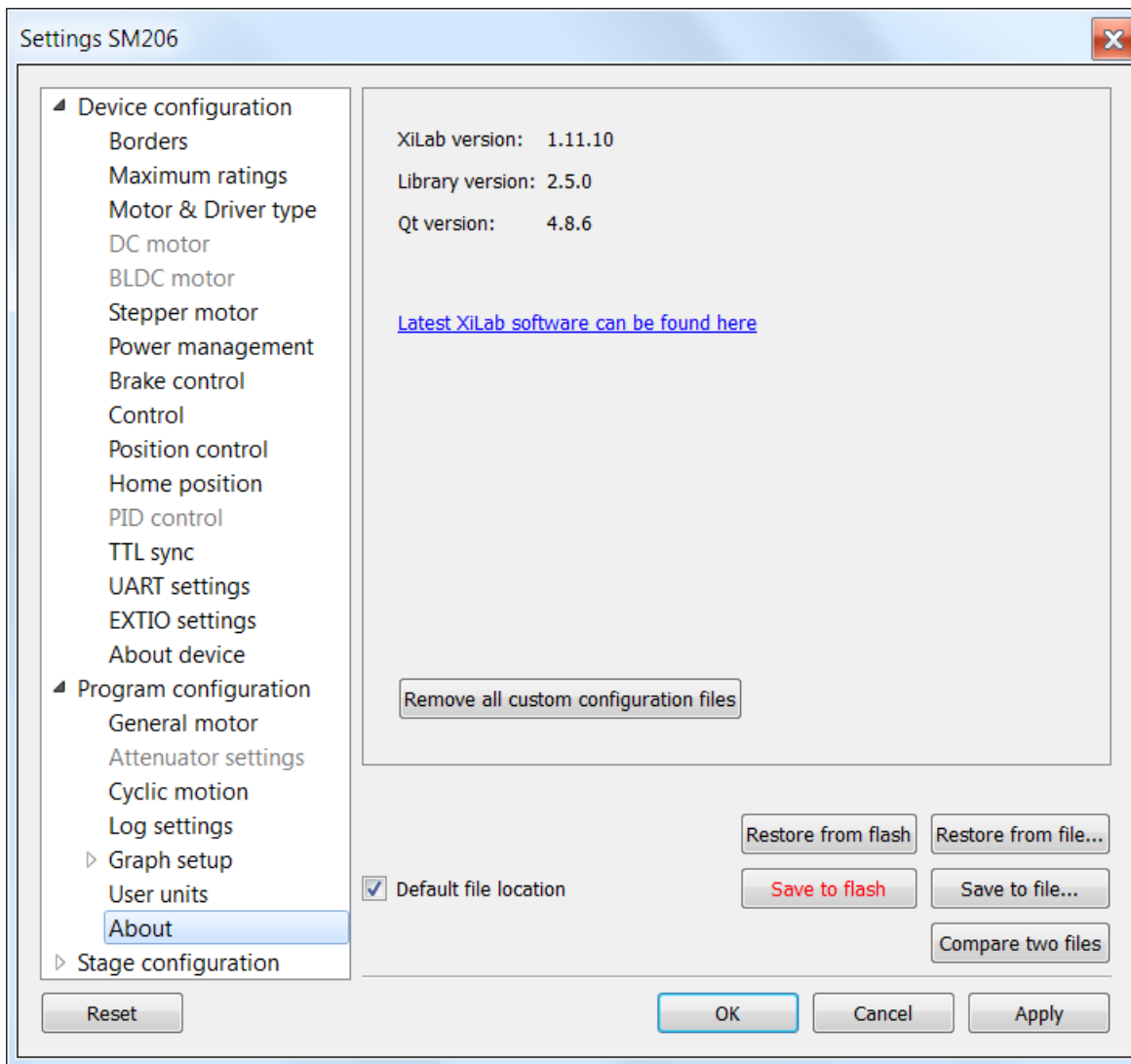

About tab

This section displays the XiLab application version. It also contains a link to the page with the latest [Software](#) version.

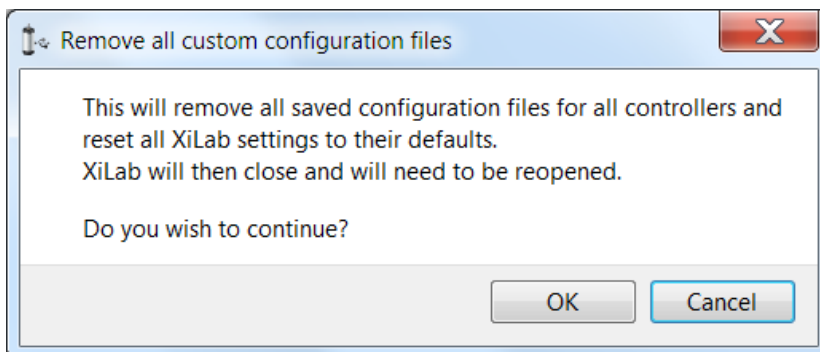

User configuration file cleanup dialog

"Remove all custom configuration files" button displays a dialog prompt to delete all custom configuration files created by XiLab. Files to be deleted are located in XiLab configuration directory. These files are "settings.ini", which stores common program settings, "SNnnn.cfg", which store per-controller settings, "V_nnn", which store virtual controller internal states, "scratch.txt", which stores last run [script](#). Here "nnn" means any number. Pressing OK in this dialog will delete all these files and close XiLab, pressing Cancel will abort deletion and close this dialog.

5.5. Positioner specifications

1. [Positioner name](#)
2. [Positioner general characteristics](#)
3. [Motor characteristics](#)
4. [Encoder specifications](#)
5. [Hall sensor characteristics](#)
6. [Reducing gear specifications](#)
7. [Accessories specifications](#)

5.5.1. Positioner name

Stage configuration -> **Positioner name** in the [Application Settings](#)

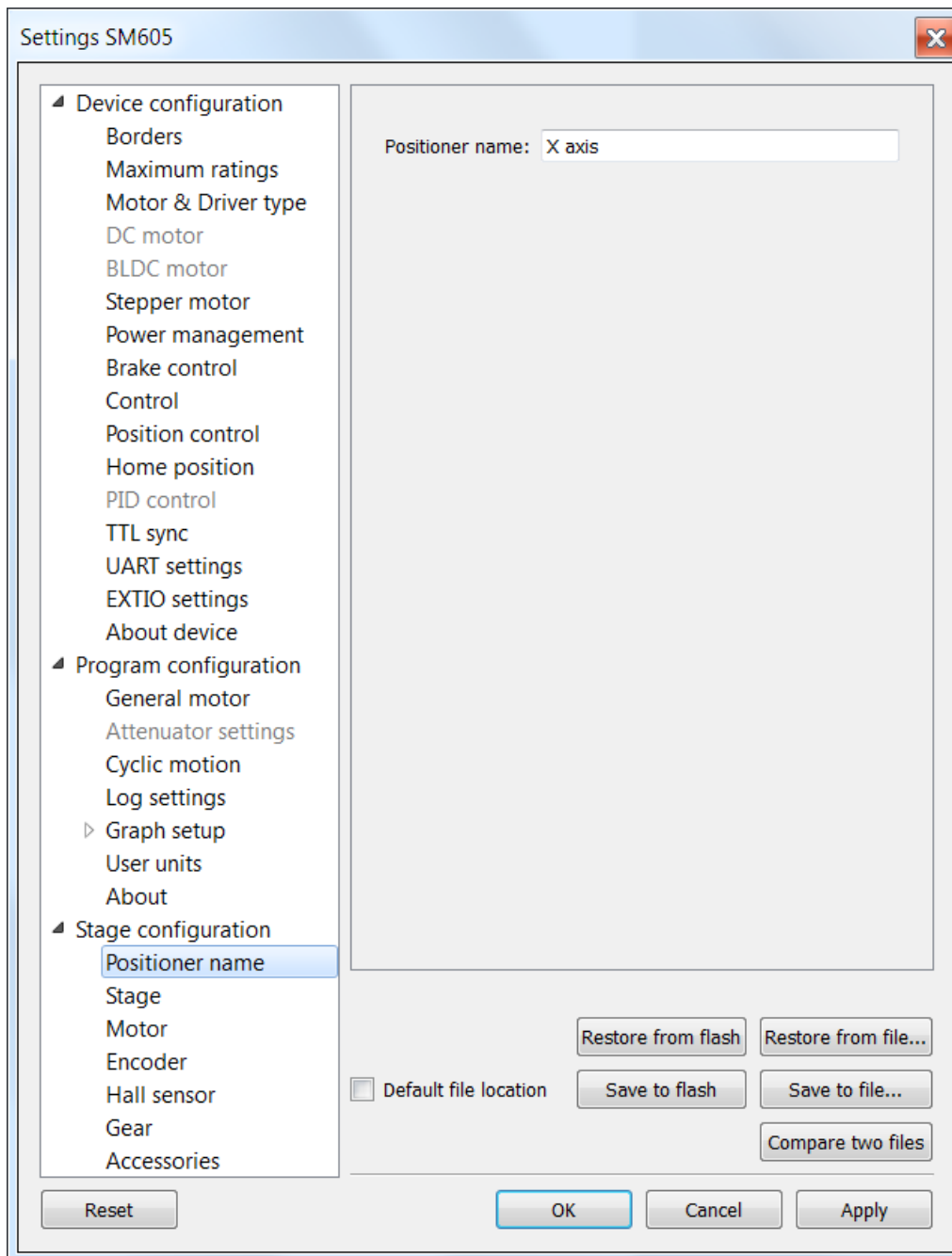

Positioner name window

This block contains the positioner name (defined by user).

5.5.2. Positioner general characteristics

Stage configuration -> **Stage** in the [Application Settings](#)

Settings SM605

- ▲ Device configuration
 - Borders
 - Maximum ratings
 - Motor & Driver type
 - DC motor
 - BLDC motor
 - Stepper motor
 - Power management
 - Brake control
 - Control
 - Position control
 - Home position
 - PID control
 - TTL sync
 - UART settings
 - EXTIO settings
 - About device
- ▲ Program configuration
 - General motor
 - Attenuator settings
 - Cyclic motion
 - Log settings
 - ▷ Graph setup
 - User units
 - About
- ▲ Stage configuration
 - Positioner name
 - Stage**
 - Motor
 - Encoder
 - Hall sensor
 - Gear
 - Accessories

Manufacturer: Standa

Part number: 8CMA06-13-10

Lead screw pitch: 0.25 mm

Units: mm

Max. speed: 6 mm/s

Travel range: 13 mm

Supply voltage: 12 V - 36 V

Max. current consumption: 0 A

Horizontal load capacity: 0 kg

Vertical load capacity: 0 kg

Default file location

Restore from flash Restore from file...
 Save to flash Save to file...
 Compare two files

Reset OK Cancel Apply

Positioner general characteristics window

Stage parameter group contains information about the stage.

Manufacturer - the manufacturer name.

Part number - the catalog number.

Lead screw pitch - lead screw pitch.

Units - stage movement measurement units (mm, degrees, steps).

Max. speed - the maximum speed.

Travel range - range of motion.

Supply voltage - acceptable supply voltage range.

Max. current consumption - the maximum current consumption.

Horizontal load capacity - the maximum horizontal load on the stage.

Vertical load capacity - the maximum vertical load on the stage.

5.5.3. Motor characteristics

Stage configuration -> **Motor** in the [Application Settings](#)

Settings SM605

- Device configuration
 - Borders
 - Maximum ratings
 - Motor & Driver type
 - DC motor
 - BLDC motor
 - Stepper motor
 - Power management
 - Brake control
 - Control
 - Position control
 - Home position
 - PID control
 - TTL sync
 - UART settings
 - EXTIO settings
 - About device
- Program configuration
 - General motor
 - Attenuator settings
 - Cyclic motion
 - Log settings
 - Graph setup
 - User units
 - About
- Stage configuration
 - Positioner name
 - Stage
 - Motor**
 - Encoder
 - Hall sensor
 - Gear
 - Accessories

Manufacturer: Nanotec

Part number: ST2018SO604

Motor type: Stepper

Poles: 0

Phases: 0

Nominal voltage: 3.9 V

Nominal current: 0.6 A

Nominal speed: 0 rpm

Nominal torque: 0.018 mN m

Nominal power: 0 W

Winding resistance: 6.5 Ohm

Winding inductance: 1.7 mH

Rotor inertia: 2 g cm²

Stall torque: 0 mN m

Detent torque: 0 mN m

Torque constant: 0 mN m / A

Speed constant: 0 steps/s / V

Speed / torque gradient: 0 rpm / m Nm

Mechanical time constant: 0 ms

Max speed: 0 steps/s

Max current: 0 A

Max current time: 0 ms

No load current: 0 A

No load speed: 0 rpm

Default file location

Restore from flash Restore from file...

Save to flash Save to file...

Compare two files

Reset OK Cancel Apply

Motor characteristics window

This section contains motor information.

Manufacturer - motor manufacturer.

Part number - catalog number.

Motor type - motor type (stepper, DC or BLDC)

Poles - number of pole pairs for DC or BLDC motors, steps per revolution for stepper motors.

Phases - BLDC motor phases.

Nominal voltage - nominal winding voltage.

Nominal current - maximum continuous winding current for DC or BLDC motors, nominal current for stepper motors.

Nominal speed - nominal speed.

Nominal torque - nominal torque.

Nominal power - nominal power consumption.

Winding resistance - active resistance of the winding.

Winding inductance - inductance of the winding.

Rotor inertia - rotor inertia.

Stall torque - zero speed torque.

Detent torque - hold torque with unpowered windings.

Torque constant - torque constant.

Speed constant - speed constant.

Speed/torque gradient - speed/torque constant.

Mechanical time constant - motor time constant.

Max speed - maximum allowed speed.

Max current - maximum allowed winding current.

Max current time - maximum safe time of max current in the winding.

No load current - no-load current consumption.

No load speed - no-load motor speed.

5.5.4. Encoder specifications

Stage configuration -> **Encoder** in the [Application Settings](#)

Settings SM605

▲ Device configuration
 Borders
 Maximum ratings
 Motor & Driver type
 DC motor
 BLDC motor
 Stepper motor
 Power management
 Brake control
 Control
 Position control
 Home position
 PID control
 TTL sync
 UART settings
 EXTIO settings
 About device
 ▲ Program configuration
 General motor
 Attenuator settings
 Cyclic motion
 Log settings
 ▸ Graph setup
 User units
 About
 ▲ Stage configuration
 Positioner name
 Stage
 Motor
Encoder
 Hall sensor
 Gear
 Accessories

Manufacturer:
 Part number:
 Max. operating frequency: 0 kHz
 Supply voltage: 0 V - 0 V
 Max. current consumption: 0 mA
 Pulses per revolution: 0
 Output: Single ended
 Output type: Push-pull
 Index channel:
 Revolution sensor:
 Rev.sensor active is high:

Default file location

Window Encoder specifications

This section contains information about [encoder](#)

Manufacturer - encoder manufacturer name.

Part number - the catalog number.

Max. operating frequency - the maximum operating frequency.

Supply voltage - acceptable supply voltage range.

Max. current consumption - the maximum current consumption.

Pulses per revolution - pulses per single motor shaft revolution.

Output - differential or single-ended output.

Output type - electric output type (push-pull or open drain).

Index channel - indicates if additional index channel is present.

Revolution sensor - indicates if revolution sensor is present.

Rev.sensor active is high - if enabled then active revolution sensor state is logical 1, else it is logical 0.

5.5.5. Hall sensor characteristics

Stage configuration -> **Hall sensor** in the [Application Settings](#)

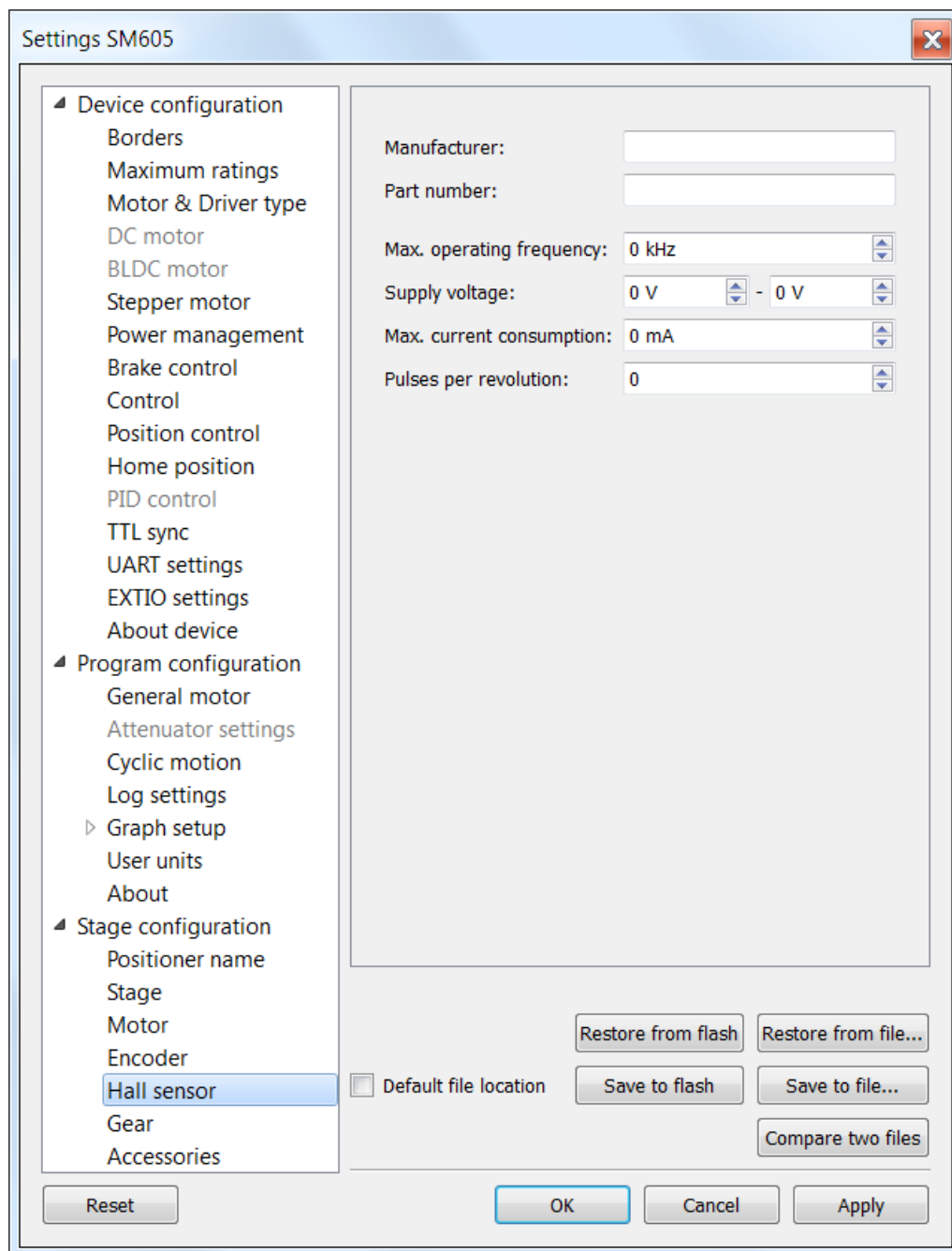

Hall sensor properties window

This section contains information about hall sensor:

Manufacturer - sensor manufacturer name.

Part number - the catalog number.

Max. operating frequency - the maximum operating frequency.

Supply voltage - acceptable supply voltage range.

Max. current consumption - the maximum current consumption.

Pulses per revolution - pulses per single motor shaft revolution.

5.5.6. Reducing gear specifications

Stage configuration -> **Gear** in the [Application Settings](#)

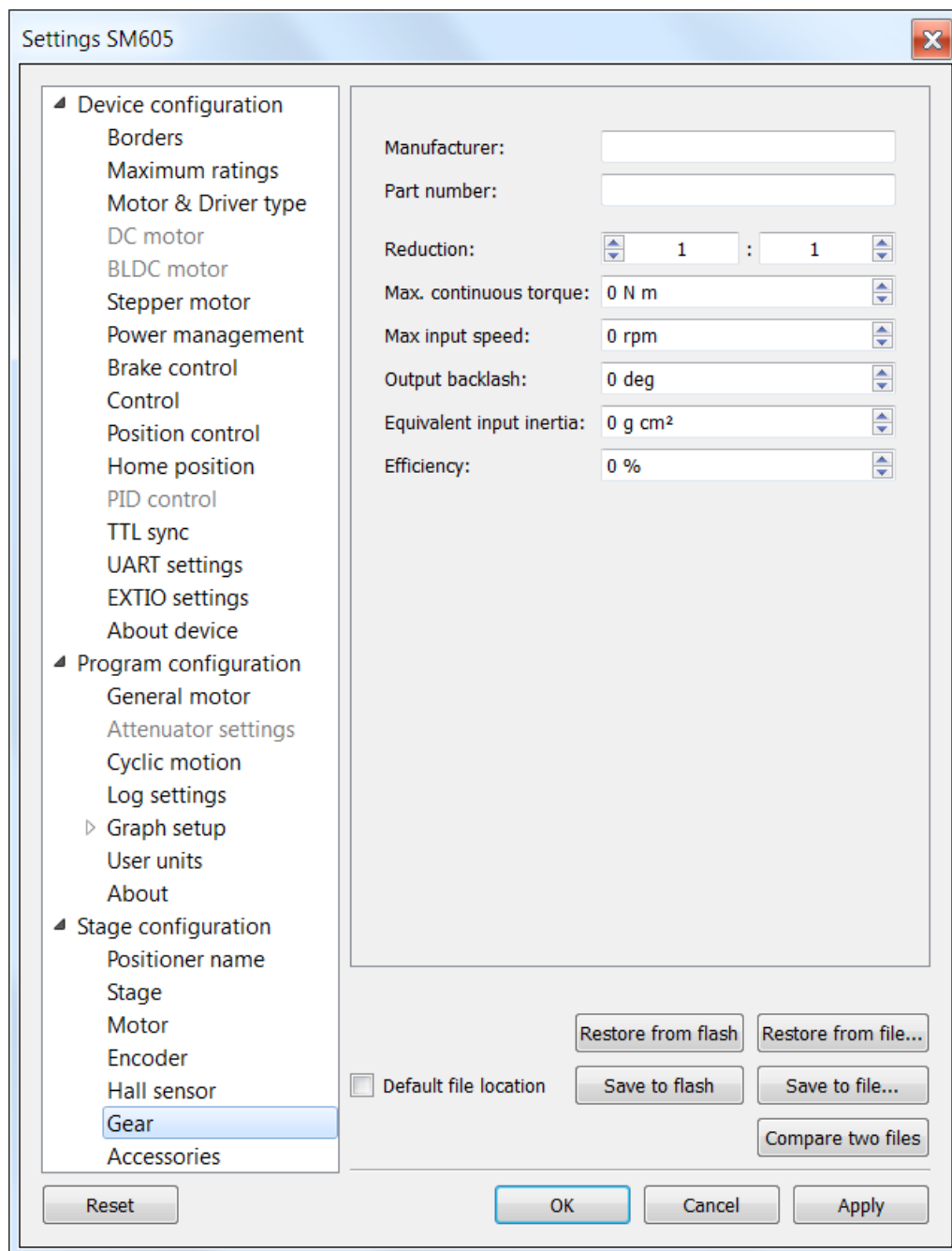

Reducing gear specifications window

This section contains information about the reducing gear.

Manufacturer - the manufacturer name.

Part number - the catalog number.

Reduction - gear transmission ratio.

Max. continuous torque - maximum torque at the gear input.

Max. input speed - the maximum speed at the gear input.

Output backlash - gear output backlash.

Equivalent input inertia - equivalent input inertia of the gear.

Efficiency - Gear efficiency.

5.5.7. Accessories specifications

Stage configuration -> **Accessories** in the [Application Settings](#)

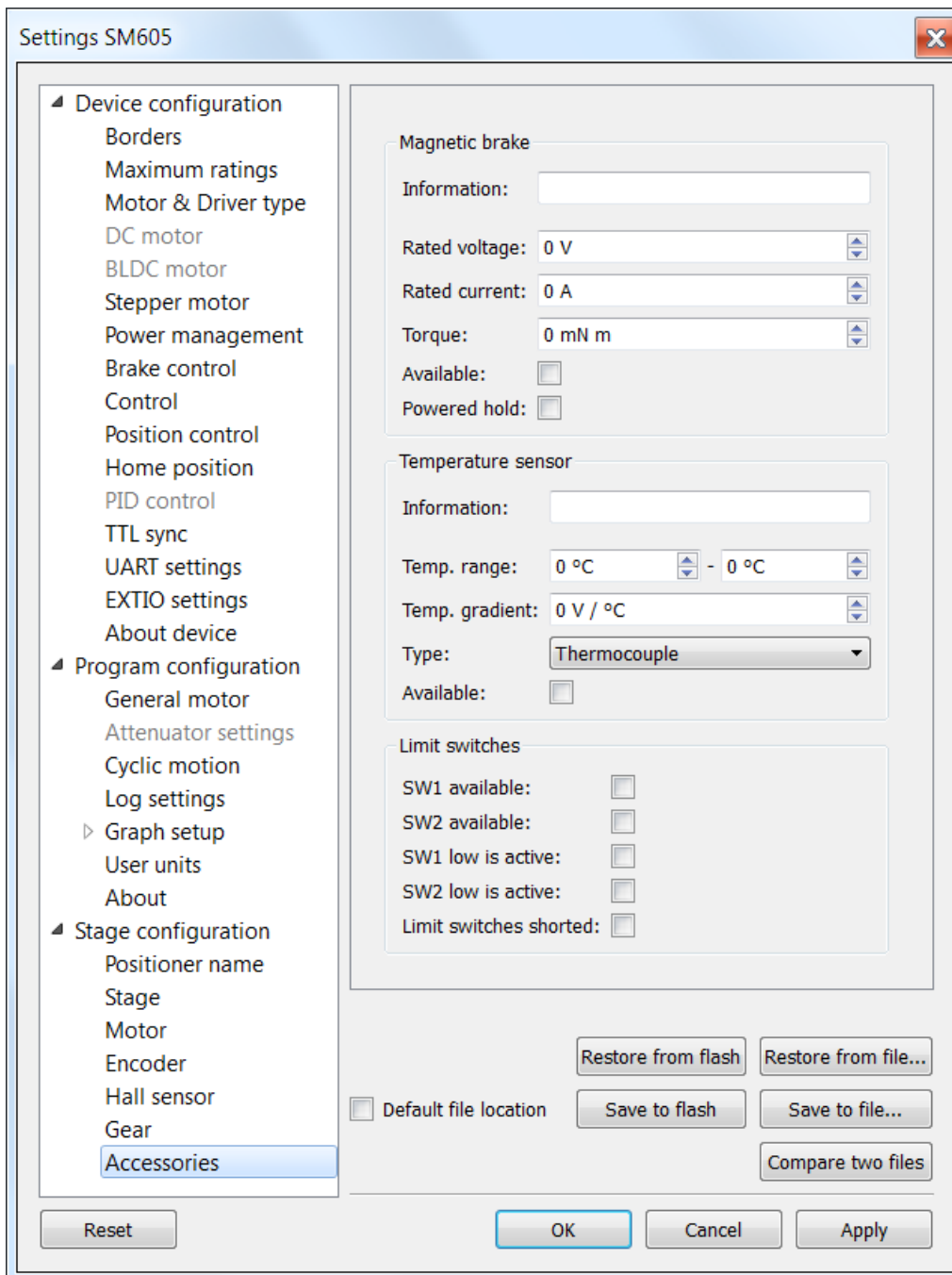

Accessories specifications window

This panel contains information about various accessories.

Magnetic brake - magnetic brake section.

Information - magnetic brake manufacturer and part number.

Rated voltage - nominal magnetic brake voltage.

Rated current - nominal magnetic brake current.

Torque - hold torque.

Available - indicates if magnetic brake is available.

Powered hold - magnetic brake is in hold mode on power on if this option is enabled.

Temperature sensor - temperature sensor section.

Information - temperature sensor manufacturer and part number.

Temp. range - measured temperature range.

Temp. gradient - temperature gradient.

Type - sensor type (thermocouple or semiconductor).

Available - indicates if temperature sensor is available.

Limit switches - limit switches section.

SW1 available - indicates if SW1 limit switch is available.

SW2 available - indicates if SW2 limit switch is available.

SW1 low is active - indicates if SW1 limit switch active state is low.

SW2 low is active - indicates if SW2 limit switch active state is low.

Limit switches shorted - if enabled, then limit switches are shorted.

5.6. Correct shutdown

Correct shutdown assumes shutdown of the motor and saving the current position by the controller. The current position is automatically saved, see [Saving the position in controller's FRAM memory](#).

Exit button performs correct shutdown and exit. When you click it the application sends a soft stop command to the controller, and after the stop is complete, the application sends command of power-off. If execution of the soft stop command was interrupted by an event like a motion command from the [joystick](#) or signal of [TTL synchronization](#), or if while sending of soft stop command or command of power off to the controller, the library returned an error, the exit will be canceled. In this case you need to check [joystick settings and settings of "right" and "left" buttons](#) and [Synchronization settings](#).

5.7. Working over network

XiLab is capable of interacting with remote controllers via Ethernet. However you need a special XIMC server, which can be either obtained as a standalone program and installed on any appropriate device, or as one of the services of **8SMC4-USB-Eth1** adapter.

Getting started

- Before launching, connect controllers to the device with XIMC server installed using USB cable. At the same time, it is assumed that controllers can be connected to the motor and energized from power supply (see [one axis configuration](#) for more details).
- Connect the device with XIMC server to the same subnet that contains the control computer, DHCP server. In case of **8SMC4-USB-Eth1** adapter supply it with power adapter (via 5V - 2A connector) and wait for a minute to finish Linux boot on the onboard computer.
- Launch XiLab and make the following.

At first start, XiLab opens controller detection window with no devices found.

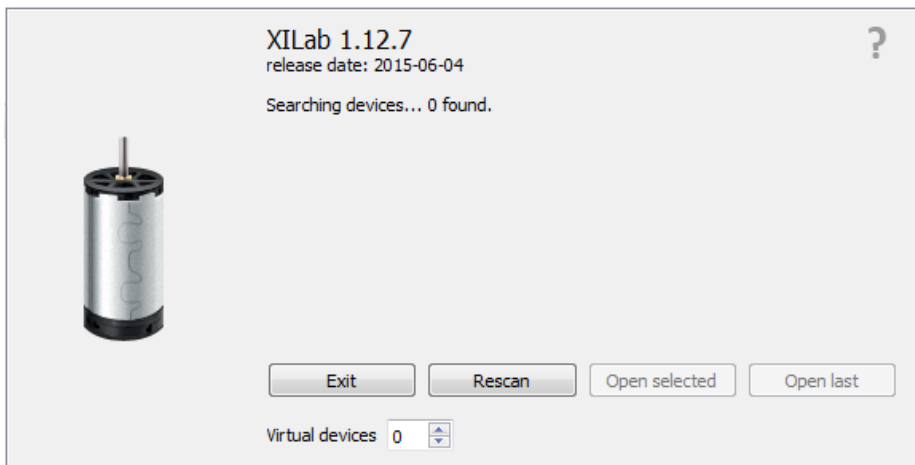

Add virtual XIMC controller by increasing the number of [Virtual Devices](#) in the bottom part of window and click [Rescan](#). Then choose [Virtual XIMC, SN1](#) and click [Open selected](#).

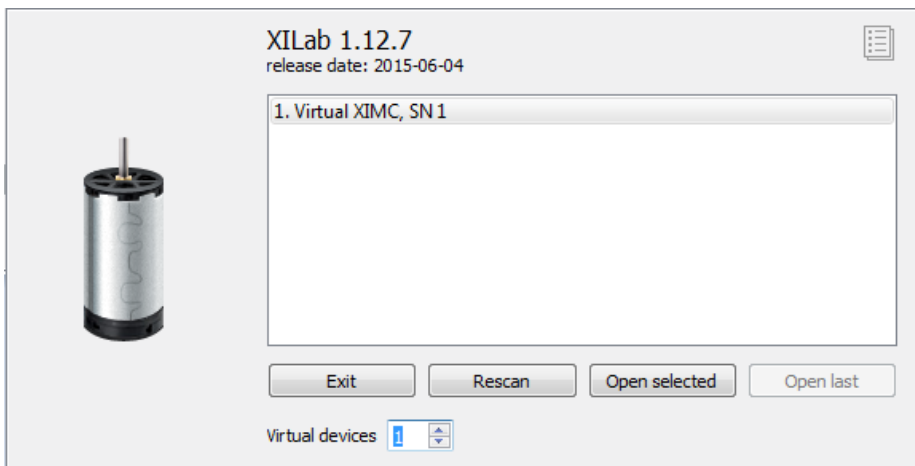

XiLab main window with single axis mode will appear. Go to [Settings...](#) and choose [Program configuration](#) (for detailed information please refer to [XiLab general settings](#)). Check [Enumerate network devices](#) in [Device detection settings](#) and press "Scan for local XIMC servers" button. XiLab will use broadcast request to find available XIMC servers in your LAN and for each detected instance an entry in the "IP/hosts" list will be created. You can also edit address list manually if desired. Click OK and close XiLab.

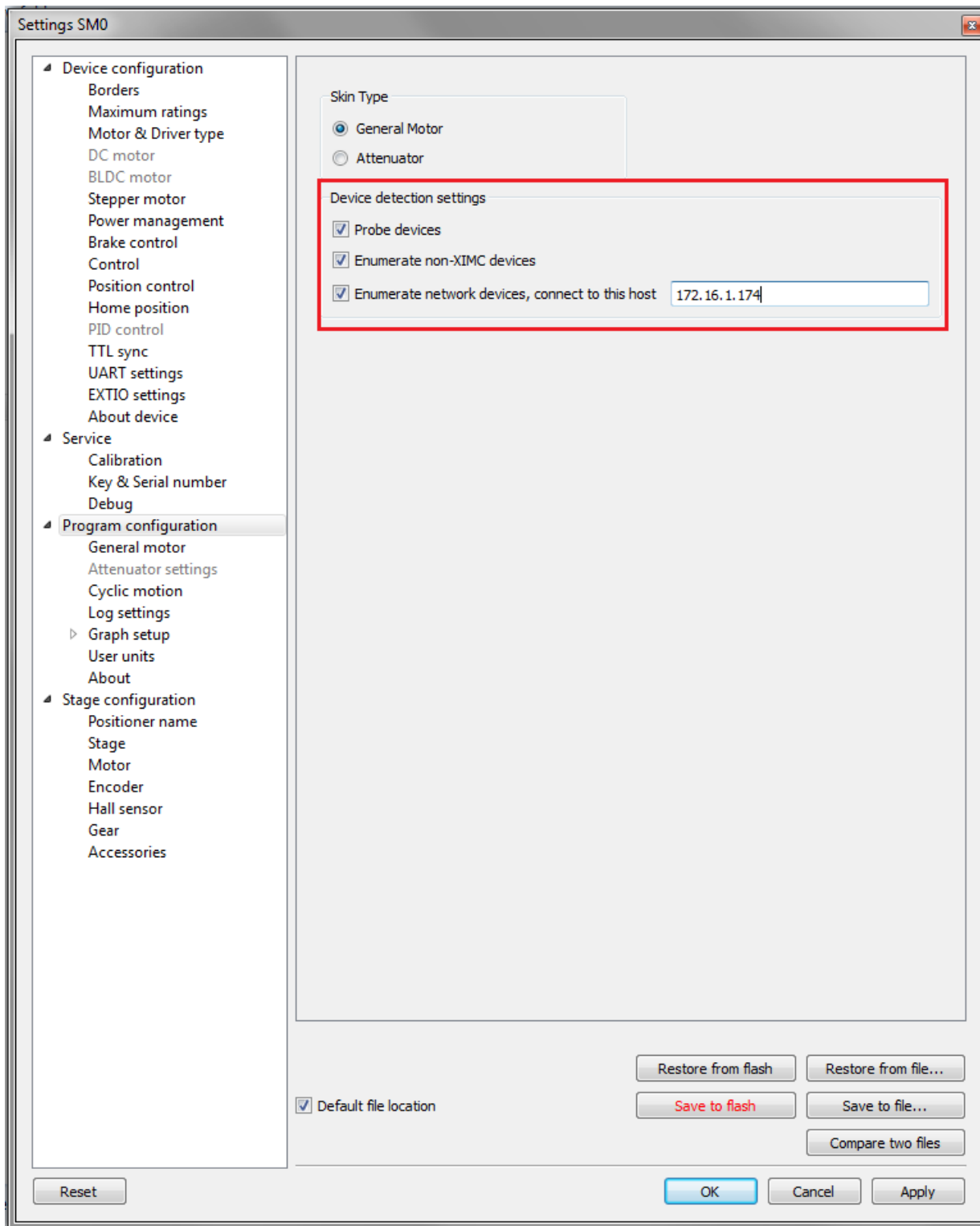

When you restart XiLab it will find all axis connected to the system. In controller detection window choose an axis you need. You can control it in [single-axis mode](#) or in [multi-axis mode](#) if more than one axis was chosen. For additional information please refer to [Getting started with XiLab software](#) and [XiLab application User's guide](#)

Note. Once the device IP address has been found, it should be understood that moving the device to another location may lead to a change in its IP.

Note. Working with multiple adapters may cause a problem when the same board responds in a broadcast requests. You can find a new device by two different ways :

- Disconnect other axes, find the device on the network, connect all again.
- Press Scan for local XIMC servers button until you find sought-for device.

5.8. XILab installation

1. [Installation on Windows](#)
 1. [Installation on Windows XP](#)
 2. [Installation on Windows 7](#)
 3. [Installation on Windows 8](#)
2. [Installation on Linux](#)
3. [Installation on MacOS](#)

5.8.1. Installation on Windows

1. [Installation on Windows XP](#)
2. [Installation on Windows 7](#)
3. [Installation on Windows 8](#)

5.8.1.1. Installation on Windows XP

Copy the installer program file to your computer. The installer file name is "xilab-<version_name>.exe". It automatically detects whether it is running on 32-bit or 64-bit version of Windows and installs the appropriate version of XiLab.

Note: Only Windows XP SP3 is supported. Please update your Windows XP to the latest service pack.

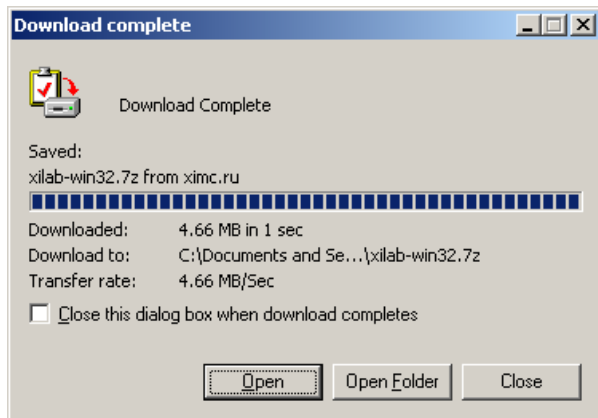
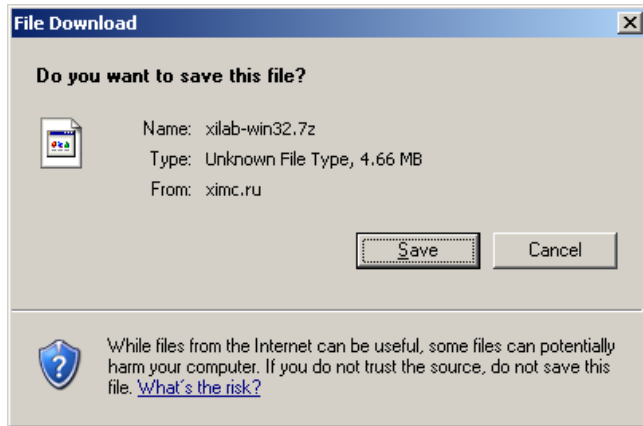

Run the installer and follow the on-screen instructions.

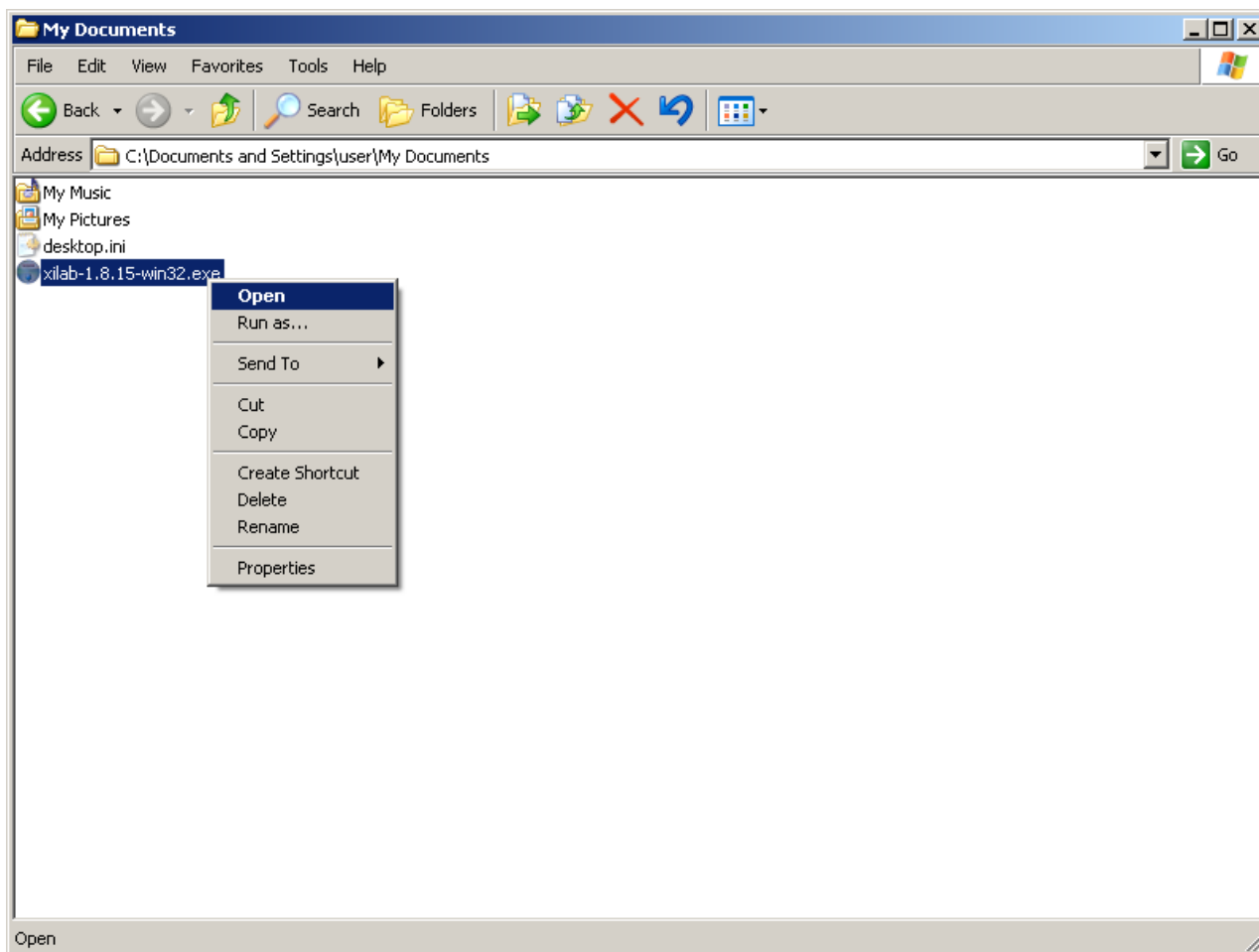

All the necessary software including drivers, packages and programs will be installed automatically.



After the installation is complete the XiLab application will be started by default.

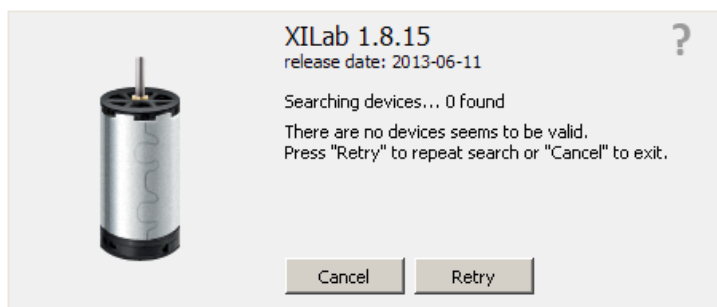

Connect the stage to the controller. Connect regulated power supply to the controller. Ground the controller or the power supply unit. Connect the controller to the computer using a USB-A - mini-USB-B cable.

LED indicator on the controller board will start to flash. New Hardware Wizard will start after the first controller is connected to the computer. Wait until Windows detects the new device and installs the drivers for it.

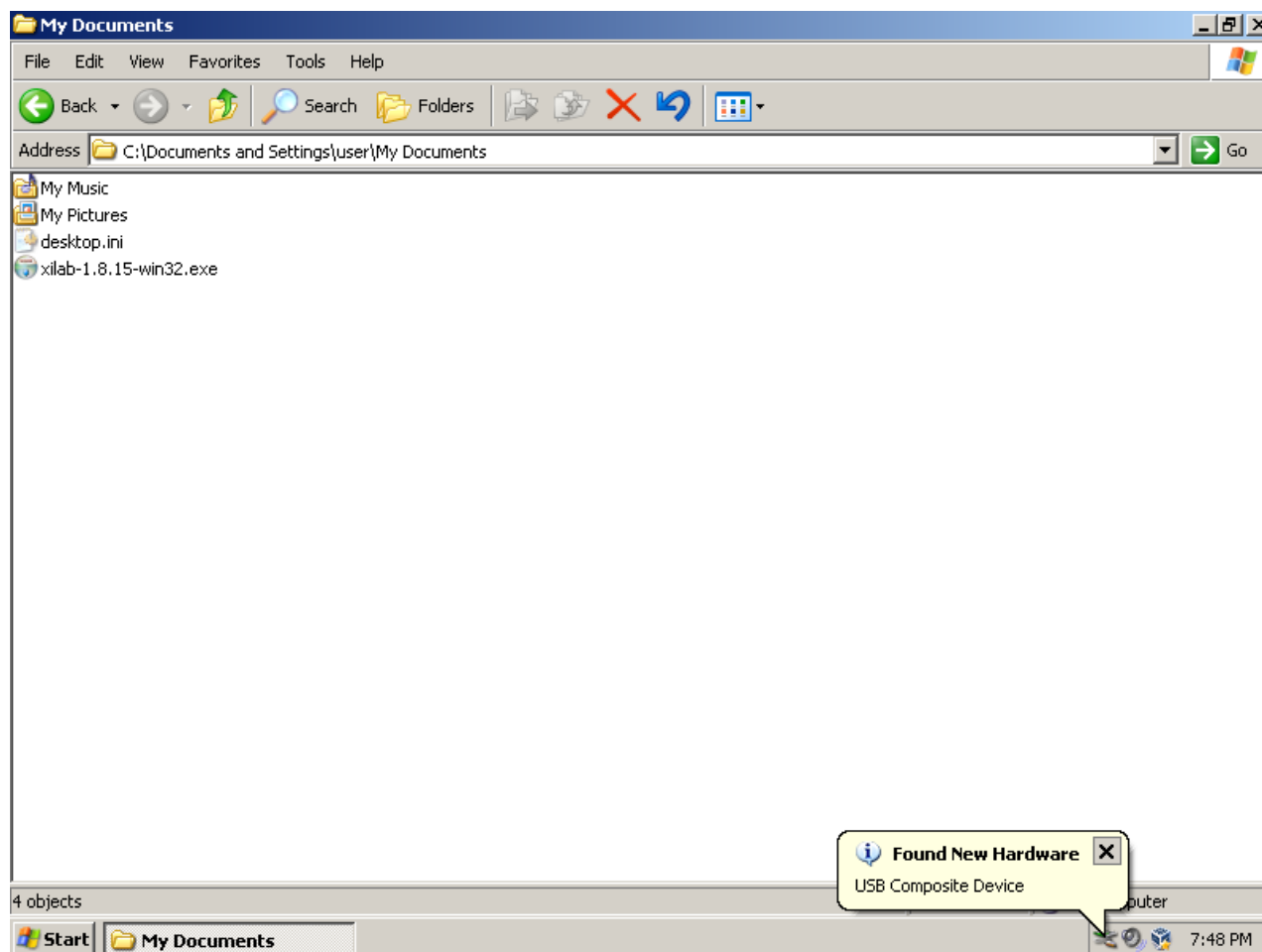

If the driver was not automatically installed select "No, not this time" and click "Next>" in the pop-up window.



In the next window select "Install from a list or specific location (Advanced)" and click "Next>".

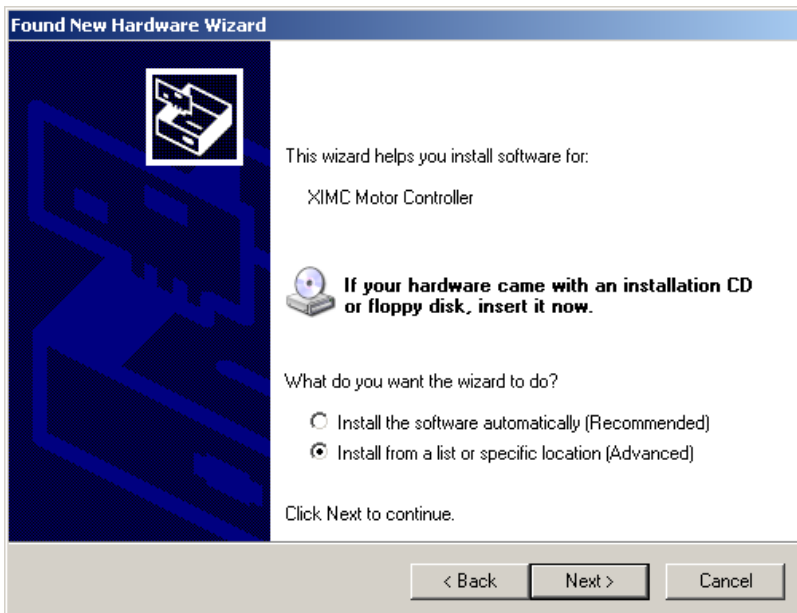

Select the *.inf file on the disk with the software supplied with the controller or in the program directory (by default the path is C:\Program Files\XiLab\driver\) and click "Next".

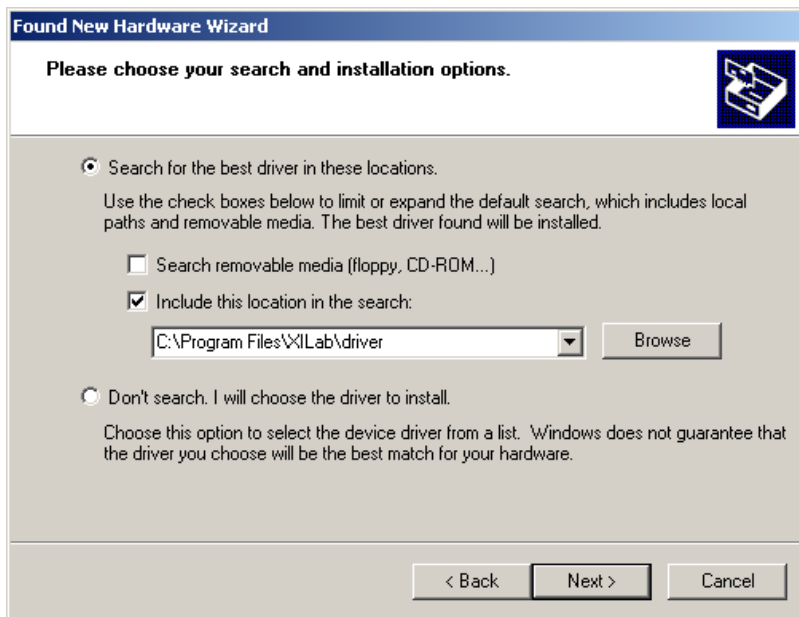

Click "Next".

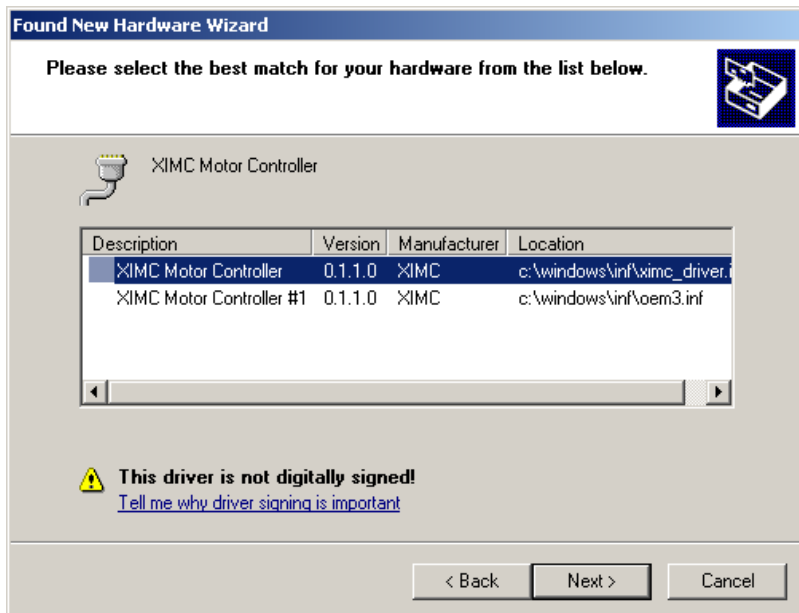

Click "Continue anyway".

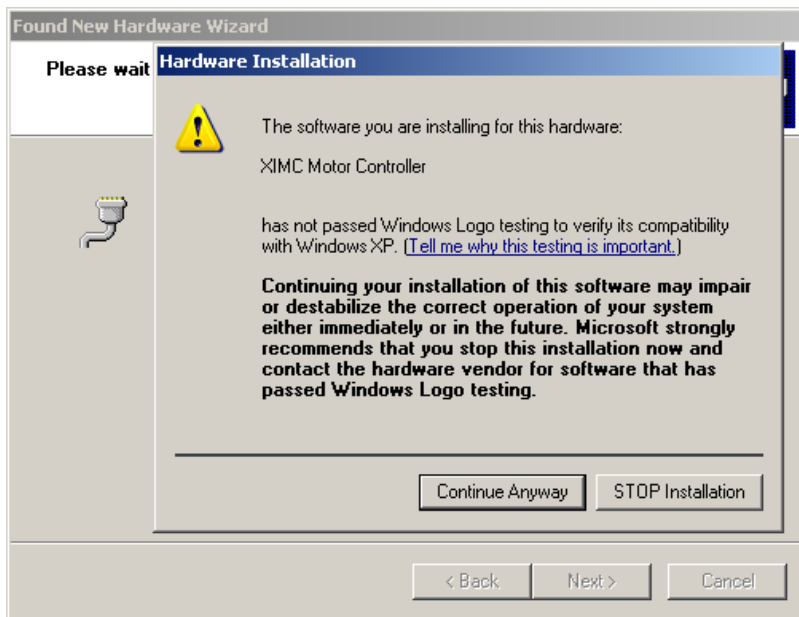

Click "Finish". Driver installation is complete.

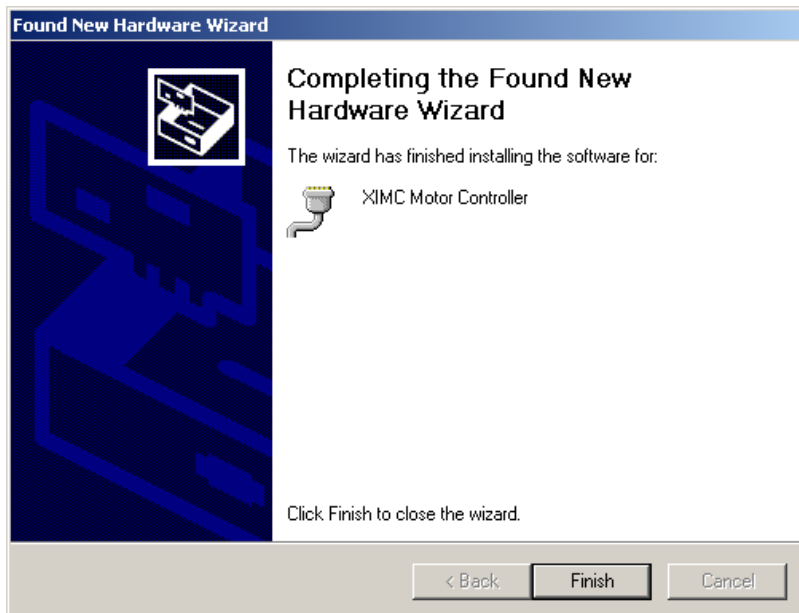

Click Retry or run the Xilab application again if it was closed. The system will detect the connected controller and open the main Xilab window.



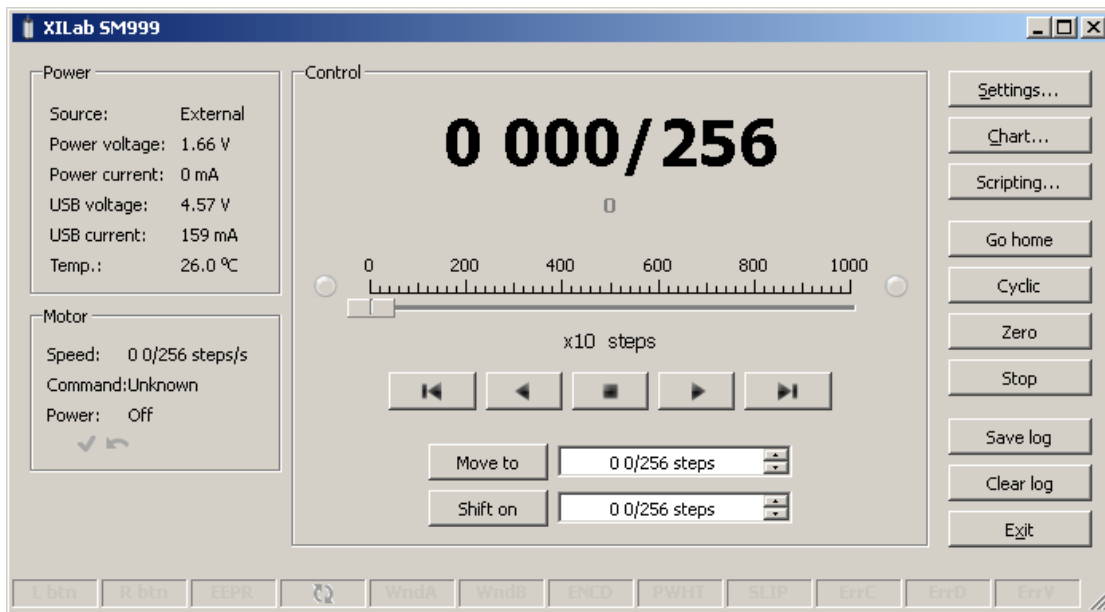

5.8.1.2. Installation on Windows 7

Copy the installer program file to your computer. The installer file name is "xilab-<version_name>.exe". It automatically detects whether it is running on 32-bit or 64-bit version of Windows and installs the appropriate version of XiLab.

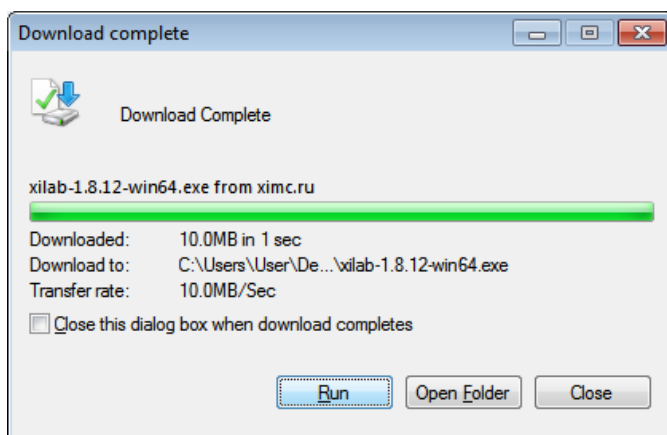
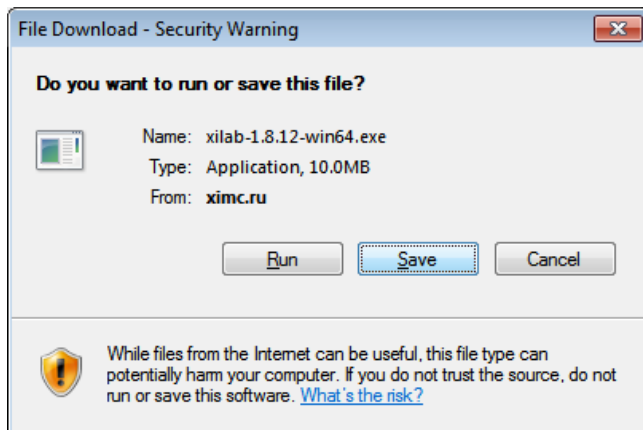

Run the installer and follow the on-screen instructions.

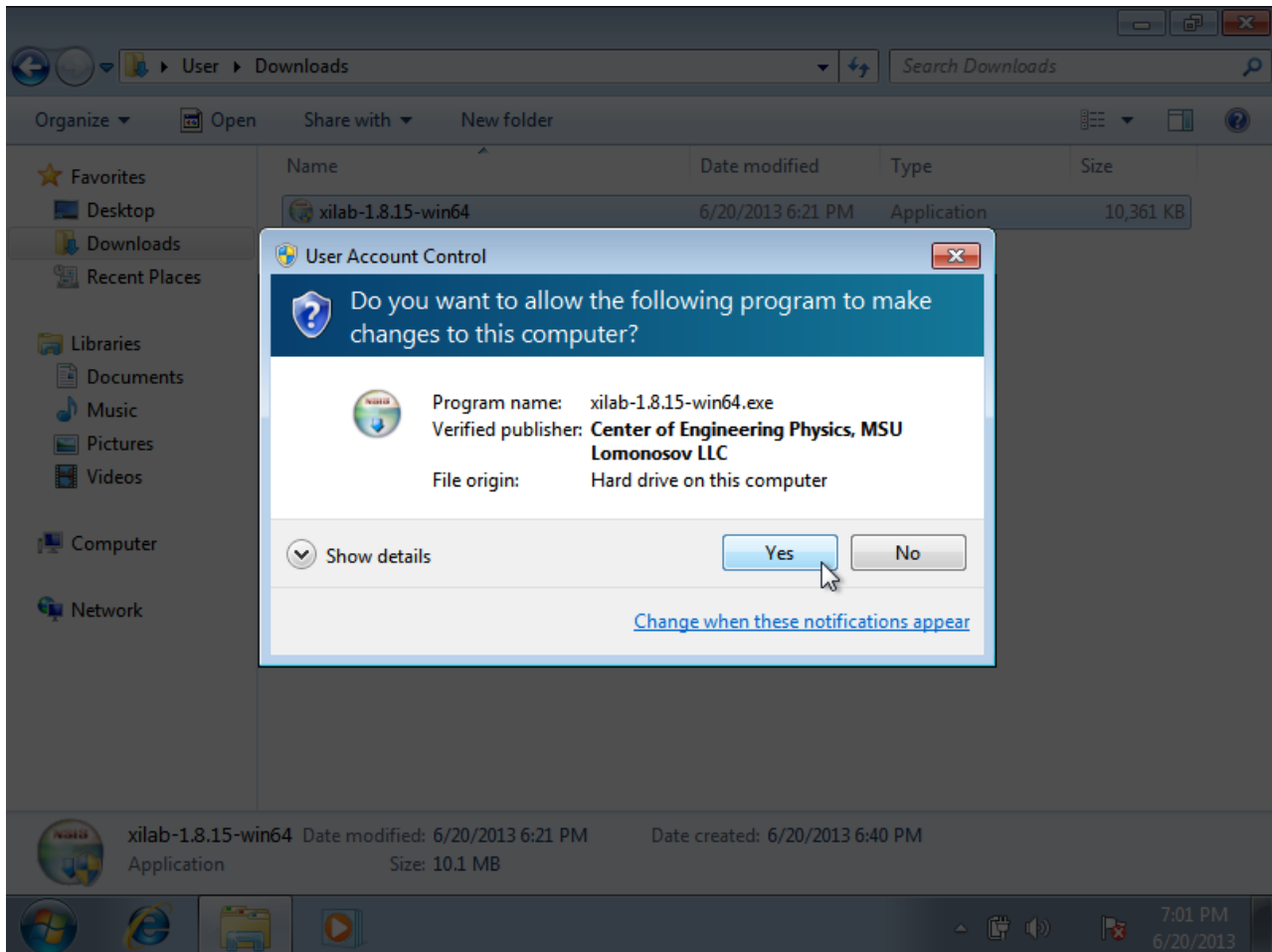
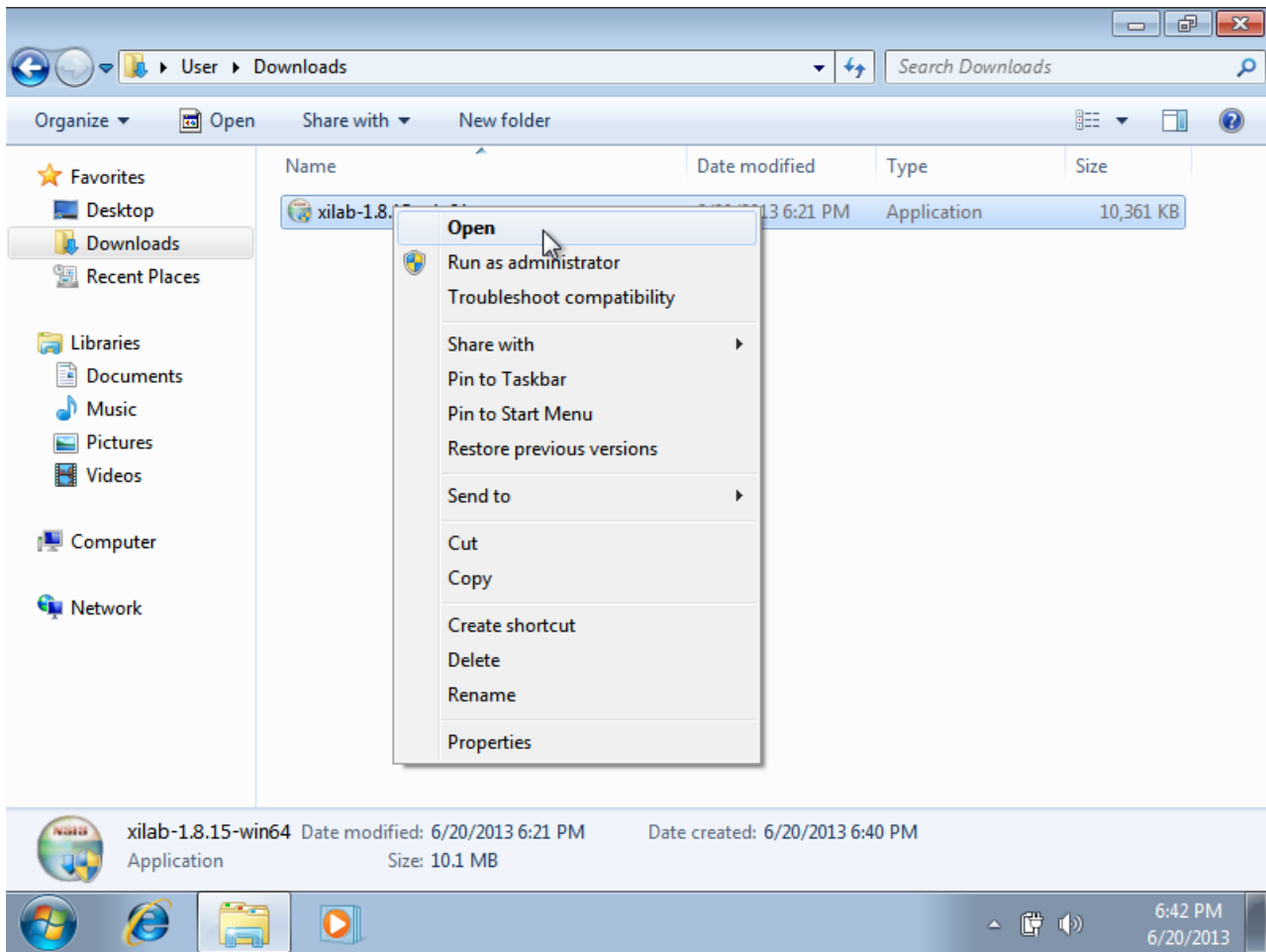

All the necessary software including drivers, packages and programs will be installed automatically.

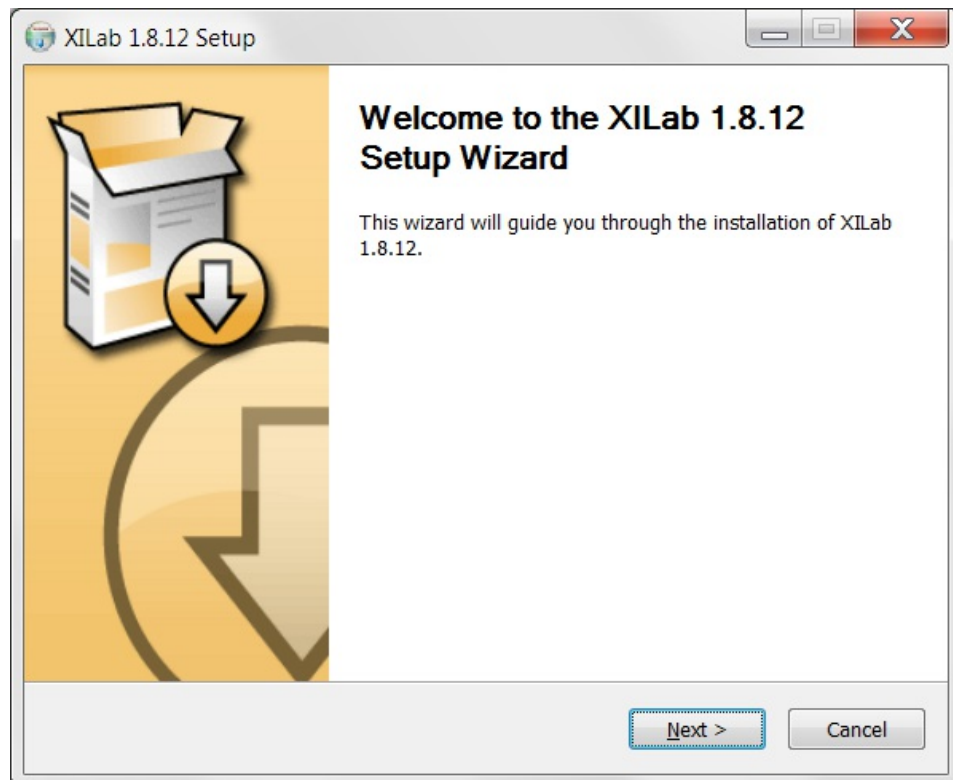

After the installation is complete the XiLab application will be started by default.



Connect the stage to the controller. Connect regulated power supply to the controller. Ground the controller or the power supply unit. Connect the controller to the computer using a USB-A - mini-USB-B cable.

LED indicator on the controller board will start to flash. New Hardware Wizard will start after the first controller is connected to the computer.

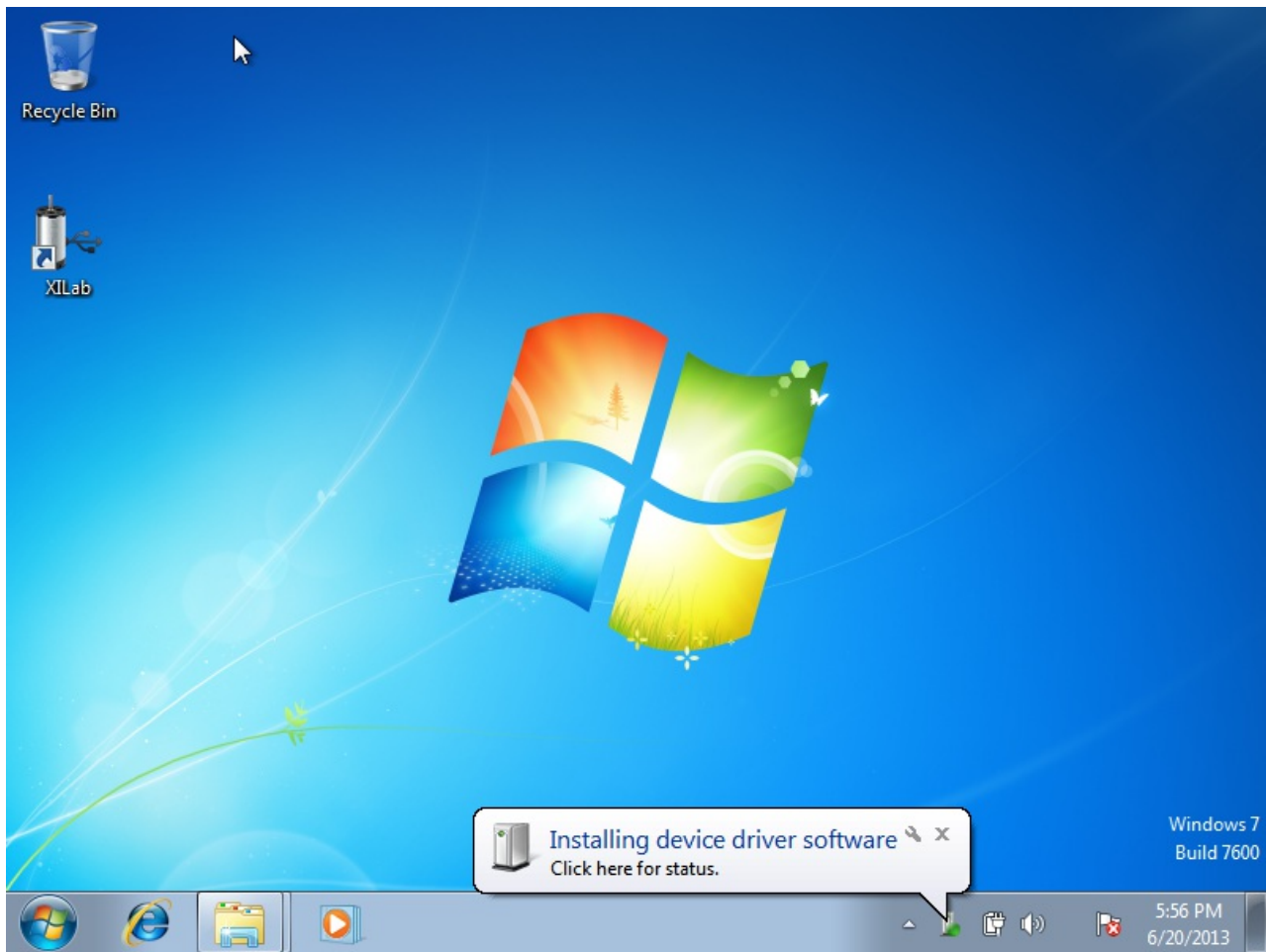

Wait until Windows detects the new device and installs the drivers for it. After the driver is successfully installed click Retry or run the Xilab application again if it was closed. The system will detect the connected controller and open the main Xilab window.



XILab SM1936614771

Power

Source: External
Power voltage: 1.37 V
Power current: 0 mA
USB voltage: 4.85 V
USB current: 144 mA
Temp.: 27.9 °C

Motor

Speed: 0 0/256 st
Command: Unknown
Power: Off

Control

0 000/256

0

0 200 400 600 800 1000

x10 steps

Move to 0 0/256 steps

Shift on 0 0/256 steps

Settings...
Chart...
Scripting...
Go home
Cyclic
Zero
Stop
Save log
Clear log
Exit

L btn | R btn | EEPR | ↻ | WndA | WndB | ENCD | PWHT | SLIP | ErrC | ErrD | ErrV | ?

5.8.1.3. Installation on Windows 8

Copy the installer program file to your computer. The installer file name is "xilab-<version_name>.exe". It automatically detects whether it is running on 32-bit or 64-bit version of Windows and installs the appropriate version of XILab. Run the installer and follow the on-screen instructions.

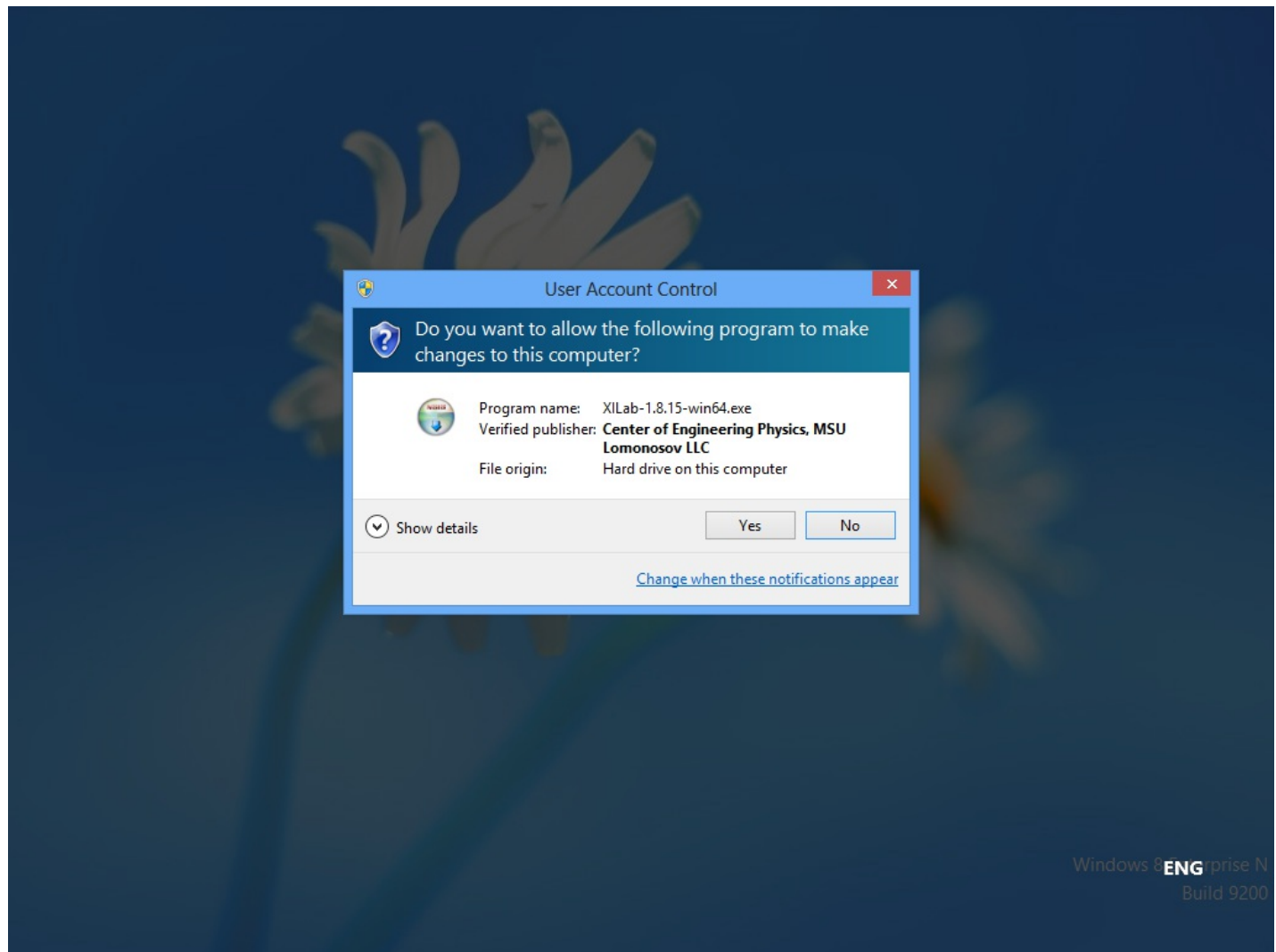

All the necessary software including drivers, packages and programs will be installed automatically.



After the installation is complete the XiLab application will be started by default.

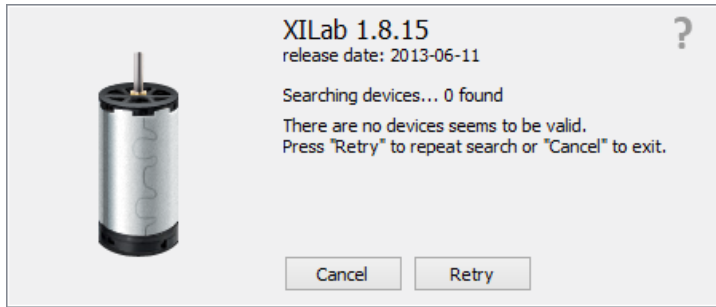

Connect the stage to the controller. Connect regulated power supply to the controller. Ground the controller or the power supply unit. Connect the controller to the computer using a USB-A - mini-USB-B cable.

LED indicator on the controller board will start to flash. New Hardware Wizard will start after the first controller is connected to the computer. Wait until Windows detects the new device and installs the drivers for it. After the driver is successfully installed, click Retry, or run the XiLab application again, if it was closed. The system will detect the connected controller and open the main XiLab window.

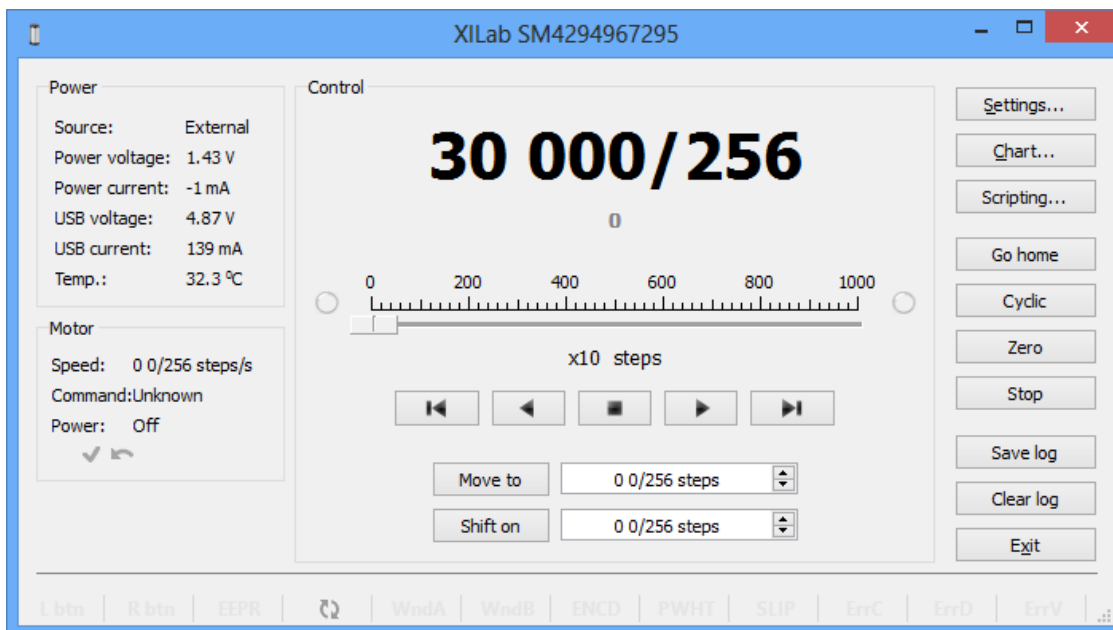
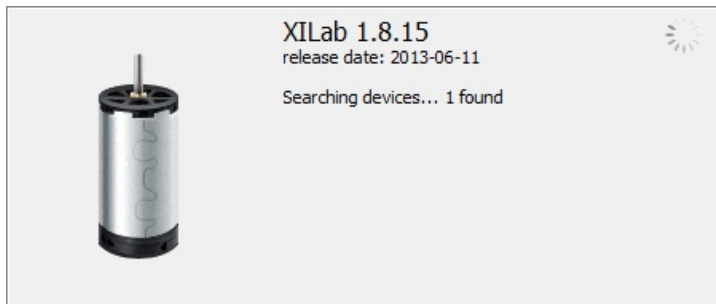

5.8.2. Installation on Linux

5.8.2. Installation on Linux
Debian / Ubuntu
Installing in graphical mode
The text installer
RedHat / OpenSUSE
The text installer

XILab package installs its files in the following directories:
/usr/bin/xilab - executable file
/usr/share/icons/xilab.png - Icon
/usr/share/xilab/scripts/ - directory scripts
/usr/share/xilab/profiles/ - directory with profiles
/usr/share/xilab/xilabdefault.cfg - file with the default settings

Debian / Ubuntu

Installing in graphical mode

Click on the file libximc6_x.y.z-1_i386.deb (for 32-bit versions of Linux) or libximc6_x.y.z-1_amd64.deb (for 64-bit versions of Linux). Installation window will appear. Click the Install package. This will install the libximc library.

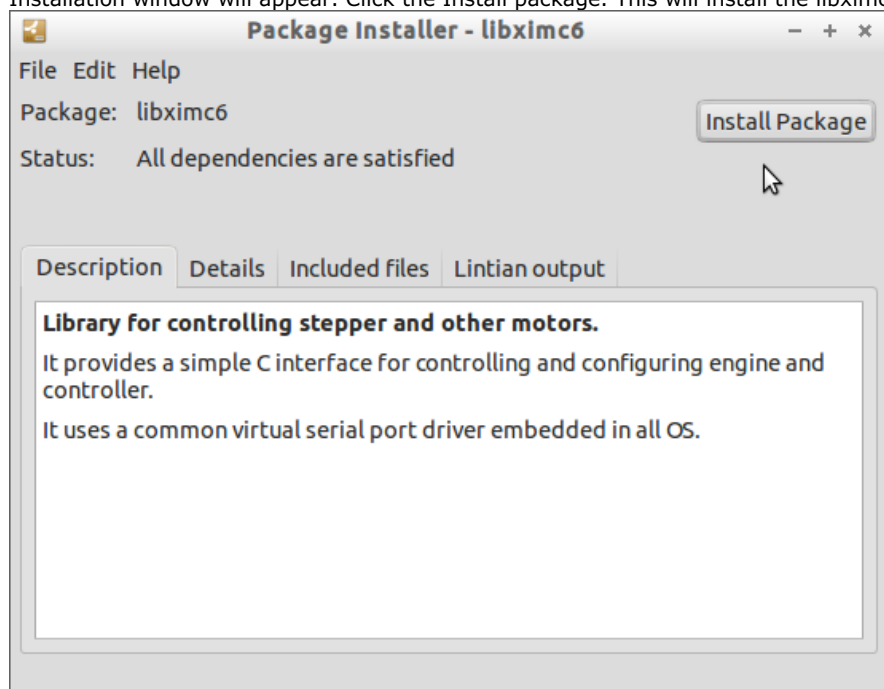

Click on the file `xilab_x.y.z-1_i386.deb` (for 32-bit versions of Linux) or `xilab_x.y.z-1_amd64.deb` (for 64-bit versions of Linux). Installation window will appear. Click the Install package. Dependencies and Xilab application will be installed.

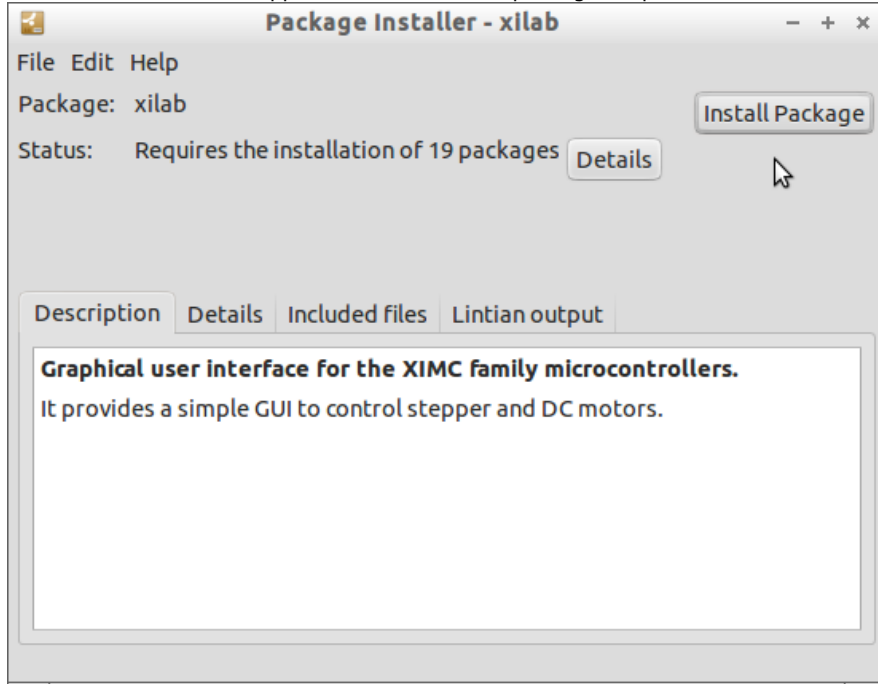

The text installer

Execute the following commands as super-user (root):

```
gdebi "<FILEPATH>/libximc6-<LIBVERSION>-1_<ARCH>.deb"
gdebi "<FILEPATH>/xilab-<VERSION>-1_<ARCH>.deb"
```

where `<FILEPATH>` is the path to package files (eg `"/home/user/Downloads/"`), `<LIBVERSION>` and `<VERSION>` are the version numbers of libximc library and xilab application respectively (for example, "2.0.2" and "1.8.12") and `<ARCH>` is the identifier of architecture ("i386" for 32-bit systems and "amd64" for 64-bit systems).

Example:

```
gdebi "/home/user/Downloads/libximc6-2.0.2-1_amd64.deb"
gdebi "/home/user/Downloads/xilab-1.8.12-1_amd64.deb"
```

Xilab application requires X-server (graphic mode) for operation.

RedHat / OpenSUSE

The text installer

Execute the following commands as super-user (root):

```
zypper install "<FILEPATH>/libximc6-<LIBVERSION>-1.<ARCH>.rpm"
zypper install "<FILEPATH>/xilab-<VERSION>-1.<ARCH>.rpm"
```

where `<FILEPATH>` is the path to package files (eg `"/home/user/Downloads/"`), `<LIBVERSION>` and `<VERSION>` are the version numbers of libximc library and Xilab application respectively (for example, "2.0.2" and "1.8.12") and `<ARCH>` is the identifier of architecture ("i386" for 32-bit systems and "amd64" for 64-bit systems).

Example:

```
zypper install "/home/user/Downloads/libximc6-2.0.2-1.x86_64.rpm"
zypper install "/home/user/Downloads/xilab-1.8.12-1.x86_64.rpm"
```

Xilab application requires X-server (graphic mode) for operation.

5.8.3. Installation on MacOS

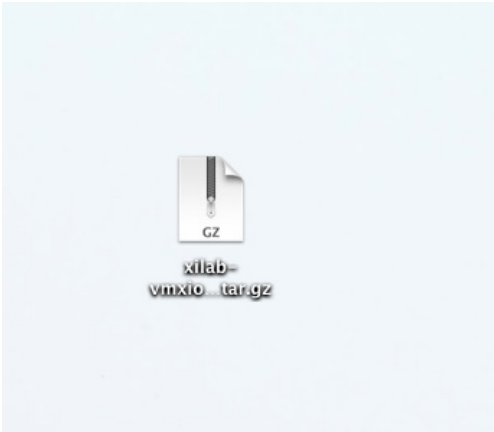

Copy the file with the installer archive to your computer. The archive with the installation program is named "xilab-<version_number>-osx64.tar.gz".

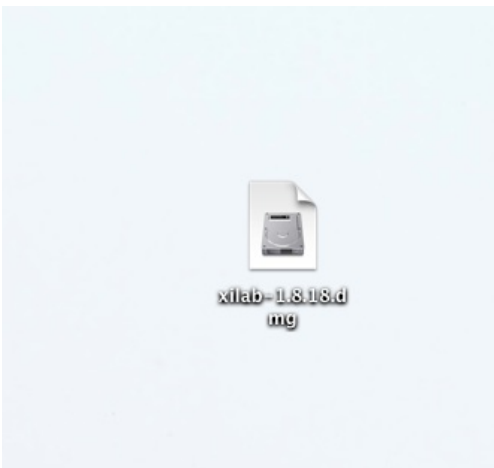

Unpack the archive by a mouse click.

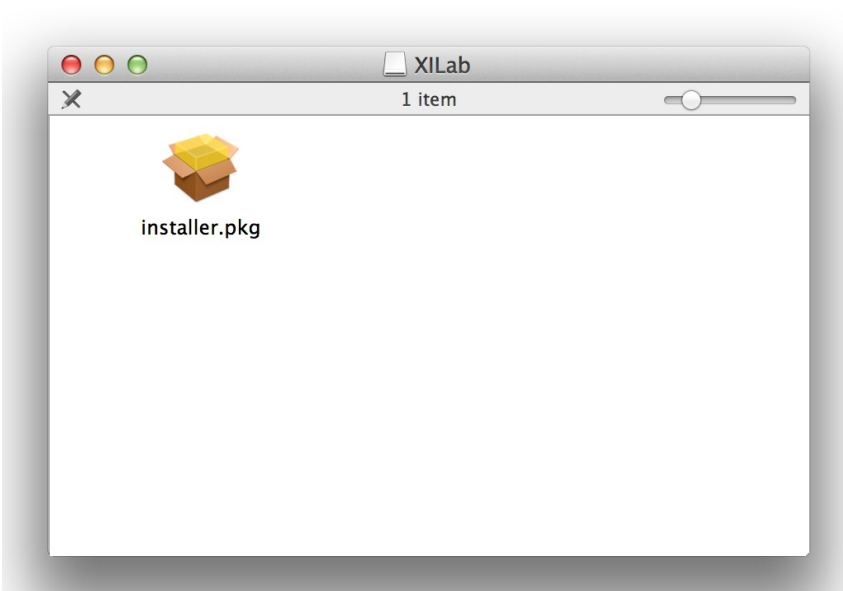

Make right button click on installer.pkg.

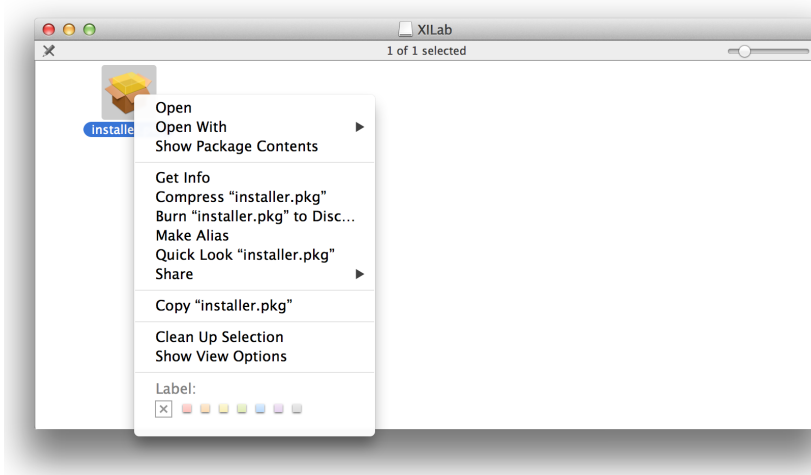

Choose "Open".

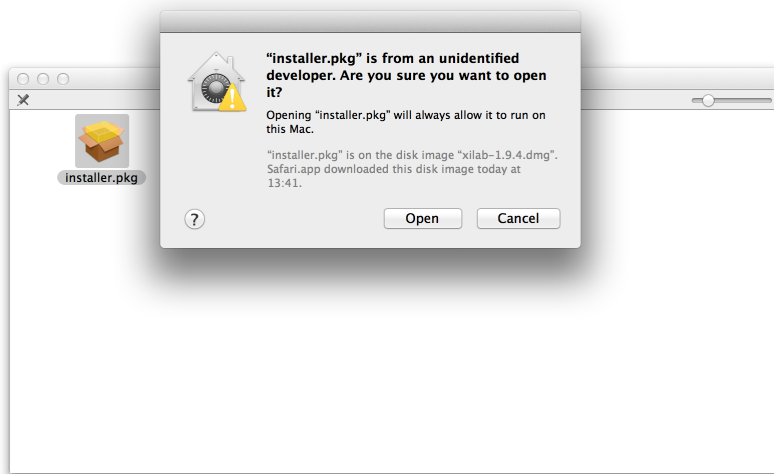

Choose "Open".

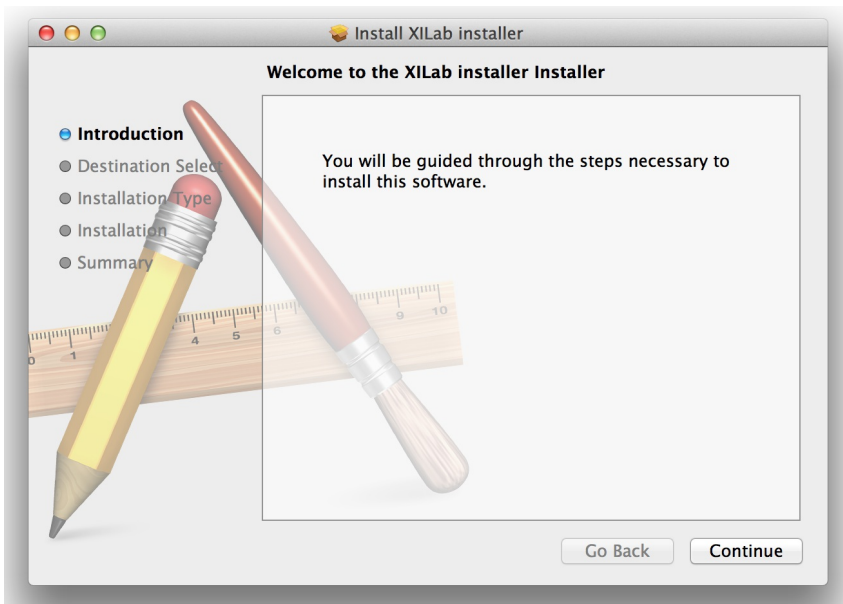

Select "Continue" in the main window of the installer.

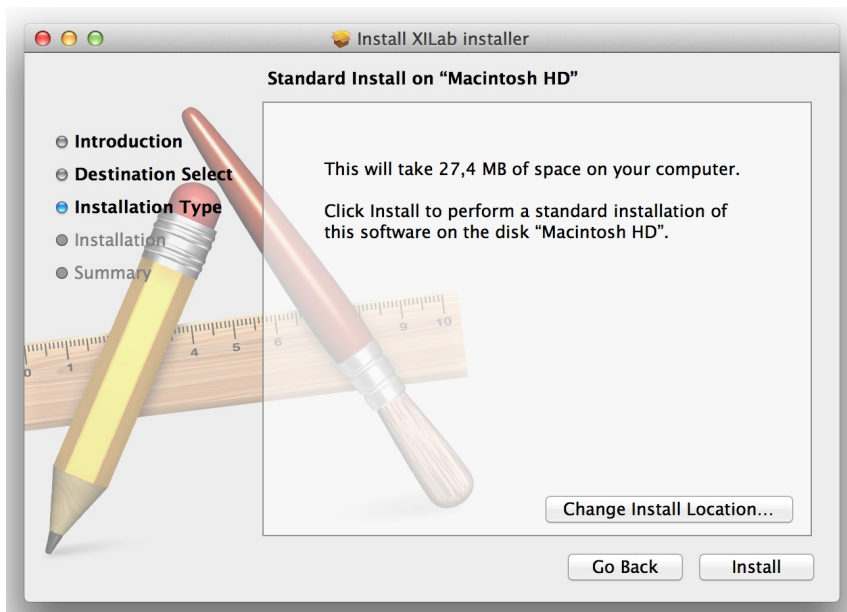

Now select "Install."



Enter the password.

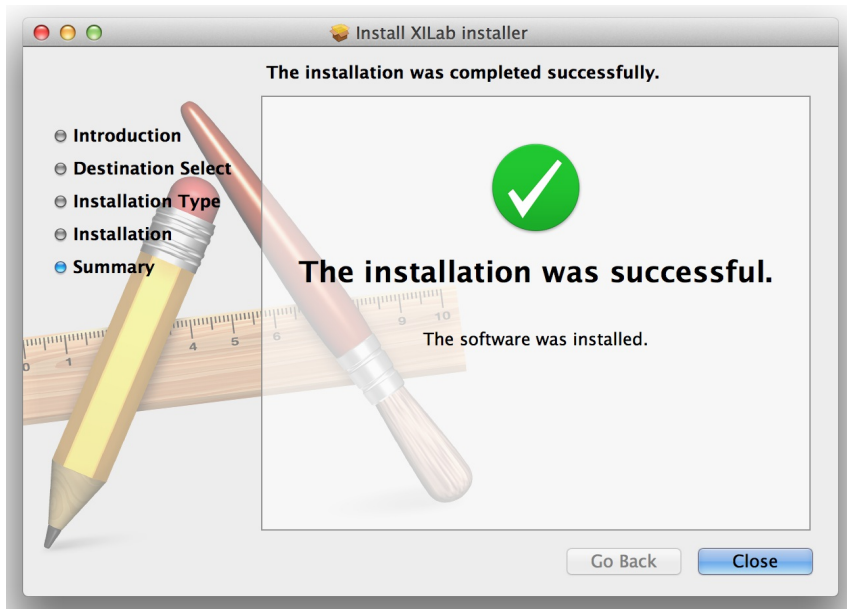

Wait until the installation is complete.

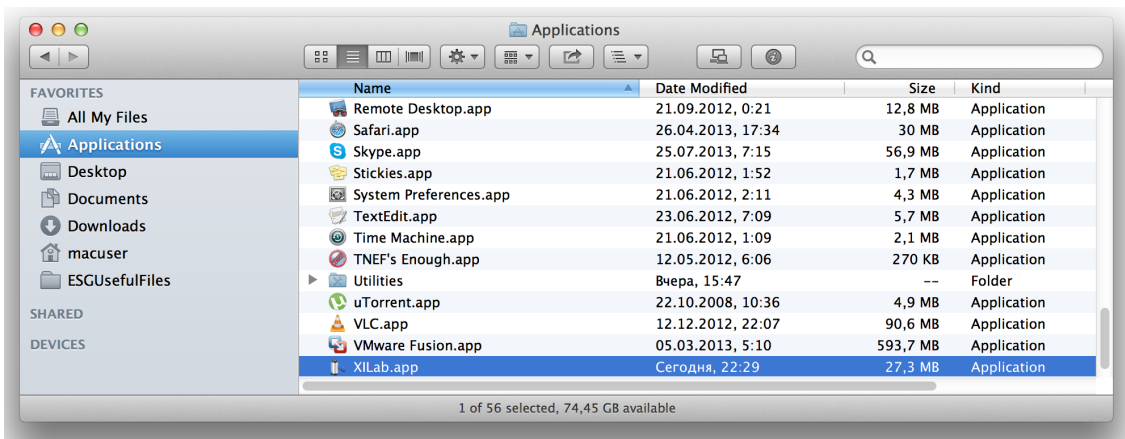

Select the XILab application in the Programs block

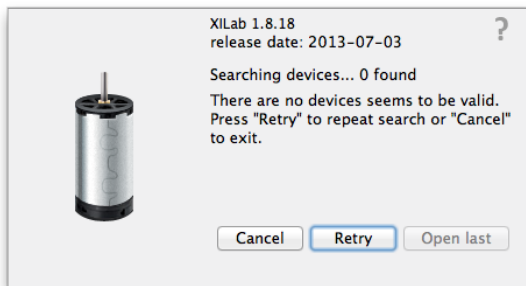

Start it.

6. Programming

1. [Programming guide](#)
 1. [Working with 8SMC5-USB in Labview](#)
 2. [Working with 8SMC5-USB in Labview](#)
2. [Communication protocol specification](#)
3. [8SMC1-USBhF software compatibility](#)
4. [Libximc library timeouts](#)
5. [XILab scripts](#)

6.1. Programming guide

Programming guide is included in development kit libximc 2.X.X, where 2.X.X is the version number. It is located in /ximc-2.X.X/ximc/doc-en/libximc7-en.pdf. Also the programming guide can be downloaded from [this link](#). Development kit can be downloaded on [Software](#) page. Programming guide is Doxygen-based.

[Working with 8SMC4-USB in Labview](#)

[Working with 8SMC4-USB in Matlab](#)

6.1.1. Working with controller in Labview

Download Labview example from the [Software](#) page.

Extract the archive and run "XImc Example One axis" file using Labview.

Name	Date modified	Type	Size
subvi	12/2/2014 4:43 PM	File folder	
VIs	12/2/2014 4:43 PM	File folder	
dir.mnu	3/25/2014 5:31 PM	MNU File	3 KB
libximc.dll	3/25/2014 5:25 PM	Application extension	61 KB
libximc	3/25/2014 5:31 PM	LVLIB File	12 KB
XImc Example One axis	7/10/2014 6:45 PM	LabVIEW Instrument	68 KB
XImc Example Three axes	3/25/2014 5:23 PM	LabVIEW Instrument	59 KB
XImc Labview Project	3/25/2014 5:11 PM	LabVIEW Project	5 KB

LabView environment will start. You will see graphical user interface of the front panel of the example, which looks like a simplified XILab interface.

In the left part of the window you can find a "Find controllers" button to rescan available controllers, a field to pick the controller by its serial port name and an information block which displays current open controller state (power and usb voltage and current, temperature and movement speed).

In the central part of the window you will find indication and control block. This block contains a numeric field with current position, left, right and soft stop buttons, controls to move to specified coordinate and shift on specified offset.

To the right of this block you can find "HOME", "ZERO", "STOP" and "Exit" buttons, which perform homing, zero current controller position, perform fast stop and exit the example, respectively.

The rightmost block is a "Move settings" dialog, which demonstrates how you can load and save settings to the controller. When you press its "GET" button current movement settings are loaded into the fields below this button and the "SET" button sends values from its edit fields to the controller.

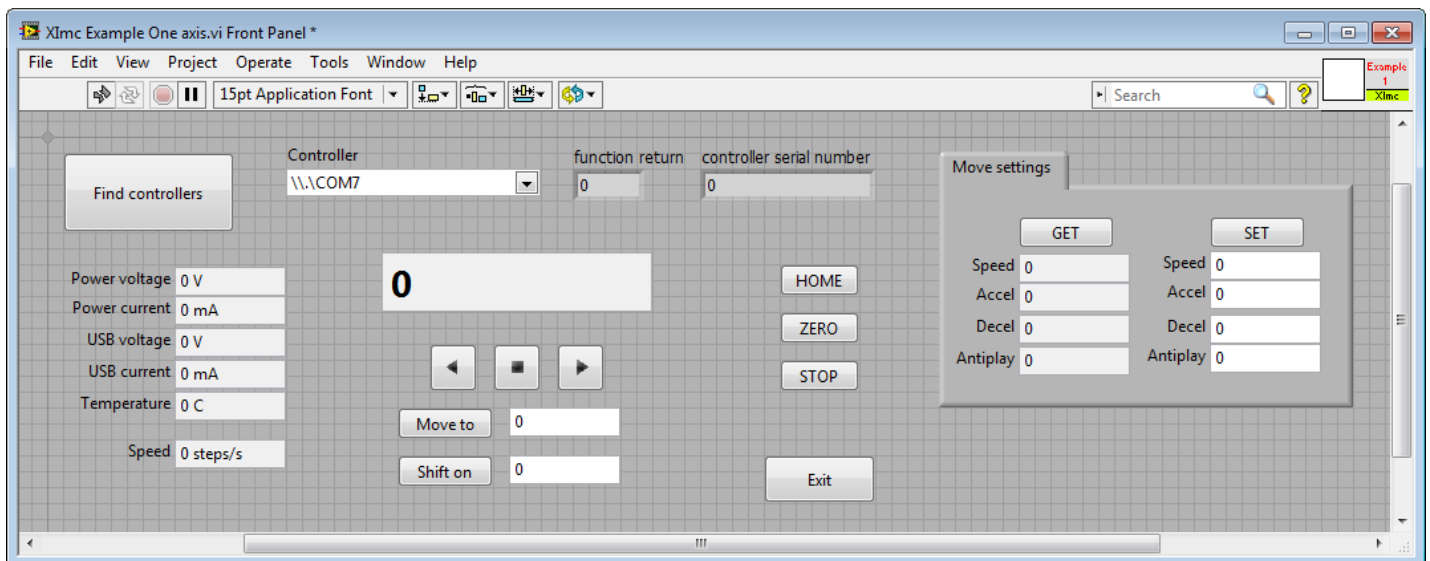

Example source can be viewed by entering edit mode. The example queries the controller status in an infinite loop and outputs the results. If you press any button on the front panel the corresponding functional block of the example is run.

Let's review how to create a simple Labview program with libximc library using "Ximc simple example.vi".

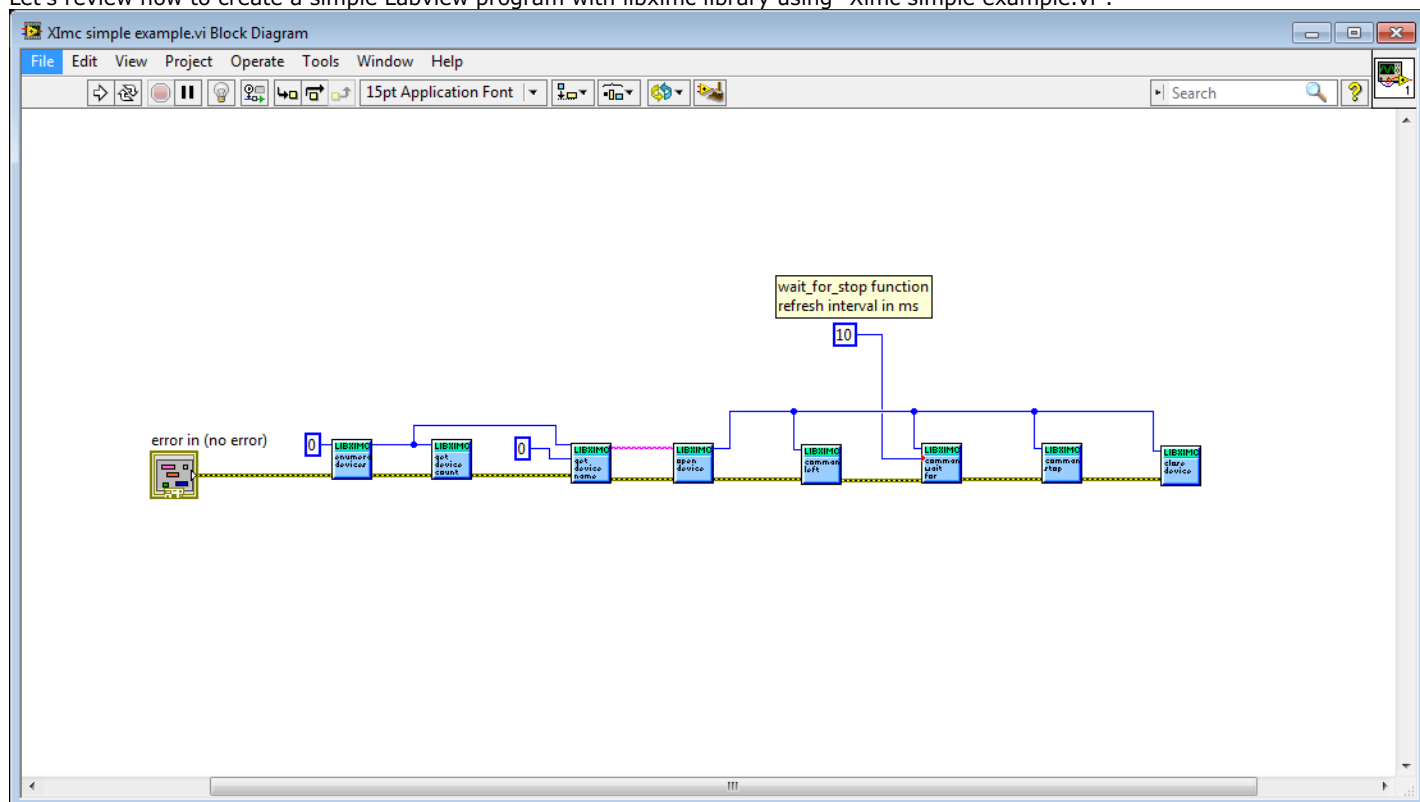

The program starts by calling `enumerate_devices` function and passing it the enumerate flags parameter (for details see [Programming guide](#)). Result of the `enumerate_devices` function call is an opaque pointer and is passed to the `get_device_name` function together with device number, whose name we want to find out (one can get total number of found devices by passing the same opaque pointer to the `get_device_count` function). Result of the `get_device_name` function call is a string, which is passed to the `open_device` function. This function call sequence is not mandatory (though recommended) - one can manually form device name string and pass it to the `open_device` function directly.

Result of the `open_device` function call is a device handle, or a `ximc.h` header constant `device_undefined`, which is returned if `libximc` could not open specified device. Device handle is passed to all functions which read data from the controller, write data to the controller or send commands to the controller, together with appropriate parameters if necessary by function prototype. "Ximc simple example.vi" calls `command_left`, `command_wait_for_stop` and `command_stop` as an example. After you stop using the controller you need to close its handle by passing it to the `close_device` function. After you stop using `enumerate_devices` result you need to free allocated memory pointed to by this opaque pointer by passing it to the `free_enumerate_devices` function (not shown in this example).

Note. `libximc` library opens controllers in exclusive access mode. Any controller opened by `libximc` needs to be closed before it may be used by another process. Do not stop this Labview example or any other Labview program which uses `libximc` with the "Abort execution" button - this doesn't give the running program a chance to call the `close_device()` function, thus all open controllers will become locked and inaccessible until you close Labview environment entirely.

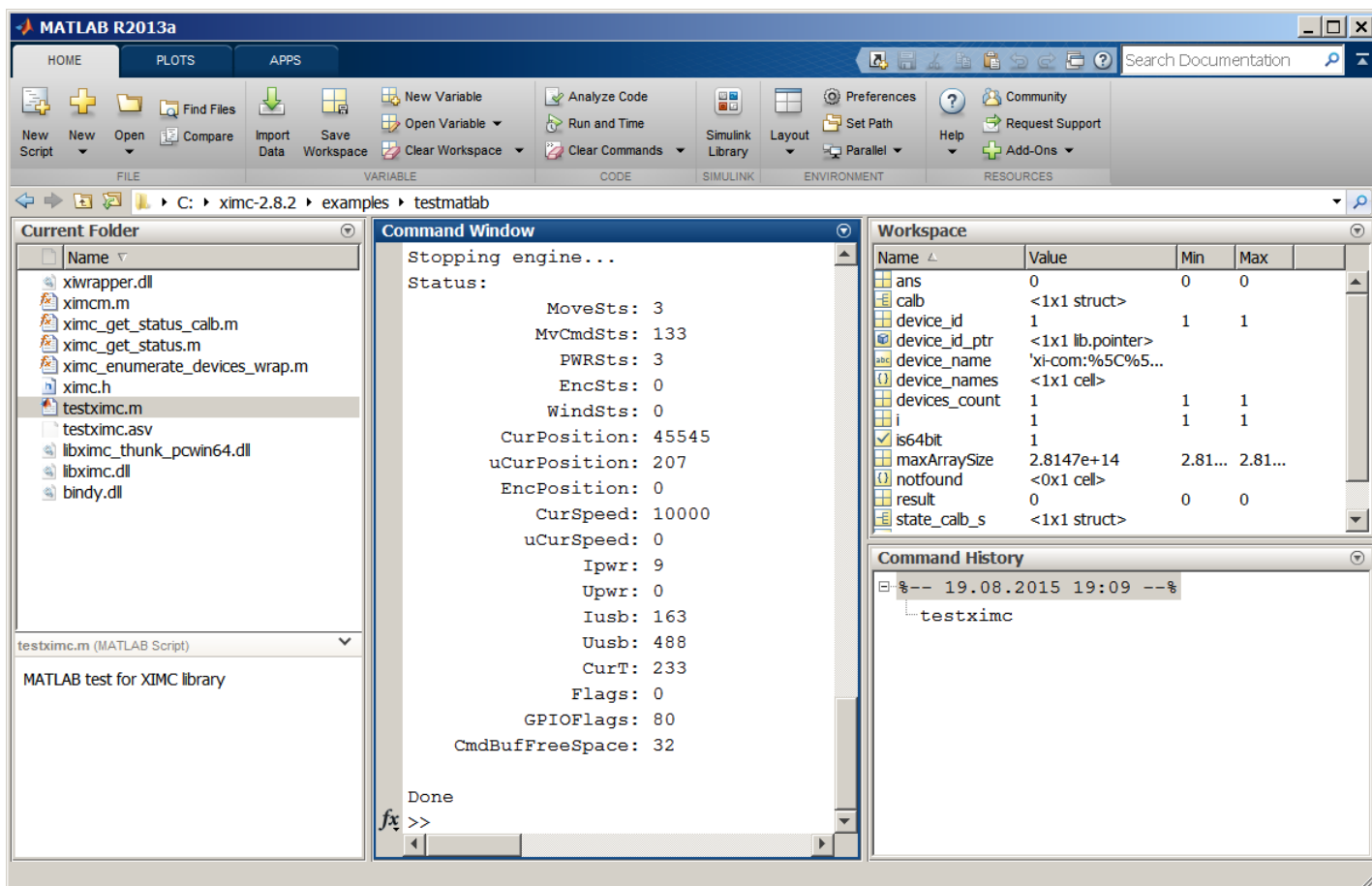

In the command window you will see the output of the example which reports controller status.

You can call `libximc` functions from Matlab program this way: define the path to the `libximc.dll`, `bindy.dll` and `xiwrapper.dll` dynamic link libraries and its header `ximc.h` and additional to `libximc_thunk_pwin64.dll` and `ximc.m` files if you are using 64-bin environment. Use `loadlibrary` Matlab function once to load `libximc` library, then use `calllib` Matlab function to call desired `libximc` function. You will find a list of `libximc` functions and their input and output parameters in the [Programming guide](#).

6.2. Communication protocol specification (v17.5)

6.2. Communication protocol specification (v17.5)

Protocol description

Command execution

Controller-side error processing

Wrong command or data

CRC calculation

Transmission errors

Timeout resynchronization

Zero byte resynchronization

Library-side error processing

Library return codes

Zero byte synchronization procedure

Controller settings setup

Command SFBS

Command GFBS

Command SHOM

Command GHOM

Command SMOV

Command GMOV

Command SENG

Command GENG

Command SENT

Command GENT

Command SPWR

Command GPWR

Command SSEC

Command GSEC

Command SEDS

Command GEDS

Command SPID

Command GPID

Command SSNI

Command GSNI

Command SSNO

Command GSNO

Command SEIO

Command GEIO

Command SBRK

Command GBRK

Command SCTL

Command GCTL

Command SJOY

Command GJOY

Command SCTP

Command GCTP

Command SURT

Command GURT

Command SCAL

Command GCAL

Command SNMF

Command GNMF

Command SNVM

Command GNVM

Group of commands movement control

Command STOP

Command ASIA

Command PWOFF

Command MOVE

Command MOVR

Command HOME

Command LEFT

Command RIGT

Command LOFT

Command SSTP

Group of commands set the current position

Command GPOS

Command SPOS

Command ZERO

Group of commands to save and load settings
Command SAVE
Command READ
Command SARS
Command RERS
Command EESV
Command EERD

Group of commands get the status of the controller
Command GETS
Command STMS
Command GETM
Command GETC
Command GETI
Command GSER

Group of commands to work with the controller firmware
Command GFVV
Command UPDF

Service commands
Command SSER
Command RDAN
Command DBGR
Command DBGW

Group of commands to work with EEPROM
Command SNME
Command GNME
Command SSTI
Command GSTI
Command SSTS
Command GSTS
Command SMTI
Command GMTI
Command SMTS
Command GMTS
Command SENI
Command GENI
Command SENS
Command GENS
Command SHSI
Command GHSI
Command SHSS
Command GHSS
Command SGRI
Command GGRI
Command SGRS
Command GGRS
Command SACC
Command GACC

Bootloader commands
Command GBLV
Command IRND
Command GUID
Command CHMT

Controller error response types
ERRC
ERRD
ERRV

Protocol description

Controller can be controlled from the PC using serial connection (COM-port). COM-port parameters are fixed controller-side:

Speed: 115200 baud;
Frame size: 8 bits;
Stop-bits: 2 bits;
Parity: none;
Flow control: none;
Byte receive timeout: 400 ms;
Bit order: little endian;
Byte order: little endian.

Command execution

All data transfers are initiated by the PC, meaning that the controller waits for incoming commands and replies accordingly. Each command is followed by the controller response, with rare exceptions of some service commands. One should not send another command without waiting for the previous command answer.

Commands are split into service, general control and general information types.

Commands are executed immediately. Parameters which are set by Sxxx commands are applied no later than 1ms after acknowledgement.

Command processing does not affect real-time engine control (PWM, encoder readout, etc).

Both controller and PC have an IO buffer. Received commands and command data are processed once and then removed from buffer.

Each command consists of 4-byte identifier and optionally a data section followed by its 2-byte CRC. Data can be transmitted in both directions, from PC to the controller and vice versa. Command is scheduled for execution if it is a legitimate command and (in case of data) if its CRC matches. After processing a correct command controller replies with 4 bytes - the name of processed command, followed by data and its 2-byte CRC, if the command is supposed to return data.

Controller-side error processing

Wrong command or data

If the controller receives a command that cannot be interpreted as a legitimate command, then controller ignores this command, replies with an "errc" string and sets "command error" flag in the current status data structure. If the unrecognized command contained additional data, then it can be interpreted as new command(s). In this case resynchronization is required.

If the controller receives a valid command with data and its CRC doesn't match the CRC computed by the controller, then controller ignores this command, replies with an "errd" string and sets "data error" flag in the current status data structure. In this case synchronization is not needed.

CRC calculation

CRC is calculated for data only, 4-byte command identifier is not included. CRC algorithm in C is as follows:

```
unsigned short CRC16(INT8U *pbuf, unsigned short n)
{
    unsigned short crc, i, j, carry_flag, a;
    crc = 0xffff;
    for(i = 0; i < n; i++)
    {
        crc = crc ^ pbuf[i];
        for(j = 0; j < 8; j++)
        {
            a = crc;
            carry_flag = a & 0x0001;
            crc = crc >> 1;
            if ( carry_flag == 1 ) crc = crc ^ 0xa001;
        }
    }
    return crc;
}
```

This function receives a pointer to the data array, pbuf, and data length in bytes, n. It returns a two byte CRC code.

Transmission errors

Most probable transmission errors are missing, extra or altered byte. In usual settings transmission errors happen rarely, if at all. Frequent errors are possible when using low-quality or broken USB-cable or board interconnection cable. Protocol is not designed for use in noisy environments and in rare cases an error may match a valid command code and get executed.

Missing byte, controller side

A missing byte on the controller side leads to a timeout on the PC side. Command is considered to be sent unsuccessfully by the PC. Synchronization is momentarily disrupted and restored after a timeout.

Missing byte, PC side

A missing byte on the PC side leads to a timeout on PC side. Synchronization is maintained.

Extra byte, controller side

An extra byte received by the controller leads to one or several "errc" or "errd" responses. Command is considered to be sent unsuccessfully by the PC. Receive buffer may also contain one or several "errc" or "errd" responses. Synchronization is disrupted.

Extra byte, PC side

An extra byte received by the PC leads to an incorrectly interpreted command or CRC and an extra byte in the receive buffer. Synchronization is disrupted.

Altered byte, controller side

An altered byte received by the controller leads to one or several "errc" or "errd" responses. Command is considered to be sent unsuccessfully by the PC. Receive buffer may also contain one or several "errc" or "errd" responses. Synchronization can rarely be disrupted, but is generally maintained.

Altered byte, PC side

An altered byte received by the PC leads to an incorrectly interpreted command or CRC. Synchronization is maintained.

Timeout resynchronization

If during packet reception next byte wait time exceeds timeout value, then partially received command is ignored and receive buffer is cleared. Controller timeout should be less than PC timeout, taking into account time it takes to transmit the data.

Zero byte resynchronization

There are no command codes that start with a zero byte ('\0'). This allows for a following synchronization procedure: controller always answers with a zero byte if the first command byte is zero, PC ignores first response byte if it is a zero byte. Then, if synchronization is disrupted on either side the following algorithm is used:

In case PC receives "errc", "errd" or a wrong command answer code, then PC sends 4 to 250 zeroes to the controller (250 byte limit is caused by input buffer length and usage of I2C protocol, less than 4 zeroes do not guarantee successful resynchronization). During this time PC continuously reads incoming bytes from the controller until the first zero is received and stops sending and receiving right after that.

Received zero byte is likely not a part of a response to a previous command because on error PC receives "errc"/"errd" response. It is possible in rare cases, then synchronization procedure will start again. Therefore first zero byte received by the PC means that controller input buffer is already empty and will remain so until any command is sent. Right after receiving first zero byte from the controller PC is ready to transmit next command code. The rest of zero bytes in transit will be ignored because they will be received before controller response.

This completes the zero byte synchronization procedure.

Library-side error processing

Nearly every library function has a return status of type `result_t`.

After sending command to the controller library reads incoming bytes until a non-zero byte is received. All zero bytes are ignored. Library reads first 4 bytes and compares them to the command code. It then waits for data section and CRC, if needed. If first 4 received bytes do not match the sent command identifier, then zero byte synchronization procedure is launched, command is considered to be sent unsuccessfully. If first 4 received bytes match the sent command identifier and command has data section, but the received CRC doesn't match CRC calculated from the received data, then zero byte synchronization procedure is launched, command is considered to be sent unsuccessfully. If a timeout is reached while the library is waiting for the controller response, then zero byte synchronization procedure is launched, command is considered to be sent unsuccessfully.

If no errors were detected, then command is considered to be successfully completed and `result_ok` is returned.

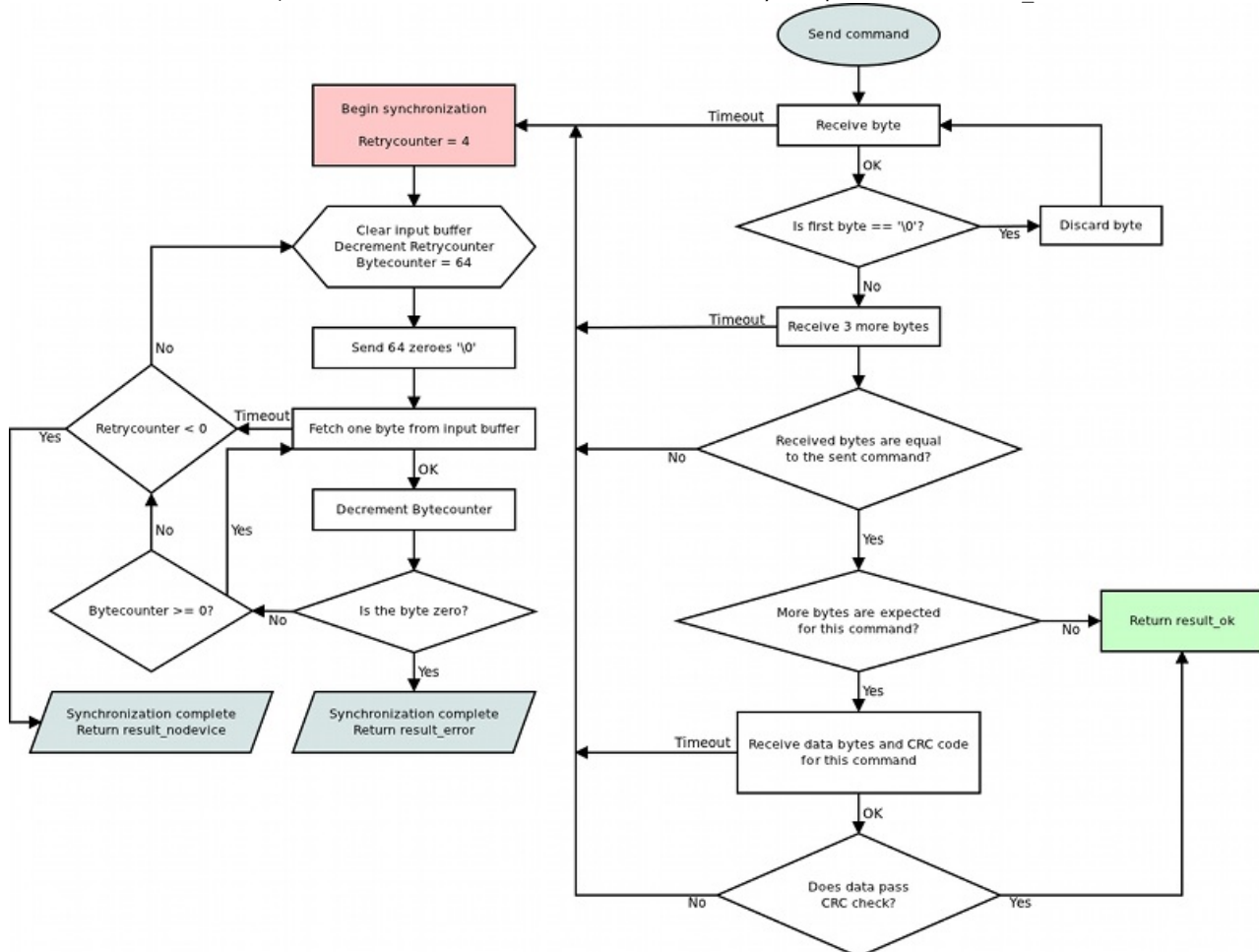

Library return codes

- `result_ok`. No errors detected.
- `result_error`. Generic error. Can happen because of hardware problems, empty port buffer, timeout or successful synchronization after an error. Another common reason for this error is protocol version mismatch between controller firmware

and PC library.

- `result_noddevice`. Error opening device, lost connection or failed synchronization. Device reopen and/or user action is required.

If a function returns an error values of all parameters it writes to are undefined. Error code may be accompanied by detailed error description output to system log (Unix-like OS) or standard error (Windows-like OS).

Zero byte synchronization procedure

Synchronization is performed by means of sending zero ('\0') bytes and reading bytes until a zero byte is received. Optionally one may clear port buffer at the end of synchronization procedure. Initially 64 zero bytes are sent. If there were no zero bytes received during the timeout, then a string of 64 bytes is sent 3 more times. After 4 unsuccessful attempts and no zero bytes received device is considered lost. In this case library should return `result_noddevice` error code. In case of successful synchronization library returns `result_error`.

Controller settings setup

Functions for adjusting engine read/write almost all controller settings.

Command SFBS

```
result_t set_feedback_settings (device_t id, const feedback_settings_t* feedback_settings)
```

Command code (CMD): "sfbs" or 0x73626673.

Request: (18 bytes)

INT32U	CMD	Command
INT16U	IPS	The number of encoder counts per shaft revolution. Range: 1..65535. The field is obsolete, it is recommended to write 0 to IPS and use the extended CountsPerTurn field. You may need to update the controller firmware to the latest version.
INT8U	FeedbackType	Type of feedback
		0x01 - FEEDBACK_ENCODER (Feedback by encoder.)
		0x03 - FEEDBACK_ENCODERHALL (Feedback by Hall detector.)
		0x04 - FEEDBACK_EMF (Feedback by EMF.)
		0x05 - FEEDBACK_NONE (Feedback is absent.)
INT8U	FeedbackFlags	Flags
		0x01 - FEEDBACK_ENC_REVERSE (Reverse count of encoder.)
		0x02 - FEEDBACK_HALL_REVERSE (Reverse count position on the Hall sensor.)
		0xC0 - FEEDBACK_ENC_TYPE_BITS (Bits of the encoder type.)
		0x00 - FEEDBACK_ENC_TYPE_AUTO (Auto detect encoder type.)
		0x40 - FEEDBACK_ENC_TYPE_SINGLE_ENDED (Single ended encoder.)
		0x80 - FEEDBACK_ENC_TYPE_DIFFERENTIAL (Differential encoder.)
INT16U	HallSPR	The number of hall steps per revolution.
INT8S	HallShift	Phase shift between output signal on BLDC engine and hall sensor input(0 - when only active the Hall sensor, the output state is a positive voltage on the winding A and a negative voltage on the winding B).
INT8U	Reserved [5]	Reserved (5 bytes)
INT16U	CRC	Checksum

Answer: (4 bytes)

INT32U	CMD	Command (answer)
--------	-----	------------------

Description:

Feedback settings.

Command GFBS

```
result_t get_feedback_settings (device_t id, feedback_settings_t* feedback_settings)
```

Command code (CMD): "gfbs" or 0x73626667.

Request: (4 bytes)

INT32U	CMD	Command
--------	-----	---------

Answer: (18 bytes)

INT32U	CMD	Command (answer)
INT16U	IPS	The number of encoder counts per shaft revolution. Range: 1..65535. The field is obsolete, it is recommended to write 0 to IPS and use the extended CountsPerTurn field. You may need to update the controller firmware to the latest version.
INT8U	FeedbackType	Type of feedback
		0x01 - FEEDBACK_ENCODER (Feedback by encoder.)
		0x03 - FEEDBACK_ENCODERHALL (Feedback by Hall detector.)
		0x04 - FEEDBACK_EMF (Feedback by EMF.)
		0x05 - FEEDBACK_NONE (Feedback is absent.)
INT8U	FeedbackFlags	Flags
		0x01 - FEEDBACK_ENC_REVERSE (Reverse count of encoder.)
		0x02 - FEEDBACK_HALL_REVERSE (Reverse count position on the Hall sensor.)
		0xC0 - FEEDBACK_ENC_TYPE_BITS (Bits of the encoder type.)
		0x00 - FEEDBACK_ENC_TYPE_AUTO (Auto detect encoder type.)
		0x40 - FEEDBACK_ENC_TYPE_SINGLE_ENDED (Single ended encoder.)
		0x80 - FEEDBACK_ENC_TYPE_DIFFERENTIAL (Differential encoder.)
INT16U	HallSPR	The number of hall steps per revolution.
INT8S	HallShift	Phase shift between output signal on BLDC engine and hall sensor input(0 - when only active the Hall sensor, the output state is a positive voltage on the winding A and a negative voltage on the winding B).
INT8U	Reserved [5]	Reserved (5 bytes)
INT16U	CRC	Checksum

Description:

Feedback settings.

Command SHOM

```
result_t set_home_settings (device_t id, const home_settings_t* home_settings)
```

Command code (CMD): "shom" or 0x6D6F6873.

Request: (33 bytes)

INT32U	CMD	Command
INT32U	FastHome	Speed used for first motion. Range: 0..100000.
INT8U	uFastHome	Part of the speed for first motion, microsteps.
INT32U	SlowHome	Speed used for second motion. Range: 0..100000.
INT8U	uSlowHome	Part of the speed for second motion, microsteps.
INT32S	HomeDelta	Distance from break point.
INT16S	uHomeDelta	Part of the delta distance, microsteps. Range: -255..255.
INT16U	HomeFlags	Set of flags specify direction and stopping conditions.
		0x001 - HOME_DIR_FIRST (Flag defines direction of 1st motion after execution of home command. Direction is right, if set; otherwise left.)
		0x002 - HOME_DIR_SECOND (Flag defines direction of 2nd motion. Direction is right, if set; otherwise left.)
		0x004 - HOME_MV_SEC_EN (Use the second phase of calibration to the home position, if set; otherwise the second phase is skipped.)
		0x008 - HOME_HALF_MV (If the flag is set, the stop signals are ignored in start of second movement the first half-turn.)
		0x030 - HOME_STOP_FIRST_BITS (Bits of the first stop selector.)
		0x010 - HOME_STOP_FIRST_REV (First motion stops by revolution sensor.)
		0x020 - HOME_STOP_FIRST_SYN (First motion stops by synchronization input.)
		0x030 - HOME_STOP_FIRST_LIM (First motion stops by limit switch.)
		0x0C0 - HOME_STOP_SECOND_BITS (Bits of the second stop selector.)
		0x040 - HOME_STOP_SECOND_REV (Second motion stops by revolution sensor.)
		0x080 - HOME_STOP_SECOND_SYN (Second motion stops by synchronization input.)
		0x0C0 - HOME_STOP_SECOND_LIM (Second motion stops by limit switch.)
		0x100 - HOME_USE_FAST (Use the fast algorithm of calibration to the home position, if set; otherwise the traditional algorithm.)
INT8U	Reserved [9]	Reserved (9 bytes)
INT16U	CRC	Checksum

Answer: (4 bytes)

INT32U	CMD	Command (answer)
--------	-----	------------------

Description:

Set home settings. This function send structure with calibrating position settings to controller's memory.

Command GHOM

```
result_t get_home_settings (device_t id, home_settings_t* home_settings)
```

Command code (CMD): "ghom" or 0x6D6F6867.

Request: (4 bytes)

INT32U	CMD	Command
--------	-----	---------

Answer: (33 bytes)

INT32U	CMD	Command (answer)
INT32U	FastHome	Speed used for first motion. Range: 0..100000.
INT8U	uFastHome	Part of the speed for first motion, microsteps.
INT32U	SlowHome	Speed used for second motion. Range: 0..100000.
INT8U	uSlowHome	Part of the speed for second motion, microsteps.
INT32S	HomeDelta	Distance from break point.
INT16S	uHomeDelta	Part of the delta distance, microsteps. Range: -255..255.
INT16U	HomeFlags	Set of flags specify direction and stopping conditions.
		0x001 - HOME_DIR_FIRST (Flag defines direction of 1st motion after execution of home command. Direction is right, if set; otherwise left.)
		0x002 - HOME_DIR_SECOND (Flag defines direction of 2nd motion. Direction is right, if set; otherwise left.)
		0x004 - HOME_MV_SEC_EN (Use the second phase of calibration to the home position, if set; otherwise the second phase is skipped.)
		0x008 - HOME_HALF_MV (If the flag is set, the stop signals are ignored in start of second movement the first half-turn.)
		0x030 - HOME_STOP_FIRST_BITS (Bits of the first stop selector.)
		0x010 - HOME_STOP_FIRST_REV (First motion stops by revolution sensor.)
		0x020 - HOME_STOP_FIRST_SYN (First motion stops by synchronization input.)
		0x030 - HOME_STOP_FIRST_LIM (First motion stops by limit switch.)
		0x0C0 - HOME_STOP_SECOND_BITS (Bits of the second stop selector.)
		0x040 - HOME_STOP_SECOND_REV (Second motion stops by revolution sensor.)
		0x080 - HOME_STOP_SECOND_SYN (Second motion stops by synchronization input.)
		0x0C0 - HOME_STOP_SECOND_LIM (Second motion stops by limit switch.)
		0x100 - HOME_USE_FAST (Use the fast algorithm of calibration to the home position, if set; otherwise the traditional algorithm.)
INT8U	Reserved [9]	Reserved (9 bytes)
INT16U	CRC	Checksum

Description:

Read home settings. This function fill structure with settings of calibrating position.

Command SMOV

```
result_t set_move_settings (device_t id, const move_settings_t* move_settings)
```

Command code (CMD): "smov" or 0x766F6D73.

Request: (30 bytes)

INT32U	CMD	Command
INT32U	Speed	Target speed (for stepper motor: steps/s, for DC: rpm). Range: 0..100000.
INT8U	uSpeed	Target speed in microstep fractions/s. Using with stepper motor only.
INT16U	Accel	Motor shaft acceleration, steps/s ² (stepper motor) or RPM/s(DC). Range: 1..65535.
INT16U	Decel	Motor shaft deceleration, steps/s ² (stepper motor) or RPM/s(DC). Range: 1..65535.
INT32U	AntiplaySpeed	Speed in antiplay mode, full steps/s(stepper motor) or RPM. Range: 0..100000.
INT8U	uAntiplaySpeed	Speed in antiplay mode, 1/256 microsteps/s. Used with stepper motor only.
INT8U	Reserved [10]	Reserved (10 bytes)
INT16U	CRC	Checksum

Answer: (4 bytes)

INT32U	CMD	Command (answer)
--------	-----	------------------

Description:

Set command setup movement (speed, acceleration, threshold and etc).

Command GMOV

```
result_t get_move_settings (device_t id, move_settings_t* move_settings)
```

Command code (CMD): "gmov" or 0x766F6D67.

Request: (4 bytes)

INT32U	CMD	Command
--------	-----	---------

Answer: (30 bytes)

INT32U	CMD	Command (answer)
INT32U	Speed	Target speed (for stepper motor: steps/s, for DC: rpm). Range: 0..100000.
INT8U	uSpeed	Target speed in microstep fractions/s. Using with stepper motor only.
INT16U	Accel	Motor shaft acceleration, steps/s ² (stepper motor) or RPM/s(DC). Range: 1..65535.
INT16U	Decel	Motor shaft deceleration, steps/s ² (stepper motor) or RPM/s(DC). Range: 1..65535.
INT32U	AntiplaySpeed	Speed in antiplay mode, full steps/s(stepper motor) or RPM. Range: 0..100000.
INT8U	uAntiplaySpeed	Speed in antiplay mode, 1/256 microsteps/s. Used with stepper motor only.
INT8U	Reserved [10]	Reserved (10 bytes)
INT16U	CRC	Checksum

Description:

Read command setup movement (speed, acceleration, threshold and etc).

Command SENG

```
result_t set_engine_settings (device_t id, const engine_settings_t* engine_settings)
```

Command code (CMD): "seng" or 0x676E6573.

Request: (34 bytes)

INT32U	CMD	Command
INT16U	NomVoltage	Rated voltage in tens of mV. Controller will keep the voltage drop on motor below this value if ENGINE_LIMIT_VOLT flag is set (used with DC only).
INT16U	NomCurrent	Rated current. Controller will keep current consumed by motor below this value if ENGINE_LIMIT_CURR flag is set. Range: 15..8000
INT32U	NomSpeed	Nominal speed (in whole steps/s or rpm for DC and stepper motor as a master encoder). Controller will keep motor shaft RPM below this value if ENGINE_LIMIT_RPM flag is set. Range: 1..100000.
INT8U	uNomSpeed	The fractional part of a nominal speed in microsteps (is only used with stepper motor).
INT16U	EngineFlags	Set of flags specify motor shaft movement algorithm and list of limitations
		0x01 - ENGINE_REVERSE (Reverse flag. It determines motor shaft rotation direction that corresponds to feedback counts increasing. If not set (default), motor shaft rotation direction under positive voltage corresponds to feedback counts increasing and vice versa. Change it if you see that positive directions on motor and feedback are opposite.)
		0x02 - ENGINE_CURRENT_AS_RMS (Engine current meaning flag. If the flag is set, then engine current value is interpreted as root mean square current value. If the flag is unset, then engine current value is interpreted as maximum amplitude value.)
		0x04 - ENGINE_MAX_SPEED (Max speed flag. If it is set, engine uses maximum speed achievable with the present engine settings as nominal speed.)
		0x08 - ENGINE_ANTIPLAY (Play compensation flag. If it set, engine makes backlash (play) compensation procedure and reach the predetermined position accurately on low speed.)
		0x10 - ENGINE_ACCEL_ON (Acceleration enable flag. If it set, motion begins with acceleration and ends with deceleration.)
		0x20 - ENGINE_LIMIT_VOLT (Maximum motor voltage limit enable flag(is only used with DC motor).)
		0x40 - ENGINE_LIMIT_CURR (Maximum motor current limit enable flag(is only used with DC motor).)
		0x80 - ENGINE_LIMIT_RPM (Maximum motor speed limit enable flag.)
INT16S	Antiplay	Number of pulses or steps for backlash (play) compensation procedure. Used if ENGINE_ANTIPLAY flag is set.
INT8U	MicrostepMode	Settings of microstep mode(Used with stepper motor only).
		0x01 - MICROSTEP_MODE_FULL (Full step mode.)
		0x02 - MICROSTEP_MODE_FRAC_2 (1/2 step mode.)
		0x03 - MICROSTEP_MODE_FRAC_4 (1/4 step mode.)
		0x04 - MICROSTEP_MODE_FRAC_8 (1/8 step mode.)
		0x05 - MICROSTEP_MODE_FRAC_16 (1/16 step mode.)
		0x06 - MICROSTEP_MODE_FRAC_32 (1/32 step mode.)
		0x07 - MICROSTEP_MODE_FRAC_64 (1/64 step mode.)
		0x08 - MICROSTEP_MODE_FRAC_128 (1/128 step mode.)
		0x09 - MICROSTEP_MODE_FRAC_256 (1/256 step mode.)
INT16U	StepsPerRev	Number of full steps per revolution(Used with stepper motor only). Range: 1..65535.
INT8U	Reserved [12]	Reserved (12 bytes)
INT16U	CRC	Checksum

Answer: (4 bytes)

INT32U	CMD	Command (answer)
--------	-----	------------------

Description:

Set engine settings. This function send structure with set of engine settings to controller's memory. These settings specify motor shaft movement algorithm, list of limitations and rated characteristics. Use it when you change motor, encoder, positioner etc. Please note that wrong engine settings lead to device malfunction, can lead to irreversible damage of board.

Command GENG

```
result_t get_engine_settings (device_t id, engine_settings_t* engine_settings)
```

Command code (CMD): "geng" or 0x676E6567.

Request: (4 bytes)

INT32U	CMD	Command
--------	-----	---------

Answer: (34 bytes)

INT32U	CMD	Command (answer)
INT16U	NomVoltage	Rated voltage in tens of mV. Controller will keep the voltage drop on motor below this value if ENGINE_LIMIT_VOLT flag is set (used with DC only).
INT16U	NomCurrent	Rated current. Controller will keep current consumed by motor below this value if ENGINE_LIMIT_CURR flag is set. Range: 15..8000
INT32U	NomSpeed	Nominal speed (in whole steps/s or rpm for DC and stepper motor as a master encoder). Controller will keep motor shaft RPM below this value if ENGINE_LIMIT_RPM flag is set. Range: 1..100000.
INT8U	uNomSpeed	The fractional part of a nominal speed in microsteps (is only used with stepper motor).
INT16U	EngineFlags	Set of flags specify motor shaft movement algorithm and list of limitations
		0x01 - ENGINE_REVERSE (Reverse flag. It determines motor shaft rotation direction that corresponds to feedback counts increasing. If not set (default), motor shaft rotation direction under positive voltage corresponds to feedback counts increasing and vice versa. Change it if you see that positive directions on motor and feedback are opposite.)
		0x02 - ENGINE_CURRENT_AS_RMS (Engine current meaning flag. If the flag is set, then engine current value is interpreted as root mean square current value. If the flag is unset, then engine current value is interpreted as maximum amplitude value.)
		0x04 - ENGINE_MAX_SPEED (Max speed flag. If it is set, engine uses maximum speed achievable with the present engine settings as nominal speed.)
		0x08 - ENGINE_ANTIPLAY (Play compensation flag. If it set, engine makes backlash (play) compensation procedure and reach the predetermined position accurately on low speed.)
		0x10 - ENGINE_ACCEL_ON (Acceleration enable flag. If it set, motion begins with acceleration and ends with deceleration.)
		0x20 - ENGINE_LIMIT_VOLT (Maximum motor voltage limit enable flag(is only used with DC motor).)
		0x40 - ENGINE_LIMIT_CURR (Maximum motor current limit enable flag(is only used with DC motor).)
		0x80 - ENGINE_LIMIT_RPM (Maximum motor speed limit enable flag.)
INT16S	Antiplay	Number of pulses or steps for backlash (play) compensation procedure. Used if ENGINE_ANTIPLAY flag is set.
INT8U	MicrostepMode	Settings of microstep mode(Used with stepper motor only).
		0x01 - MICROSTEP_MODE_FULL (Full step mode.)
		0x02 - MICROSTEP_MODE_FRAC_2 (1/2 step mode.)
		0x03 - MICROSTEP_MODE_FRAC_4 (1/4 step mode.)
		0x04 - MICROSTEP_MODE_FRAC_8 (1/8 step mode.)
		0x05 - MICROSTEP_MODE_FRAC_16 (1/16 step mode.)
		0x06 - MICROSTEP_MODE_FRAC_32 (1/32 step mode.)
		0x07 - MICROSTEP_MODE_FRAC_64 (1/64 step mode.)
		0x08 - MICROSTEP_MODE_FRAC_128 (1/128 step mode.)
		0x09 - MICROSTEP_MODE_FRAC_256 (1/256 step mode.)
INT16U	StepsPerRev	Number of full steps per revolution(Used with stepper motor only). Range: 1..65535.
INT8U	Reserved [12]	Reserved (12 bytes)
INT16U	CRC	Checksum

Description:

Read engine settings. This function fill structure with set of useful motor settings stored in controller's memory. These settings specify motor shaft movement algorithm, list of limitations and rated characteristics.

Command SENT

```
result_t set_entype_settings (device_t id, const entype_settings_t* entype_settings)
```

Command code (CMD): "sent" or 0x746E6573.

Request: (14 bytes)

INT32U	CMD	Command
INT8U	EngineType	Engine type
		0x00 - ENGINE_TYPE_NONE (A value that shouldn't be used.)
		0x01 - ENGINE_TYPE_DC (DC motor.)
		0x02 - ENGINE_TYPE_2DC (2 DC motors.)
		0x03 - ENGINE_TYPE_STEP (Step motor.)
		0x04 - ENGINE_TYPE_TEST (Duty cycle are fixed. Used only manufacturer.)
		0x05 - ENGINE_TYPE_BRUSHLESS (Brushless motor.)
INT8U	DriverType	Driver type
		0x01 - DRIVER_TYPE_DISCRETE_FET (Driver with discrete FET keys. Default option.)
		0x02 - DRIVER_TYPE_INTEGRATE (Driver with integrated IC.)
		0x03 - DRIVER_TYPE_EXTERNAL (External driver.)
INT8U	Reserved [6]	Reserved (6 bytes)
INT16U	CRC	Checksum

Answer: (4 bytes)

INT32U	CMD	Command (answer)
--------	-----	------------------

Description:

Set engine type and driver type.

Command GENT

```
result_t get_entype_settings (device_t id, entype_settings_t* entype_settings)
```

Command code (CMD): "gent" or 0x7446E6567.

Request: (4 bytes)

INT32U	CMD	Command
--------	-----	---------

Answer: (14 bytes)

INT32U	CMD	Command (answer)
INT8U	EngineType	Engine type
		0x00 - ENGINE_TYPE_NONE (A value that shouldn't be used.)
		0x01 - ENGINE_TYPE_DC (DC motor.)
		0x02 - ENGINE_TYPE_2DC (2 DC motors.)
		0x03 - ENGINE_TYPE_STEP (Step motor.)
		0x04 - ENGINE_TYPE_TEST (Duty cycle are fixed. Used only manufacturer.)
		0x05 - ENGINE_TYPE_BRUSHLESS (Brushless motor.)
INT8U	DriverType	Driver type
		0x01 - DRIVER_TYPE_DISCRETE_FET (Driver with discrete FET keys. Default option.)
		0x02 - DRIVER_TYPE_INTEGRATE (Driver with integrated IC.)
		0x03 - DRIVER_TYPE_EXTERNAL (External driver.)
INT8U	Reserved [6]	Reserved (6 bytes)
INT16U	CRC	Checksum

Description:

Return engine type and driver type.

Command SPWR

```
result_t set_power_settings (device_t id, const power_settings_t* power_settings)
```

Command code (CMD): "spwr" or 0x72777073.

Request: (20 bytes)

INT32U	CMD	Command
INT8U	HoldCurrent	Current in holding regime, percent of nominal. Range: 0..100.
INT16U	CurrReductDelay	Time in ms from going to STOP state to reducing current.
INT16U	PowerOffDelay	Time in s from going to STOP state to turning power off.
INT16U	CurrentSetTime	Time in ms to reach nominal current.
INT8U	PowerFlags	Flags with parameters of power control.
		0x01 - POWER_REDUCT_ENABLED (Current reduction enabled after CurrReductDelay, if this flag is set.)
		0x02 - POWER_OFF_ENABLED (Power off enabled after PowerOffDelay, if this flag is set.)
		0x04 - POWER_SMOOTH_CURRENT (Current ramp-up/down is performed smoothly during current_set_time, if this flag is set.)
INT8U	Reserved [6]	Reserved (6 bytes)
INT16U	CRC	Checksum

Answer: (4 bytes)

INT32U	CMD	Command (answer)
--------	-----	------------------

Description:

Set settings of step motor power control. Used with stepper motor only.

Command GPWR

```
result_t get_power_settings (device_t id, power_settings_t* power_settings)
```

Command code (CMD): "gpwr" or 0x72777067.

Request: (4 bytes)

INT32U	CMD	Command
--------	-----	---------

Answer: (20 bytes)

INT32U	CMD	Command (answer)
INT8U	HoldCurrent	Current in holding regime, percent of nominal. Range: 0..100.
INT16U	CurrReductDelay	Time in ms from going to STOP state to reducing current.
INT16U	PowerOffDelay	Time in s from going to STOP state to turning power off.
INT16U	CurrentSetTime	Time in ms to reach nominal current.
INT8U	PowerFlags	Flags with parameters of power control.
		0x01 - POWER_REDUCT_ENABLED (Current reduction enabled after CurrReductDelay, if this flag is set.)
		0x02 - POWER_OFF_ENABLED (Power off enabled after PowerOffDelay, if this flag is set.)
		0x04 - POWER_SMOOTH_CURRENT (Current ramp-up/down is performed smoothly during current_set_time, if this flag is set.)
INT8U	Reserved [6]	Reserved (6 bytes)
INT16U	CRC	Checksum

Description:

Read settings of step motor power control. Used with stepper motor only.

Command SSEC

```
result_t set_secure_settings (device_t id, const secure_settings_t* secure_settings)
```

Command code (CMD): "ssec" or 0x63657373.

Request: (28 bytes)

INT32U	CMD	Command
INT16U	LowUpwrOff	Lower voltage limit to turn off the motor, tens of mV.
INT16U	CriticalIpwr	Maximum motor current which triggers ALARM state, in mA.
INT16U	CriticalUpwr	Maximum motor voltage which triggers ALARM state, tens of mV.
INT16U	CriticalT	Maximum temperature, which triggers ALARM state, in tenths of degrees Celcius.
INT16U	CriticalIusb	Maximum USB current which triggers ALARM state, in mA.
INT16U	CriticalUusb	Maximum USB voltage which triggers ALARM state, tens of mV.
INT16U	MinimumUusb	Minimum USB voltage which triggers ALARM state, tens of mV.
INT8U	Flags	Critical parameter flags.
		0x01 - ALARM_ON_DRIVER_OVERHEATING (If this flag is set enter Alarm state on driver overheat signal.)
		0x02 - LOW_UPWR_PROTECTION (If this flag is set turn off motor when voltage is lower than LowUpwrOff.)
		0x04 - H_BRIDGE_ALERT (If this flag is set then turn off the power unit with a signal problem in one of the transistor bridge.)
		0x08 - ALARM_ON_BORDERS_SWAP_MISSET (If this flag is set enter Alarm state on borders swap misset)
		0x10 - ALARM_FLAGS_STICKING (If this flag is set only a STOP command can turn all alarms to 0)
		0x20 - USB_BREAK_RECONNECT (If this flag is set USB brake reconnect module will be enable)
INT8U	Reserved [7]	Reserved (7 bytes)
INT16U	CRC	Checksum

Answer: (4 bytes)

INT32U	CMD	Command (answer)
--------	-----	------------------

Description:

Set protection settings.

Command GSEC

```
result_t get_secure_settings (device_t id, secure_settings_t* secure_settings)
```

Command code (CMD): "gsec" or 0x63657367.

Request: (4 bytes)

INT32U	CMD	Command
--------	-----	---------

Answer: (28 bytes)

INT32U	CMD	Command (answer)
INT16U	LowUpwrOff	Lower voltage limit to turn off the motor, tens of mV.
INT16U	CriticalIpwr	Maximum motor current which triggers ALARM state, in mA.
INT16U	CriticalUpwr	Maximum motor voltage which triggers ALARM state, tens of mV.
INT16U	CriticalT	Maximum temperature, which triggers ALARM state, in tenths of degrees Celcius.
INT16U	CriticalIusb	Maximum USB current which triggers ALARM state, in mA.
INT16U	CriticalUusb	Maximum USB voltage which triggers ALARM state, tens of mV.
INT16U	MinimumUusb	Minimum USB voltage which triggers ALARM state, tens of mV.
INT8U	Flags	Critical parameter flags.
		0x01 - ALARM_ON_DRIVER_OVERHEATING (If this flag is set enter Alarm state on driver overheat signal.)
		0x02 - LOW_UPWR_PROTECTION (If this flag is set turn off motor when voltage is lower than LowUpwrOff.)
		0x04 - H_BRIDGE_ALERT (If this flag is set then turn off the power unit with a signal problem in one of the transistor bridge.)
		0x08 - ALARM_ON_BORDERS_SWAP_MISSET (If this flag is set enter Alarm state on borders swap misset)
		0x10 - ALARM_FLAGS_STICKING (If this flag is set only a STOP command can turn all alarms to 0)
		0x20 - USB_BREAK_RECONNECT (If this flag is set USB brake reconnect module will be enable)
INT8U	Reserved [7]	Reserved (7 bytes)
INT16U	CRC	Checksum

Description:

Read protection settings.

Command SEDS

```
result_t set_edges_settings (device_t id, const edges_settings_t* edges_settings)
```

Command code (CMD): "seds" or 0x73646573.

Request: (26 bytes)

INT32U	CMD	Command
INT8U	BorderFlags	Border flags, specify types of borders and motor behaviour on borders. 0x01 - BORDER_IS_ENCODER (Borders are fixed by predetermined encoder values, if set; borders position on limit switches, if not set.) 0x02 - BORDER_STOP_LEFT (Motor should stop on left border.) 0x04 - BORDER_STOP_RIGHT (Motor should stop on right border.) 0x08 - BORDERS_SWAP_MISSET_DETECTION (Motor should stop on both borders. Need to save motor then wrong border settings is se)
INT8U	EnderFlags	Ender flags, specify electrical behaviour of limit switches like order and pulled positions. 0x01 - ENDER_SWAP (First limit switch on the right side, if set; otherwise on the left side.) 0x02 - ENDER_SW1_ACTIVE_LOW (1 - Limit switch connected to pin SW1 is triggered by a low level on pin.) 0x04 - ENDER_SW2_ACTIVE_LOW (1 - Limit switch connected to pin SW2 is triggered by a low level on pin.)
INT32S	LeftBorder	Left border position, used if BORDER_IS_ENCODER flag is set.
INT16S	uLeftBorder	Left border position in 1/256 microsteps(used with stepper motor only). Range: -255..255.
INT32S	RightBorder	Right border position, used if BORDER_IS_ENCODER flag is set.
INT16S	uRightBorder	Right border position in 1/256 microsteps. Used with stepper motor only. Range: -255..255.
INT8U	Reserved [6]	Reserved (6 bytes)
INT16U	CRC	Checksum

Answer: (4 bytes)

INT32U	CMD	Command (answer)
--------	-----	------------------

Description:

Set border and limit switches settings.

Command GEDS

```
result_t get_edges_settings (device_t id, edges_settings_t* edges_settings)
```

Command code (CMD): "geds" or 0x73646567.

Request: (4 bytes)

INT32U	CMD	Command
--------	-----	---------

Answer: (26 bytes)

INT32U	CMD	Command (answer)
INT8U	BorderFlags	Border flags, specify types of borders and motor behaviour on borders.
		0x01 - BORDER_IS_ENCODER (Borders are fixed by predetermined encoder values, if set; borders position on limit switches, if not set.)
		0x02 - BORDER_STOP_LEFT (Motor should stop on left border.)
		0x04 - BORDER_STOP_RIGHT (Motor should stop on right border.)
		0x08 - BORDERS_SWAP_MISSET_DETECTION (Motor should stop on both borders. Need to save motor then wrong border settings is se)
INT8U	EnderFlags	Ender flags, specify electrical behaviour of limit switches like order and pulled positions.
		0x01 - ENDER_SWAP (First limit switch on the right side, if set; otherwise on the left side.)
		0x02 - ENDER_SW1_ACTIVE_LOW (1 - Limit switch connected to pin SW1 is triggered by a low level on pin.)
		0x04 - ENDER_SW2_ACTIVE_LOW (1 - Limit switch connected to pin SW2 is triggered by a low level on pin.)
INT32S	LeftBorder	Left border position, used if BORDER_IS_ENCODER flag is set.
INT16S	uLeftBorder	Left border position in 1/256 microsteps(used with stepper motor only). Range: -255..255.
INT32S	RightBorder	Right border position, used if BORDER_IS_ENCODER flag is set.
INT16S	uRightBorder	Right border position in 1/256 microsteps. Used with stepper motor only. Range: -255..255.
INT8U	Reserved [6]	Reserved (6 bytes)
INT16U	CRC	Checksum

Description:

Read border and limit switches settings.

Command SPID

```
result_t set_pid_settings (device_t id, const pid_settings_t* pid_settings)
```

Command code (CMD): "spid" or 0x64697073.

Request: (48 bytes)

INT32U	CMD	Command
INT16U	KpU	Proportional gain for voltage PID routine
INT16U	KiU	Integral gain for voltage PID routine
INT16U	KdU	Differential gain for voltage PID routine
FLT32	Kpf	Proportional gain for BLDC position PID routine
FLT32	Kif	Integral gain for BLDC position PID routine
FLT32	Kdf	Differential gain for BLDC position PID routine
INT8U	Reserved [24]	Reserved (24 bytes)
INT16U	CRC	Checksum

Answer: (4 bytes)

INT32U	CMD	Command (answer)
--------	-----	------------------

Description:

Set PID settings. This function send structure with set of PID factors to controller's memory. These settings specify behaviour of PID routine for positioner. These factors are slightly different for different positioners. All boards are supplied with standard set of PID setting on controller's flash memory. Please use it for loading new PID settings when you change positioner. Please note that wrong PID settings lead to device malfunction.

Command GPID

```
result_t get_pid_settings (device_t id, pid_settings_t* pid_settings)
```

Command code (CMD): "gpid" or 0x64697067.

Request: (4 bytes)

INT32U	CMD	Command
--------	-----	---------

Answer: (48 bytes)

INT32U	CMD	Command (answer)
INT16U	KpU	Proportional gain for voltage PID routine
INT16U	KiU	Integral gain for voltage PID routine
INT16U	KdU	Differential gain for voltage PID routine
FLT32	Kpf	Proportional gain for BLDC position PID routine
FLT32	Kif	Integral gain for BLDC position PID routine
FLT32	Kdf	Differential gain for BLDC position PID routine
INT8U	Reserved [24]	Reserved (24 bytes)
INT16U	CRC	Checksum

Description:

Read PID settings. This function fill structure with set of motor PID settings stored in controller's memory. These settings specify behaviour of PID routine for positioner. These factors are slightly different for different positioners. All boards are supplied with standard set of PID setting on controller's flash memory.

Command SSNI

```
result_t set_sync_in_settings (device_t id, const sync_in_settings_t* sync_in_settings)
```

Command code (CMD): "ssni" or 0x696E7373.

Request: (28 bytes)

INT32U	CMD	Command
INT8U	SyncInFlags	Input synchronization flags
		0x01 - SYNCIN_ENABLED (Synchronization in mode is enabled, if this flag is set.)
		0x02 - SYNCIN_INVERT (Trigger on falling edge if flag is set, on rising edge otherwise.)
		0x04 - SYNCIN_GOTOPOSITION (The engine is go to position specified in Position and uPosition, if this flag is set. And it is shift on the Position and uPosition, if this flag is unset)
INT16U	ClutterTime	Input synchronization pulse dead time (mks).
INT32S	Position	Desired position or shift (whole steps)
INT16S	uPosition	The fractional part of a position or shift in microsteps. Is used with stepper motor. Range: -255..255.
INT32U	Speed	Target speed (for stepper motor: steps/s, for DC: rpm). Range: 0..100000.
INT8U	uSpeed	Target speed in microsteps/s. Using with stepper motor only.
INT8U	Reserved [8]	Reserved (8 bytes)
INT16U	CRC	Checksum

Answer: (4 bytes)

INT32U	CMD	Command (answer)
--------	-----	------------------

Description:

Set input synchronization settings. This function send structure with set of input synchronization settings, that specify behaviour of input synchronization, to controller's memory. All boards are supplied with standard set of these settings.

Command GSNI

```
result_t get_sync_in_settings (device_t id, sync_in_settings_t* sync_in_settings)
```

Command code (CMD): "gsni" or 0x696E7367.

Request: (4 bytes)

INT32U	CMD	Command
--------	-----	---------

Answer: (28 bytes)

INT32U	CMD	Command (answer)
INT8U	SyncInFlags	Input synchronization flags
		0x01 - SYNCIN_ENABLED (Synchronization in mode is enabled, if this flag is set.)
		0x02 - SYNCIN_INVERT (Trigger on falling edge if flag is set, on rising edge otherwise.)
		0x04 - SYNCIN_GOTOPOSITION (The engine is go to position specified in Position and uPosition, if this flag is set. And it is shift on the Position and uPosition, if this flag is unset)
INT16U	ClutterTime	Input synchronization pulse dead time (mks).
INT32S	Position	Desired position or shift (whole steps)
INT16S	uPosition	The fractional part of a position or shift in microsteps. Is used with stepper motor. Range: -255..255.
INT32U	Speed	Target speed (for stepper motor: steps/s, for DC: rpm). Range: 0..100000.
INT8U	uSpeed	Target speed in microsteps/s. Using with stepper motor only.
INT8U	Reserved [8]	Reserved (8 bytes)
INT16U	CRC	Checksum

Description:

Read input synchronization settings. This function fill structure with set of input synchronization settings, modes, periods and flags, that specify behaviour of input synchronization. All boards are supplied with standard set of these settings.

Command SSNO

```
result_t set_sync_out_settings (device_t id, const sync_out_settings_t* sync_out_settings)
```

Command code (CMD): "ssno" or 0x6F6E7373.

Request: (16 bytes)

INT32U	CMD	Command
INT8U	SyncOutFlags	Output synchronization flags
		0x01 - SYNCOUT_ENABLED (Synchronization out pin follows the synchronization logic, if set. It governed by SYNCOUT_STATE flag otherwise.)
		0x02 - SYNCOUT_STATE (When output state is fixed by negative SYNCOUT_ENABLED flag, the pin state is in accordance with this flag state.)
		0x04 - SYNCOUT_INVERT (Low level is active, if set, and high level is active otherwise.)
		0x08 - SYNCOUT_IN_STEPS (Use motor steps/encoder pulses instead of milliseconds for output pulse generation if the flag is set.)
		0x10 - SYNCOUT_ONSTART (Generate synchronization pulse when movement starts.)
		0x20 - SYNCOUT_ONSTOP (Generate synchronization pulse when movement stops.)
		0x40 - SYNCOUT_ONPERIOD (Generate synchronization pulse every SyncOutPeriod encoder pulses.)
INT16U	SyncOutPulseSteps	This value specifies duration of output pulse. It is measured microseconds when SYNCOUT_IN_STEPS flag is cleared or in encoder pulses or motor steps when SYNCOUT_IN_STEPS is set.
INT16U	SyncOutPeriod	This value specifies number of encoder pulses or steps between two output synchronization pulses when SYNCOUT_ONPERIOD is set.
INT32U	Accuracy	This is the neighborhood around the target coordinates, which is getting hit in the target position and the momentum generated by the stop.
INT8U	uAccuracy	This is the neighborhood around the target coordinates in micro steps (only used with stepper motor).
INT16U	CRC	Checksum

Answer: (4 bytes)

INT32U	CMD	Command (answer)
--------	-----	------------------

Description:

Set output synchronization settings. This function send structure with set of output synchronization settings, that specify behaviour of output synchronization, to controller's memory. All boards are supplied with standard set of these settings.

Command GSNO

```
result_t get_sync_out_settings (device_t id, sync_out_settings_t* sync_out_settings)
```

Command code (CMD): "gsno" or 0x6F6E7367.

Request: (4 bytes)

INT32U	CMD	Command
--------	-----	---------

Answer: (16 bytes)

INT32U	CMD	Command (answer)
INT8U	SyncOutFlags	Output synchronization flags
		0x01 - SYNCOUT_ENABLED (Synchronization out pin follows the synchronization logic, if set. It governed by SYNCOUT_STATE flag otherwise.)
		0x02 - SYNCOUT_STATE (When output state is fixed by negative SYNCOUT_ENABLED flag, the pin state is in accordance with this flag state.)
		0x04 - SYNCOUT_INVERT (Low level is active, if set, and high level is active otherwise.)
		0x08 - SYNCOUT_IN_STEPS (Use motor steps/encoder pulses instead of milliseconds for output pulse generation if the flag is set.)
		0x10 - SYNCOUT_ONSTART (Generate synchronization pulse when movement starts.)
		0x20 - SYNCOUT_ONSTOP (Generate synchronization pulse when movement stops.)
		0x40 - SYNCOUT_ONPERIOD (Generate synchronization pulse every SyncOutPeriod encoder pulses.)
INT16U	SyncOutPulseSteps	This value specifies duration of output pulse. It is measured microseconds when SYNCOUT_IN_STEPS flag is cleared or in encoder pulses or motor steps when SYNCOUT_IN_STEPS is set.
INT16U	SyncOutPeriod	This value specifies number of encoder pulses or steps between two output synchronization pulses when SYNCOUT_ONPERIOD is set.
INT32U	Accuracy	This is the neighborhood around the target coordinates, which is getting hit in the target position and the momentum generated by the stop.
INT8U	uAccuracy	This is the neighborhood around the target coordinates in micro steps (only used with stepper motor).
INT16U	CRC	Checksum

Description:

Read output synchronization settings. This function fill structure with set of output synchronization settings, modes, periods and flags, that specify behaviour of output synchronization. All boards are supplied with standard set of these settings.

Command SEIO

```
result_t set_extio_settings (device_t id, const extio_settings_t* extio_settings)
```

Command code (CMD): "seio" or 0x6F696573.

Request: (18 bytes)

INT32U	CMD	Command
INT8U	EXTIOSetupFlags	Configuration flags of the external I-O
		0x01 - EXTIO_SETUP_OUTPUT (EXTIO works as output if flag is set, works as input otherwise.)
		0x02 - EXTIO_SETUP_INVERT (Interpret EXTIO states and fronts inverted if flag is set. Falling front as input event and low logic level as active state.)
INT8U	EXTIOModeFlags	Flags mode settings external I-O
		0x0F - EXTIO_SETUP_MODE_IN_BITS (Bits of the behaviour selector when the signal on input goes to the active state.)
		0x00 - EXTIO_SETUP_MODE_IN_NOP (Do nothing.)
		0x01 - EXTIO_SETUP_MODE_IN_STOP (Issue STOP command, ceasing the engine movement.)
		0x02 - EXTIO_SETUP_MODE_IN_PWOF (Issue PWOF command, powering off all engine windings.)
		0x03 - EXTIO_SETUP_MODE_IN_MOVR (Issue MOVR command with last used settings.)
		0x04 - EXTIO_SETUP_MODE_IN_HOME (Issue HOME command.)
		0x05 - EXTIO_SETUP_MODE_IN_ALARM (Set Alarm when the signal goes to the active state.)
		0xF0 - EXTIO_SETUP_MODE_OUT_BITS (Bits of the output behaviour selection.)
		0x00 - EXTIO_SETUP_MODE_OUT_OFF (EXTIO pin always set in inactive state.)
		0x10 - EXTIO_SETUP_MODE_OUT_ON (EXTIO pin always set in active state.)
		0x20 - EXTIO_SETUP_MODE_OUT_MOVING (EXTIO pin stays active during moving state.)
		0x30 - EXTIO_SETUP_MODE_OUT_ALARM (EXTIO pin stays active during Alarm state.)
		0x40 - EXTIO_SETUP_MODE_OUT_MOTOR_ON (EXTIO pin stays active when windings are powered.)
		0x50 - EXTIO_SETUP_MODE_OUT_MOTOR_FOUND (EXTIO pin stays active when motor is connected (first winding).)
INT8U	Reserved [10]	Reserved (10 bytes)
INT16U	CRC	Checksum

Answer: (4 bytes)

INT32U	CMD	Command (answer)
--------	-----	------------------

Description:

Set EXTIO settings. This function writes a structure with a set of EXTIO settings to controller's memory. By default input event are signalled through rising front and output states are signalled by high logic state.

Command GEIO

```
result_t get_extio_settings (device_t id, extio_settings_t* extio_settings)
```

Command code (CMD): "geio" or 0x6F696567.

Request: (4 bytes)

INT32U	CMD	Command
--------	-----	---------

Answer: (18 bytes)

INT32U	CMD	Command (answer)
INT8U	EXTIOSetupFlags	Configuration flags of the external I-O
		0x01 - EXTIO_SETUP_OUTPUT (EXTIO works as output if flag is set, works as input otherwise.)
		0x02 - EXTIO_SETUP_INVERT (Interpret EXTIO states and fronts inverted if flag is set. Falling front as input event and low logic level as active state.)
INT8U	EXTIOModeFlags	Flags mode settings external I-O
		0x0F - EXTIO_SETUP_MODE_IN_BITS (Bits of the behaviour selector when the signal on input goes to the active state.)
		0x00 - EXTIO_SETUP_MODE_IN_NOP (Do nothing.)
		0x01 - EXTIO_SETUP_MODE_IN_STOP (Issue STOP command, ceasing the engine movement.)
		0x02 - EXTIO_SETUP_MODE_IN_PWOF (Issue PWOF command, powering off all engine windings.)
		0x03 - EXTIO_SETUP_MODE_IN_MOVR (Issue MOVR command with last used settings.)
		0x04 - EXTIO_SETUP_MODE_IN_HOME (Issue HOME command.)
		0x05 - EXTIO_SETUP_MODE_IN_ALARM (Set Alarm when the signal goes to the active state.)
		0xF0 - EXTIO_SETUP_MODE_OUT_BITS (Bits of the output behaviour selection.)
		0x00 - EXTIO_SETUP_MODE_OUT_OFF (EXTIO pin always set in inactive state.)
		0x10 - EXTIO_SETUP_MODE_OUT_ON (EXTIO pin always set in active state.)
		0x20 - EXTIO_SETUP_MODE_OUT_MOVING (EXTIO pin stays active during moving state.)
		0x30 - EXTIO_SETUP_MODE_OUT_ALARM (EXTIO pin stays active during Alarm state.)
		0x40 - EXTIO_SETUP_MODE_OUT_MOTOR_ON (EXTIO pin stays active when windings are powered.)
		0x50 - EXTIO_SETUP_MODE_OUT_MOTOR_FOUND (EXTIO pin stays active when motor is connected (first winding).)
INT8U	Reserved [10]	Reserved (10 bytes)
INT16U	CRC	Checksum

Description:

Read EXTIO settings. This function reads a structure with a set of EXTIO settings from controller's memory.

Command SBRK

```
result_t set_brake_settings (device_t id, const brake_settings_t* brake_settings)
```

Command code (CMD): "sbrk" or 0x6B726273.

Request: (25 bytes)

INT32U	CMD	Command
INT16U	t1	Time in ms between turn on motor power and turn off brake.
INT16U	t2	Time in ms between turn off brake and moving readiness. All moving commands will execute after this interval.
INT16U	t3	Time in ms between motor stop and turn on brake.
INT16U	t4	Time in ms between turn on brake and turn off motor power.
INT8U	BrakeFlags	Flags.
		0x01 - BRAKE_ENABLED (Brake control is enabled, if this flag is set.)
		0x02 - BRAKE_ENG_PWROFF (Brake turns off power of step motor, if this flag is set.)
INT8U	Reserved [10]	Reserved (10 bytes)
INT16U	CRC	Checksum

Answer: (4 bytes)

INT32U	CMD	Command (answer)
--------	-----	------------------

Description:

Set settings of brake control.

Command GBRK

```
result_t get_brake_settings (device_t id, brake_settings_t* brake_settings)
```

Command code (CMD): "gbrk" or 0x6B726267.

Request: (4 bytes)

INT32U	CMD	Command
--------	-----	---------

Answer: (25 bytes)

INT32U	CMD	Command (answer)
INT16U	t1	Time in ms between turn on motor power and turn off brake.
INT16U	t2	Time in ms between turn off brake and moving readiness. All moving commands will execute after this interval.
INT16U	t3	Time in ms between motor stop and turn on brake.
INT16U	t4	Time in ms between turn on brake and turn off motor power.
INT8U	BrakeFlags	Flags.
		0x01 - BRAKE_ENABLED (Brake control is enabled, if this flag is set.)
		0x02 - BRAKE_ENG_PWROFF (Brake turns off power of step motor, if this flag is set.)
INT8U	Reserved [10]	Reserved (10 bytes)
INT16U	CRC	Checksum

Description:

Read settings of brake control.

Command SCTL

```
result_t set_control_settings (device_t id, const control_settings_t* control_settings)
```

Command code (CMD): "sctl" or 0x6C746373.

Request: (93 bytes)

INT32U	CMD	Command
INT32U	MaxSpeed [10]	Array of speeds (full step) using with joystick and button control. Range: 0..100000.
INT8U	uMaxSpeed [10]	Array of speeds (1/256 microstep) using with joystick and button control.
INT16U	Timeout [9]	timeout[i] is time in ms, after that max_speed[i+1] is applying. It is using with buttons control only.
INT16U	MaxClickTime	Maximum click time. Prior to the expiration of this time the first speed isn't enabled.
INT16U	Flags	Flags.
		0x03 - CONTROL_MODE_BITS (Bits to control engine by joystick or buttons.)
		0x00 - CONTROL_MODE_OFF (Control is disabled.)
		0x01 - CONTROL_MODE_JOY (Control by joystick.)
		0x02 - CONTROL_MODE_LR (Control by left/right buttons.)
		0x04 - CONTROL_BTN_LEFT_PUSHED_OPEN (Pushed left button corresponds to open contact, if this flag is set.)
		0x08 - CONTROL_BTN_RIGHT_PUSHED_OPEN (Pushed right button corresponds to open contact, if this flag is set.)
INT32S	DeltaPosition	Shift (delta) of position
INT16S	uDeltaPosition	Fractional part of the shift in micro steps. Is only used with stepper motor. Range: -255..255.
INT8U	Reserved [9]	Reserved (9 bytes)
INT16U	CRC	Checksum

Answer: (4 bytes)

INT32U	CMD	Command (answer)
--------	-----	------------------

Description:

Set settings of motor control. When choosing CTL_MODE = 1 switches motor control with the joystick. In this mode, the joystick to the maximum engine tends Move at MaxSpeed [i], where i = 0 if the previous use This mode is not selected another i. Buttons switch the room rate i. When CTL_MODE = 2 is switched on motor control using the Left / right. When you click on the button motor starts to move in the appropriate direction at a speed MaxSpeed [0], at the end of time Timeout [i] motor move at a speed MaxSpeed [i+1]. at Transition from MaxSpeed [i] on MaxSpeed [i +1] to acceleration, as usual.

Command GCTL

```
result_t get_control_settings (device_t id, control_settings_t* control_settings)
```

Command code (CMD): "gctl" or 0x6C746367.

Request: (4 bytes)

INT32U	CMD	Command
--------	-----	---------

Answer: (93 bytes)

INT32U	CMD	Command (answer)
INT32U	MaxSpeed [10]	Array of speeds (full step) using with joystick and button control. Range: 0..100000.
INT8U	uMaxSpeed [10]	Array of speeds (1/256 microstep) using with joystick and button control.
INT16U	Timeout [9]	timeout[i] is time in ms, after that max_speed[i+1] is applying. It is using with buttons control only.
INT16U	MaxClickTime	Maximum click time. Prior to the expiration of this time the first speed isn't enabled.
INT16U	Flags	Flags.
		0x03 - CONTROL_MODE_BITS (Bits to control engine by joystick or buttons.)
		0x00 - CONTROL_MODE_OFF (Control is disabled.)
		0x01 - CONTROL_MODE_JOY (Control by joystick.)
		0x02 - CONTROL_MODE_LR (Control by left/right buttons.)
		0x04 - CONTROL_BTN_LEFT_PUSHED_OPEN (Pushed left button corresponds to open contact, if this flag is set.)
		0x08 - CONTROL_BTN_RIGHT_PUSHED_OPEN (Pushed right button corresponds to open contact, if this flag is set.)
INT32S	DeltaPosition	Shift (delta) of position
INT16S	uDeltaPosition	Fractional part of the shift in micro steps. Is only used with stepper motor. Range: -255..255.
INT8U	Reserved [9]	Reserved (9 bytes)
INT16U	CRC	Checksum

Description:

Read settings of motor control. When choosing CTL_MODE = 1 switches motor control with the joystick. In this mode, the joystick to the maximum engine tends Move at MaxSpeed [i], where i = 0 if the previous use This mode is not selected another i. Buttons switch the room rate i. When CTL_MODE = 2 is switched on motor control using the Left / right. When you click on the button motor starts to move in the appropriate direction at a speed MaxSpeed [0], at the end of time Timeout [i] motor move at a speed MaxSpeed [i+1]. at Transition from MaxSpeed [i] on MaxSpeed [i +1] to acceleration, as usual.

Command SJOY

```
result_t set_joystick_settings (device_t id, const joystick_settings_t* joystick_settings)
```

Command code (CMD): "sjoy" or 0x796F6A73.

Request: (22 bytes)

INT32U	CMD	Command
INT16U	JoyLowEnd	Joystick lower end position. Range: 0..10000.
INT16U	JoyCenter	Joystick center position. Range: 0..10000.
INT16U	JoyHighEnd	Joystick higher end position. Range: 0..10000.
INT8U	ExpFactor	Exponential nonlinearity factor.
INT8U	DeadZone	Joystick dead zone.
INT8U	JoyFlags	Joystick control flags.
		0x01 - JOY_REVERSE (Joystick action is reversed. Joystick deviation to the upper values correspond to negative speeds and vice versa.)
INT8U	Reserved [7]	Reserved (7 bytes)
INT16U	CRC	Checksum

Answer: (4 bytes)

INT32U	CMD	Command (answer)
--------	-----	------------------

Description:

Set settings of joystick. If joystick position is outside DeadZone limits from the central position a movement with speed, defined by the joystick DeadZone edge to 100% deviation, begins. Joystick positions inside DeadZone limits correspond to zero speed (soft stop of motion) and positions beyond Low and High limits correspond MaxSpeed [i] or -MaxSpeed [i] (see command SCTL), where i = 0 by default and can be changed with left/right buttons (see command SCTL). If next speed in list is zero (both integer and microstep parts), the button press is ignored. First speed in list shouldn't be zero. The DeadZone ranges are illustrated on the following picture.

□ The relationship between the deviation and the rate is exponential, allowing no switching speed combine high mobility and accuracy. The following picture illustrates this:

□ The nonlinearity parameter is adjustable. Setting it to zero makes deviation/speed relation linear.

Command GJOY

```
result_t get_joystick_settings (device_t id, joystick_settings_t* joystick_settings)
```

Command code (CMD): "gjoy" or 0x796F6A67.

Request: (4 bytes)

INT32U	CMD	Command
--------	-----	---------

Answer: (22 bytes)

INT32U	CMD	Command (answer)
INT16U	JoyLowEnd	Joystick lower end position. Range: 0..10000.
INT16U	JoyCenter	Joystick center position. Range: 0..10000.
INT16U	JoyHighEnd	Joystick higher end position. Range: 0..10000.
INT8U	ExpFactor	Exponential nonlinearity factor.
INT8U	DeadZone	Joystick dead zone.
INT8U	JoyFlags	Joystick control flags.
		0x01 - JOY_REVERSE (Joystick action is reversed. Joystick deviation to the upper values correspond to negative speeds and vice versa.)
INT8U	Reserved [7]	Reserved (7 bytes)
INT16U	CRC	Checksum

Description:

Read settings of joystick. If joystick position is outside DeadZone limits from the central position a movement with speed, defined by the joystick DeadZone edge to 100% deviation, begins. Joystick positions inside DeadZone limits correspond to zero speed (soft stop of motion) and positions beyond Low and High limits correspond MaxSpeed [i] or -MaxSpeed [i] (see command SCTL), where i = 0 by default and can be changed with left/right buttons (see command SCTL). If next speed in list is zero (both integer and microstep parts), the button press is ignored. First speed in list shouldn't be zero. The DeadZone ranges are illustrated on the following picture.

□ The relationship between the deviation and the rate is exponential, allowing no switching speed combine high mobility and accuracy. The following picture illustrates this:

□ The nonlinearity parameter is adjustable. Setting it to zero makes deviation/speed relation linear.

Command SCTP

```
result_t set_ctp_settings (device_t id, const ctp_settings_t* ctp_settings)
```

Command code (CMD): "sctp" or 0x70746373.

Request: (18 bytes)

INT32U	CMD	Command
INT8U	CTPMinError	Minimum contrast steps from step motor encoder position, wich set STATE_CTP_ERROR flag. Measured in steps step motor.
INT8U	CTPFlags	Flags.
		0x01 - CTP_ENABLED (Position control is enabled, if flag set.)
		0x02 - CTP_BASE (Position control is based on revolution sensor, if this flag is set; otherwise it is based on encoder.)
		0x04 - CTP_ALARM_ON_ERROR (Set ALARM on mismatch, if flag set.)
		0x08 - REV_SENS_INV (Sensor is active when it 0 and invert makes active level 1. That is, if you do not invert, it is normal logic - 0 is the activation.)
		0x10 - CTP_ERROR_CORRECTION (Correct errors which appear when slippage if the flag is set. It works only with the encoder. Incompatible with flag CTP_ALARM_ON_ERROR.)
INT8U	Reserved [10]	Reserved (10 bytes)
INT16U	CRC	Checksum

Answer: (4 bytes)

INT32U	CMD	Command (answer)
--------	-----	------------------

Description:

Set settings of control position(is only used with stepper motor). When controlling the step motor with encoder (CTP_BASE 0) it is possible to detect the loss of steps. The controller knows the number of steps per revolution (GENG :: StepsPerRev) and the encoder resolution (GFBS :: IPT). When the control (flag CTP_ENABLED), the controller stores the current position in the footsteps of SM and the current position of the encoder. Further, at each step of the position encoder is converted into steps and if the difference is greater CTPMinError, a flag STATE_CTP_ERROR. When controlling the step motor with speed sensor (CTP_BASE 1), the position is controlled by him. The active edge of input clock controller stores the current value of steps. Further, at each turn checks how many steps shifted. When a mismatch CTPMinError a flag STATE_CTP_ERROR.

Command GCTP

```
result_t get_ctp_settings (device_t id, ctp_settings_t* ctp_settings)
```

Command code (CMD): "gctp" or 0x70746367.

Request: (4 bytes)

INT32U	CMD	Command
--------	-----	---------

Answer: (18 bytes)

INT32U	CMD	Command (answer)
INT8U	CTPMinError	Minimum contrast steps from step motor encoder position, with set STATE_CTP_ERROR flag. Measured in steps step motor.
INT8U	CTPFlags	Flags.
		0x01 - CTP_ENABLED (Position control is enabled, if flag set.)
		0x02 - CTP_BASE (Position control is based on revolution sensor, if this flag is set; otherwise it is based on encoder.)
		0x04 - CTP_ALARM_ON_ERROR (Set ALARM on mismatch, if flag set.)
		0x08 - REV_SENS_INV (Sensor is active when it 0 and invert makes active level 1. That is, if you do not invert, it is normal logic - 0 is the activation.)
		0x10 - CTP_ERROR_CORRECTION (Correct errors which appear when slippage if the flag is set. It works only with the encoder. Incompatible with flag CTP_ALARM_ON_ERROR.)
INT8U	Reserved [10]	Reserved (10 bytes)
INT16U	CRC	Checksum

Description:

Read settings of control position (is only used with stepper motor). When controlling the step motor with encoder (CTP_BASE 0) it is possible to detect the loss of steps. The controller knows the number of steps per revolution (GENG :: StepsPerRev) and the encoder resolution (GFBS :: IPT). When the control (flag CTP_ENABLED), the controller stores the current position in the footsteps of SM and the current position of the encoder. Further, at each step of the position encoder is converted into steps and if the difference is greater CTPMinError, a flag STATE_CTP_ERROR. When controlling the step motor with speed sensor (CTP_BASE 1), the position is controlled by him. The active edge of input clock controller stores the current value of steps. Further, at each turn checks how many steps shifted. When a mismatch CTPMinError a flag STATE_CTP_ERROR.

Command SURT

```
result_t set_uart_settings (device_t id, const uart_settings_t* uart_settings)
```

Command code (CMD): "surt" or 0x74727573.

Request: (16 bytes)

INT32U	CMD	Command
INT32U	Speed	UART speed
INT16U	UARTSetupFlags	UART setup flags
		0x03 - UART_PARITY_BITS (Bits of the parity.)
		0x00 - UART_PARITY_BIT_EVEN (Parity bit 1, if even)
		0x01 - UART_PARITY_BIT_ODD (Parity bit 1, if odd)
		0x02 - UART_PARITY_BIT_SPACE (Parity bit always 0)
		0x03 - UART_PARITY_BIT_MARK (Parity bit always 1)
		0x04 - UART_PARITY_BIT_USE (None parity)
		0x08 - UART_STOP_BIT (If set - one stop bit, else two stop bit)
INT8U	Reserved [4]	Reserved (4 bytes)
INT16U	CRC	Checksum

Answer: (4 bytes)

INT32U	CMD	Command (answer)
--------	-----	------------------

Description:

Set UART settings. This function send structure with UART settings to controller's memory.

Command GURT

```
result_t get_uart_settings (device_t id, uart_settings_t* uart_settings)
```

Command code (CMD): "gurt" or 0x74727567.

Request: (4 bytes)

INT32U	CMD	Command
--------	-----	---------

Answer: (16 bytes)

INT32U	CMD	Command (answer)
INT32U	Speed	UART speed
INT16U	UARTSetupFlags	UART setup flags
		0x03 - UART_PARITY_BITS (Bits of the parity.)
		0x00 - UART_PARITY_BIT_EVEN (Parity bit 1, if even)
		0x01 - UART_PARITY_BIT_ODD (Parity bit 1, if odd)
		0x02 - UART_PARITY_BIT_SPACE (Parity bit always 0)
		0x03 - UART_PARITY_BIT_MARK (Parity bit always 1)
		0x04 - UART_PARITY_BIT_USE (None parity)
		0x08 - UART_STOP_BIT (If set - one stop bit, else two stop bit)
INT8U	Reserved [4]	Reserved (4 bytes)
INT16U	CRC	Checksum

Description:

Read UART settings. This function fill structure with UART settings.

Command SCAL

```
result_t set_calibration_settings (device_t id, const calibration_settings_t* calibration_settings)
```

Command code (CMD): "scal" or 0x6C616373.

Request: (118 bytes)

INT32U	CMD	Command
FLT32	CSS1_A	Scaling factor for the analogue measurements of the winding A current.
FLT32	CSS1_B	Shift factor for the analogue measurements of the winding A current.
FLT32	CSS2_A	Scaling factor for the analogue measurements of the winding B current.
FLT32	CSS2_B	Shift factor for the analogue measurements of the winding B current.
FLT32	FullCurrent_A	Scaling factor for the analogue measurements of the full current.
FLT32	FullCurrent_B	Shift factor for the analogue measurements of the full current.
INT8U	Reserved [88]	Reserved (88 bytes)
INT16U	CRC	Checksum

Answer: (4 bytes)

INT32U	CMD	Command (answer)
--------	-----	------------------

Description:

Set calibration settings. This function send structure with calibration settings to controller's memory.

Command GCAL

```
result_t get_calibration_settings (device_t id, calibration_settings_t* calibration_settings)
```

Command code (CMD): "gcal" or 0x6C616367.

Request: (4 bytes)

INT32U	CMD	Command
--------	-----	---------

Answer: (118 bytes)

INT32U	CMD	Command (answer)
FLT32	CSS1_A	Scaling factor for the analogue measurements of the winding A current.
FLT32	CSS1_B	Shift factor for the analogue measurements of the winding A current.
FLT32	CSS2_A	Scaling factor for the analogue measurements of the winding B current.
FLT32	CSS2_B	Shift factor for the analogue measurements of the winding B current.
FLT32	FullCurrent_A	Scaling factor for the analogue measurements of the full current.
FLT32	FullCurrent_B	Shift factor for the analogue measurements of the full current.
INT8U	Reserved [88]	Reserved (88 bytes)
INT16U	CRC	Checksum

Description:

Read calibration settings. This function fill structure with calibration settings.

Command SNMF

```
result_t set_controller_name (device_t id, const controller_name_t* controller_name)
```

Command code (CMD): "snmf" or 0x666D6E73.

Request: (30 bytes)

INT32U	CMD	Command
CHAR	ControllerName [16]	User conroller name. Can be set by user for his/her convinience. Max string length: 16 chars.
INT8U	CtrlFlags	Internal controller settings. 0x01 - EEPROM_PRECEDENCE (If the flag is set settings from external EEPROM override controller settings.)
INT8U	Reserved [7]	Reserved (7 bytes)
INT16U	CRC	Checksum

Answer: (4 bytes)

INT32U	CMD	Command (answer)
--------	-----	------------------

Description:

Write user controller name and flags of setting from FRAM.

Command GNMF

```
result_t get_controller_name (device_t id, controller_name_t* controller_name)
```

Command code (CMD): "gnmf" or 0x666D6E67.

Request: (4 bytes)

INT32U	CMD	Command
--------	-----	---------

Answer: (30 bytes)

INT32U	CMD	Command (answer)
CHAR	ControllerName [16]	User conroller name. Can be set by user for his/her convinience. Max string length: 16 chars.
INT8U	CtrlFlags	Internal controller settings. 0x01 - EEPROM_PRECEDENCE (If the flag is set settings from external EEPROM override controller settings.)
INT8U	Reserved [7]	Reserved (7 bytes)
INT16U	CRC	Checksum

Description:

Read user controller name and flags of setting from FRAM.

Command SNVM

```
result_t set_nonvolatile_memory (device_t id, const nonvolatile_memory_t* nonvolatile_memory)
```

Command code (CMD): "snvm" or 0x6D766E73.

Request: (36 bytes)

INT32U	CMD	Command
INT32U	UserData [7]	User data. Can be set by user for his/her convinience. Each element of the array stores only 32 bits of user data. This is important on systems where an int type contains more than 4 bytes. For example that all amd64 systems.
INT8U	Reserved [2]	Reserved (2 bytes)
INT16U	CRC	Checksum

Answer: (4 bytes)

INT32U	CMD	Command (answer)
--------	-----	------------------

Description:

Write userdata into FRAM.

Command GNVN

```
result_t get_nonvolatile_memory (device_t id, nonvolatile_memory_t* nonvolatile_memory)
```

Command code (CMD): "gnvm" or 0x6D766E67.

Request: (4 bytes)

INT32U	CMD	Command
--------	-----	---------

Answer: (36 bytes)

INT32U	CMD	Command (answer)
INT32U	UserData [7]	User data. Can be set by user for his/her convinience. Each element of the array stores only 32 bits of user data. This is important on systems where an int type contains more than 4 bytes. For example that all amd64 systems.
INT8U	Reserved [2]	Reserved (2 bytes)
INT16U	CRC	Checksum

Description:

Read userdata from FRAM.

Group of commands movement control

Command STOP

```
result_t command_stop (device_t id)
```

Command code (CMD): "stop" or 0x706F7473.

Request: (4 bytes)

INT32U	CMD	Command
--------	-----	---------

Answer: (4 bytes)

INT32U	CMD	Command (answer)
--------	-----	------------------

Description:

Immediately stop the engine, the transition to the STOP, mode key BREAK (winding short-circuited), the regime "retention" is deactivated for DC motors, keeping current in the windings for stepper motors (with Power management settings).

Command ASIA

```
result_t command_add_sync_in_action (device_t id, const command_add_sync_in_action_t* the_command_add_sync_in_action)
```

Command code (CMD): "asia" or 0x61697361.

Request: (22 bytes)

INT32U	CMD	Command
INT32S	Position	Desired position or shift (whole steps)
INT16S	uPosition	The fractional part of a position or shift in microsteps. Is only used with stepper motor. Range: -255..255.
INT32U	Time	Time for which you want to achieve the desired position in microseconds.
INT8U	Reserved [6]	Reserved (6 bytes)
INT16U	CRC	Checksum

Answer: (4 bytes)

INT32U	CMD	Command (answer)
--------	-----	------------------

Description:

This command adds one element of the FIFO commands that are executed when input clock pulse. Each pulse synchronization or perform that action, which is described in SSNI, if the buffer is empty, or the oldest loaded into the buffer action to temporarily replace the speed and coordinate in SSNI. In the latter case this action is erased from the buffer. The number of remaining empty buffer elements can be found in the structure of GETS.

Command PWOFF

```
result_t command_power_off (device_t id)
```

Command code (CMD): "pwof" or 0x666F7770.

Request: (4 bytes)

INT32U	CMD	Command
--------	-----	---------

Answer: (4 bytes)

INT32U	CMD	Command (answer)
--------	-----	------------------

Description:

Immediately power off motor regardless its state. Shouldn't be used during motion as the motor could be power on again automatically to continue movement. The command is designed for manual motor power off. When automatic power off after stop is required, use power management system.

Command MOVE

```
result_t command_move (device_t id, int Position, int uPosition)
```

Command code (CMD): "move" or 0x65766F6D.

Request: (18 bytes)

INT32U	CMD	Command
INT32S	Position	Desired position (whole steps).
INT16S	uPosition	The fractional part of a position in microsteps. Is only used with stepper motor. Range: -255..255.
INT8U	Reserved [6]	Reserved (6 bytes)
INT16U	CRC	Checksum

Answer: (4 bytes)

INT32U	CMD	Command (answer)
--------	-----	------------------

Description:

Upon receiving the command "move" the engine starts to move with pre-set parameters (speed, acceleration, retention), to the point specified to the Position, uPosition. For stepper motor uPosition sets the microstep, for DC motor this field is not used.

Command MOVR

```
result_t command_movr (device_t id, int DeltaPosition, int uDeltaPosition)
```

Command code (CMD): "movr" or 0x72766F6D.

Request: (18 bytes)

INT32U	CMD	Command
INT32S	DeltaPosition	Shift (delta) of position
INT16S	uDeltaPosition	Fractional part of the shift in micro steps is only used with stepper motor. Range: -255..255.
INT8U	Reserved [6]	Reserved (6 bytes)
INT16U	CRC	Checksum

Answer: (4 bytes)

INT32U	CMD	Command (answer)
--------	-----	------------------

Description:

Upon receiving the command "movr" engine starts to move with pre-set parameters (speed, acceleration, hold), left or right (depending on the sign of DeltaPosition) by the number of pulses specified in the fields DeltaPosition, uDeltaPosition. For stepper motor uDeltaPosition sets the microstep, for DC motor this field is not used.

Command HOME

```
result_t command_home (device_t id)
```

Command code (CMD): "home" or 0x656D6F68.

Request: (4 bytes)

INT32U	CMD	Command
--------	-----	---------

Answer: (4 bytes)

INT32U	CMD	Command (answer)
--------	-----	------------------

Description:

The positive direction is to the right. A value of zero reverses the direction of the flag, the set speed. Restriction imposed by the trailer, act the same, except that the limit switch contact does not stop. Limit the maximum speed, acceleration and deceleration function. 1) moves the motor according to the speed FastHome, uFastHome and flag HOME_DIR_FAST until limit switch, if the flag is set HOME_STOP_ENDS, until the signal from the input synchronization if the flag HOME_STOP_SYNC (as accurately as possible is important to catch the moment of operation limit switch) or until the signal is received from the speed sensor, if the flag HOME_STOP_REV_SN 2) then moves according to the speed SlowHome, uSlowHome and flag HOME_DIR_SLOW until signal from the clock input, if the flag HOME_MV_SEC. If the flag HOME_MV_SEC reset skip this paragraph. 3) then move the motor according to the speed FastHome, uFastHome and flag HOME_DIR_SLOW a distance HomeDelta, uHomeDelta. description of flags and variable see in description for commands GHOM/SHOM

Command LEFT

```
result_t command_left (device_t id)
```

Command code (CMD): "left" or 0x7466656C.

Request: (4 bytes)

INT32U	CMD	Command
--------	-----	---------

Answer: (4 bytes)

INT32U	CMD	Command (answer)
--------	-----	------------------

Description:

Start continuous moving to the left.

Command RIGHT

```
result_t command_right (device_t id)
```

Command code (CMD): "right" or 0x74676972.

Request: (4 bytes)

INT32U	CMD	Command
--------	-----	---------

Answer: (4 bytes)

INT32U	CMD	Command (answer)
--------	-----	------------------

Description:

Start continuous moving to the right.

Command LOFT

```
result_t command_loft (device_t id)
```

Command code (CMD): "loft" or 0x74666F6C.

Request: (4 bytes)

INT32U	CMD	Command
--------	-----	---------

Answer: (4 bytes)

INT32U	CMD	Command (answer)
--------	-----	------------------

Description:

Upon receiving the command "loft" the engine is shifted from the current point to a distance GENG :: Antiplay, then move to the same point.

Command SSTP

```
result_t command_sstp (device_t id)
```

Command code (CMD): "sstp" or 0x70747373.

Request: (4 bytes)

INT32U	CMD	Command
--------	-----	---------

Answer: (4 bytes)

INT32U	CMD	Command (answer)
--------	-----	------------------

Description:

Soft stop engine. The motor stops with deceleration speed.

Group of commands set the current position**Command GPOS**

```
result_t get_position (device_t id, get_position_t* the_get_position)
```

Command code (CMD): "gpos" or 0x736F7067.

Request: (4 bytes)

INT32U	CMD	Command
--------	-----	---------

Answer: (26 bytes)

INT32U	CMD	Command (answer)
INT32S	Position	The position of the whole steps in the engine
INT16S	uPosition	Microstep position is only used with stepper motors
INT64S	EncPosition	Encoder position.
INT8U	Reserved [6]	Reserved (6 bytes)
INT16U	CRC	Checksum

Description:

Reads the value position in steps and micro for stepper motor and encoder steps all engines.

Command SPOS

```
result_t set_position (device_t id, const set_position_t* the_set_position)
```

Command code (CMD): "spos" or 0x736F7073.

Request: (26 bytes)

INT32U	CMD	Command
INT32S	Position	The position of the whole steps in the engine
INT16S	uPosition	Microstep position is only used with stepper motors
INT64S	EncPosition	Encoder position.
INT8U	PosFlags	Flags
		0x01 - SETPOS_IGNORE_POSITION (Will not reload position in steps/microsteps if this flag is set.)
		0x02 - SETPOS_IGNORE_ENCODER (Will not reload encoder state if this flag is set.)
INT8U	Reserved [5]	Reserved (5 bytes)
INT16U	CRC	Checksum

Answer: (4 bytes)

INT32U	CMD	Command (answer)
--------	-----	------------------

Description:

Sets any position value in steps and micro for stepper motor and encoder steps of all engines. It means, that changing main indicator of position.

Command ZERO

```
result_t command_zero (device_t id)
```

Command code (CMD): "zero" or 0x6F72657A.

Request: (4 bytes)

INT32U	CMD	Command
--------	-----	---------

Answer: (4 bytes)

INT32U	CMD	Command (answer)
--------	-----	------------------

Description:

Sets the current position and the position in which the traffic moves by the move command and movr zero for all cases, except for movement to the target position. In the latter case, set the zero current position and the target position counted so that the absolute position of the destination is the same. That is, if we were at 400 and moved to 500, then the command Zero makes the current position of 0, and the position of the destination - 100. Does not change the mode of movement that is if the motion is carried, it continues, and if the engine is in the "hold", the type of retention remains.

Group of commands to save and load settings

Command SAVE

```
result_t command_save_settings (device_t id)
```

Command code (CMD): "save" or 0x65766173.

Request: (4 bytes)

INT32U	CMD	Command
--------	-----	---------

Answer: (4 bytes)

INT32U	CMD	Command (answer)
--------	-----	------------------

Description:

Save all settings from controller's RAM to controller's flash memory, replacing previous data in controller's flash memory.

Command READ

```
result_t command_read_settings (device_t id)
```

Command code (CMD): "read" or 0x64616572.

Request: (4 bytes)

INT32U	CMD	Command
--------	-----	---------

Answer: (4 bytes)

INT32U	CMD	Command (answer)
--------	-----	------------------

Description:

Read all settings from controller's flash memory to controller's RAM, replacing previous data in controller's RAM.

Command SARS

```
result_t command_save_robust_settings (device_t id)
```

Command code (CMD): "sars" or 0x73726173.

Request: (4 bytes)

INT32U	CMD	Command
--------	-----	---------

Answer: (4 bytes)

INT32U	CMD	Command (answer)
--------	-----	------------------

Description:

Save important settings (calibration coefficients and etc.) from controller's RAM to controller's flash memory, replacing previous data in controller's flash memory.

Command RERS

```
result_t command_read_robust_settings (device_t id)
```

Command code (CMD): "rers" or 0x73726572.

Request: (4 bytes)

INT32U	CMD	Command
--------	-----	---------

Answer: (4 bytes)

INT32U	CMD	Command (answer)
--------	-----	------------------

Description:

Read important settings (calibration coefficients and etc.) from controller's flash memory to controller's RAM, replacing previous data in controller's RAM.

Command EESV

```
result_t command_eesave_settings (device_t id)
```

Command code (CMD): "eesv" or 0x76736565.

Request: (4 bytes)

INT32U	CMD	Command
--------	-----	---------

Answer: (4 bytes)

INT32U	CMD	Command (answer)
--------	-----	------------------

Description:

Save settings from controller's RAM to stage's EEPROM memory, which spontaneity connected to stage and it isn't change without it mechanical reconstruction. Can be used by manufacturer only.

Command EERD

```
result_t command_eeread_settings (device_t id)
```

Command code (CMD): "eerd" or 0x64726565.

Request: (4 bytes)

INT32U	CMD	Command
--------	-----	---------

Answer: (4 bytes)

INT32U	CMD	Command (answer)
--------	-----	------------------

Description:

Read settings from controller's RAM to stage's EEPROM memory, which spontaneity connected to stage and it isn't change without it mechanical reconstruction.

Group of commands get the status of the controller**Command GETS**

```
result_t get_status (device_t id, status_t* status)
```

Command code (CMD): "gets" or 0x73746567.

Request: (4 bytes)

INT32U	CMD	Command
--------	-----	---------

Answer: (54 bytes)

INT32U	CMD	Command (answer)
INT8U	MoveSts	Move state.
		0x01 - MOVE_STATE_MOVING (This flag indicates that controller is trying to move the motor. Don't use this flag for waiting of completion of the movement command. Use MVCMD_RUNNING flag from the MvCmdSts field instead.)
		0x02 - MOVE_STATE_TARGET_SPEED (Target speed is reached, if flag set.)
		0x04 - MOVE_STATE_ANTIPLAY (Motor is playing compensation, if flag set.)
INT8U	MvCmdSts	Move command state.
		0x3F - MVCMD_NAME_BITS (Move command bit mask.)
		0x00 - MVCMD_UKNWN (Unknown command.)
		0x01 - MVCMD_MOVE (Command move.)
		0x02 - MVCMD_MOVR (Command movr.)
		0x03 - MVCMD_LEFT (Command left.)
		0x04 - MVCMD_RIGHT (Command rigt.)
		0x05 - MVCMD_STOP (Command stop.)
		0x06 - MVCMD_HOME (Command home.)
		0x07 - MVCMD_LOFT (Command loft.)
		0x08 - MVCMD_SSTP (Command soft stop.)
		0x40 - MVCMD_ERROR (Finish state (1 - move command have finished with an error, 0 - move command have finished correctly). This flags is actual when MVCMD_RUNNING signals movement finish.)
		0x80 - MVCMD_RUNNING (Move command state (0 - move command have finished, 1 - move command is being executed).)
INT8U	PWRSts	Power state of the stepper motor (used only with stepper motor).
		0x00 - PWR_STATE_UNKNOWN (Unknown state, should never happen.)
		0x01 - PWR_STATE_OFF (Motor windings are disconnected from the driver.)
		0x03 - PWR_STATE_NORM (Motor windings are powered by nominal current.)
		0x04 - PWR_STATE_REDUCT (Motor windings are powered by reduced current to lower power consumption.)
		0x05 - PWR_STATE_MAX (Motor windings are powered by maximum current driver can provide at this voltage.)
INT8U	EncSts	Encoder state.
		0x00 - ENC_STATE_ABSENT (Encoder is absent.)
		0x01 - ENC_STATE_UNKNOWN (Encoder state is unknown.)
		0x02 - ENC_STATE_MALFUNC (Encoder is connected and malfunctioning.)
		0x03 - ENC_STATE_REVERS (Encoder is connected and operational but counts in other direction.)
		0x04 - ENC_STATE_OK (Encoder is connected and working properly.)
INT8U	WindSts	Windings state.

		0x00 - WIND_A_STATE_ABSENT (Winding A is disconnected.)
		0x01 - WIND_A_STATE_UNKNOWN (Winding A state is unknown.)
		0x02 - WIND_A_STATE_MALFUNC (Winding A is short-circuited.)
		0x03 - WIND_A_STATE_OK (Winding A is connected and working properly.)
		0x00 - WIND_B_STATE_ABSENT (Winding B is disconnected.)
		0x10 - WIND_B_STATE_UNKNOWN (Winding B state is unknown.)
		0x20 - WIND_B_STATE_MALFUNC (Winding B is short-circuited.)
		0x30 - WIND_B_STATE_OK (Winding B is connected and working properly.)
INT32S	CurPosition	Current position.
INT16S	uCurPosition	Step motor shaft position in 1/256 microsteps. Used only with stepper motor.
INT64S	EncPosition	Current encoder position.
INT32S	CurSpeed	Motor shaft speed.
INT16S	uCurSpeed	Part of motor shaft speed in 1/256 microsteps. Used only with stepper motor.
INT16S	Ipwr	Engine current.
INT16S	Upwr	Power supply voltage, tens of mV.
INT16S	Iusb	USB current consumption.
INT16S	Uusb	USB voltage, tens of mV.
INT16S	CurT	Temperature in tenths of degrees C.
INT32U	Flags	Set of flags specify motor shaft movement algorithm and list of limitations.
		0x00003F - STATE_CONTR (Flags of controller states.)
		0x000001 - STATE_ERRC (Command error encountered.)
		0x000002 - STATE_ERRD (Data integrity error encountered.)
		0x000004 - STATE_ERRV (Value error encountered.)
		0x000010 - STATE_EEPROM_CONNECTED (EEPROM with settings is connected.)
		0x000020 - STATE_IS_HOMED (Calibration performed)
		0x73FFC0 - STATE_SECUR (Flags of security.)
		0x000040 - STATE_ALARM (Controller is in alarm state indicating that something dangerous had happened. Most commands are ignored in this state. To reset the flag a STOP command must be issued.)
		0x000080 - STATE_CTP_ERROR (Control position error(is only used with stepper motor).)
		0x000100 - STATE_POWER_OVERHEAT (Power driver overheat.)
		0x000200 - STATE_CONTROLLER_OVERHEAT (Controller overheat.)
		0x000400 - STATE_OVERLOAD_POWER_VOLTAGE (Power voltage exceeds safe limit.)
		0x000800 - STATE_OVERLOAD_POWER_CURRENT (Power current exceeds safe limit.)
		0x001000 - STATE_OVERLOAD_USB_VOLTAGE (USB voltage exceeds safe limit.)
		0x002000 - STATE_LOW_USB_VOLTAGE (USB voltage is insufficient for normal operation.)
		0x004000 - STATE_OVERLOAD_USB_CURRENT (USB current exceeds safe limit.)
		0x008000 - STATE_BORDERS_SWAP_MISSET (Engine stuck at the wrong edge.)
		0x010000 - STATE_LOW_POWER_VOLTAGE (Power voltage is lower than Low Voltage Protection limit)
		0x020000 - STATE_H_BRIDGE_FAULT (Signal from the driver that fault happened)
		0x0C0000 - STATE_CURRENT_MOTOR_BITS (Bits indicating the current operating motor on boards with multiple outputs for engine mounting.)
		0x000000 - STATE_CURRENT_MOTOR0 (Motor 0.)
		0x040000 - STATE_CURRENT_MOTOR1 (Motor 1.)
		0x080000 - STATE_CURRENT_MOTOR2 (Motor 2.)
		0x0C0000 - STATE_CURRENT_MOTOR3 (Motor 3.)
		0x100000 - STATE_WINDING_RES_MISMATCH (The difference between winding resistances is too large)
		0x200000 - STATE_ENCODER_FAULT (Signal from the encoder that fault happened)
		0x400000 - STATE_MOTOR_CURRENT_LIMIT (Current limit exceeded)
INT32U	GPIOFlags	Set of flags of gpio states

		0xFFFF - STATE_DIG_SIGNAL (Flags of digital signals.)
		0x0001 - STATE_RIGHT_EDGE (Engine stuck at the right edge.)
		0x0002 - STATE_LEFT_EDGE (Engine stuck at the left edge.)
		0x0004 - STATE_BUTTON_RIGHT (Button "right" state (1 if pressed).)
		0x0008 - STATE_BUTTON_LEFT (Button "left" state (1 if pressed).)
		0x0010 - STATE_GPIO_PINOUT (External GPIO works as Out, if flag set; otherwise works as In.)
		0x0020 - STATE_GPIO_LEVEL (State of external GPIO pin.)
		0x0040 - STATE_HALL_A (State of Hall_a pin.)
		0x0080 - STATE_HALL_B (State of Hall_b pin.)
		0x0100 - STATE_HALL_C (State of Hall_c pin.)
		0x0200 - STATE_BRAKE (State of Brake pin.)
		0x0400 - STATE_REV_SENSOR (State of Revolution sensor pin.)
		0x0800 - STATE_SYNC_INPUT (State of Sync input pin.)
		0x1000 - STATE_SYNC_OUTPUT (State of Sync output pin.)
		0x2000 - STATE_ENC_A (State of encoder A pin.)
		0x4000 - STATE_ENC_B (State of encoder B pin.)
INT8U	CmdBufFreeSpace	This field shows the amount of free cells buffer synchronization chain.
INT8U	Reserved [4]	Reserved (4 bytes)
INT16U	CRC	Checksum

Description:

Return device state. Useful function that fills structure with snapshot of controller state, including speed, position and boolean flags.

Command STMS

```
result_t command_start_measurements (device_t id)
```

Command code (CMD): "stms" or 0x736D7473.

Request: (4 bytes)

INT32U	CMD	Command
--------	-----	---------

Answer: (4 bytes)

INT32U	CMD	Command (answer)
--------	-----	------------------

Description:

Start measurements and buffering of speed, following error.

Command GETM

```
result_t get_measurements (device_t id, measurements_t* measurements)
```

Command code (CMD): "getm" or 0x6D746567.

Request: (4 bytes)

INT32U	CMD	Command
--------	-----	---------

Answer: (216 bytes)

INT32U	CMD	Command (answer)
INT32S	Speed [25]	Current speed.
INT32S	Error [25]	Current error.
INT32U	Length	Length of actual data in buffer.
INT8U	Reserved [6]	Reserved (6 bytes)
INT16U	CRC	Checksum

Description:

A command to read the data buffer to build a speed graph and a sequence error. Filling the buffer starts with the command "start_measurements". The buffer holds 25 points, the points are taken with a period of 1 ms. To create a robust system, read data every 20 ms, if the buffer is completely full, then it is recommended to repeat the readings every 5 ms until the buffer again becomes filled with 20 points.

Command GETC

```
result_t get_chart_data (device_t id, chart_data_t* chart_data)
```

Command code (CMD): "getc" or 0x63746567.

Request: (4 bytes)

INT32U	CMD	Command
--------	-----	---------

Answer: (38 bytes)

INT32U	CMD	Command (answer)
INT16S	WindingVoltageA	In the case step motor, the voltage across the winding A; in the case of a brushless, the voltage on the first coil, in the case of the only DC.
INT16S	WindingVoltageB	In the case step motor, the voltage across the winding B; in case of a brushless, the voltage on the second winding, and in the case of DC is not used.
INT16S	WindingVoltageC	In the case of a brushless, the voltage on the third winding, in the case step motor and DC is not used.
INT16S	WindingCurrentA	In the case step motor, the current in the coil A; brushless if the current in the first coil, and in the case of a single DC.
INT16S	WindingCurrentB	In the case step motor, the current in the coil B; brushless if the current in the second coil, and in the case of DC is not used.
INT16S	WindingCurrentC	In the case of a brushless, the current in the third winding, in the case step motor and DC is not used.
INT16U	Pot	Analog input value in ten-thousandths. Range: 0..10000
INT16U	Joy	The joystick position in the ten-thousandths. Range: 0..10000
INT16S	DutyCycle	Duty cycle of PWM.
INT8U	Reserved [14]	Reserved (14 bytes)
INT16U	CRC	Checksum

Description:

Return device electrical parameters, useful for charts. Useful function that fill structure with snapshot of controller voltages and currents.

Command GETI

```
result_t get_device_information (device_t id, device_information_t* device_information)
```

Command code (CMD): "geti" or 0x69746567.

Request: (4 bytes)

INT32U	CMD	Command
--------	-----	---------

Answer: (36 bytes)

INT32U	CMD	Command (answer)
CHAR	Manufacturer [4]	Manufacturer
CHAR	ManufacturerId [2]	Manufacturer id
CHAR	ProductDescription [8]	Product description
INT8U	Major	The major number of the hardware version.
INT8U	Minor	Minor number of the hardware version.
INT16U	Release	Number of edits this release of hardware.
INT8U	Reserved [12]	Reserved (12 bytes)
INT16U	CRC	Checksum

Description:

Return device information. It's available from the firmware and bootloader.

Command GSER

```
result_t get_serial_number (device_t id, unsigned int* SerialNumber)
```

Command code (CMD): "gser" or 0x72657367.

Request: (4 bytes)

INT32U	CMD	Command
--------	-----	---------

Answer: (10 bytes)

INT32U	CMD	Command (answer)
INT32U	SerialNumber	Board serial number.
INT16U	CRC	Checksum

Description:

Read device serial number.

Group of commands to work with the controller firmware**Command GFVV**

```
result_t get_firmware_version (device_t id, unsigned int* Major, unsigned int* Minor, unsigned int* Release )
```

Command code (CMD): "gfvv" or 0x76776667.

Request: (4 bytes)

INT32U	CMD	Command
--------	-----	---------

Answer: (10 bytes)

INT32U	CMD	Command (answer)
INT8U	Major	Firmware major version number
INT8U	Minor	Firmware minor version number
INT16U	Release	Firmware release version number
INT16U	CRC	Checksum

Description:

Read controller's firmware version.

Command UPDF

```
result_t service_command_updf (device_t id)
```

Command code (CMD): "updf" or 0x66647075.

Request: (4 bytes)

INT32U	CMD	Command
--------	-----	---------

Answer: (4 bytes)

INT32U	CMD	Command (answer)
--------	-----	------------------

Description:

Command puts the controller to update the firmware. After receiving this command, the firmware board sets a flag (for loader), sends echo reply and restarts the controller.

Service commands**Command SSER**

```
result_t set_serial_number (device_t id, const serial_number_t* serial_number)
```

Command code (CMD): "sser" or 0x72657373.

Request: (50 bytes)

INT32U	CMD	Command
INT32U	SN	New board serial number.
INT8U	Key [32]	Protection key (256 bit).
INT8U	Major	The major number of the hardware version.
INT8U	Minor	Minor number of the hardware version.
INT16U	Release	Number of edits this release of hardware.
INT8U	Reserved [4]	Reserved (4 bytes)
INT16U	CRC	Checksum

Answer: (4 bytes)

INT32U	CMD	Command (answer)
--------	-----	------------------

Description:

Write device serial number and hardware version to controller's flash memory. Along with the new serial number and hardware version a "Key" is transmitted. The SN and hardware version are changed and saved when keys match. Can be used by manufacturer only.

Command RDAN

```
result_t get_analog_data (device_t id, analog_data_t* analog_data)
```

Command code (CMD): "rdan" or 0x6E616472.

Request: (4 bytes)

INT32U	CMD	Command
--------	-----	---------

Answer: (76 bytes)

INT32U	CMD	Command (answer)
INT16U	A1Voltage_ADC	"Voltage on pin 1 winding A" raw data from ADC.
INT16U	A2Voltage_ADC	"Voltage on pin 2 winding A" raw data from ADC.
INT16U	B1Voltage_ADC	"Voltage on pin 1 winding B" raw data from ADC.
INT16U	B2Voltage_ADC	"Voltage on pin 2 winding B" raw data from ADC.
INT16U	SupVoltage_ADC	"Voltage on the top of MOSFET full bridge" raw data from ADC.
INT16U	ACurrent_ADC	"Winding A current" raw data from ADC.
INT16U	BCurrent_ADC	"Winding B current" raw data from ADC.
INT16U	FullCurrent_ADC	"Full current" raw data from ADC.
INT16U	Temp_ADC	Voltage from temperature sensor, raw data from ADC.
INT16U	Joy_ADC	Joystick raw data from ADC.
INT16U	Pot_ADC	Voltage on analog input, raw data from ADC
INT16U	L5_ADC	USB supply voltage after the current sense resistor, from ADC.
INT16U	H5_ADC	Power supply USB from ADC
INT16S	A1Voltage	"Voltage on pin 1 winding A" calibrated data.
INT16S	A2Voltage	"Voltage on pin 2 winding A" calibrated data.
INT16S	B1Voltage	"Voltage on pin 1 winding B" calibrated data.
INT16S	B2Voltage	"Voltage on pin 2 winding B" calibrated data.
INT16S	SupVoltage	"Voltage on the top of MOSFET full bridge" calibrated data.
INT16S	ACurrent	"Winding A current" calibrated data.
INT16S	BCurrent	"Winding B current" calibrated data.
INT16S	FullCurrent	"Full current" calibrated data.
INT16S	Temp	Temperature, calibrated data.
INT16S	Joy	Joystick, calibrated data. Range: 0..10000
INT16S	Pot	Analog input, calibrated data. Range: 0..10000
INT16S	L5	USB supply voltage after the current sense resistor.
INT16S	H5	Power supply USB
INT16U	deprecated	
INT32S	R	Motor winding resistance in mOhms(is only used with stepper motor).
INT32S	L	Motor winding pseudo inductance in uHn(is only used with stepper motor).
INT8U	Reserved [8]	Reserved (8 bytes)
INT16U	CRC	Checksum

Description:

Read analog data structure that contains raw analog data from ADC embedded on board. This function used for device testing and deep recalibration by manufacturer only.

Command DBGR

```
result_t get_debug_read (device_t id, debug_read_t* debug_read)
```

Command code (CMD): "dbgr" or 0x72676264.

Request: (4 bytes)

INT32U	CMD	Command
--------	-----	---------

Answer: (142 bytes)

INT32U	CMD	Command (answer)
INT8U	DebugData [128]	Arbitrary debug data.
INT8U	Reserved [8]	Reserved (8 bytes)
INT16U	CRC	Checksum

Description:

Read data from firmware for debug purpose. Its use depends on context, firmware version and previous history.

Command DBGW

```
result_t set_debug_write (device_t id, const debug_write_t* debug_write)
```

Command code (CMD): "dbgw" or 0x77676264.

Request: (142 bytes)

INT32U	CMD	Command
INT8U	DebugData [128]	Arbitrary debug data.
INT8U	Reserved [8]	Reserved (8 bytes)
INT16U	CRC	Checksum

Answer: (4 bytes)

INT32U	CMD	Command (answer)
--------	-----	------------------

Description:

Write data to firmware for debug purpose.

Group of commands to work with EEPROM**Command SNME**

```
result_t set_stage_name (device_t id, const stage_name_t* stage_name)
```

Command code (CMD): "snme" or 0x656D6E73.

Request: (30 bytes)

INT32U	CMD	Command
CHAR	PositionerName [16]	User positioner name. Can be set by user for his/her convinience. Max string length: 16 chars.
INT8U	Reserved [8]	Reserved (8 bytes)
INT16U	CRC	Checksum

Answer: (4 bytes)

INT32U	CMD	Command (answer)
--------	-----	------------------

Description:

Write user stage name from EEPROM.

Command GNME

```
result_t get_stage_name (device_t id, stage_name_t* stage_name)
```

Command code (CMD): "gnme" or 0x656D6E67.

Request: (4 bytes)

INT32U	CMD	Command
--------	-----	---------

Answer: (30 bytes)

INT32U	CMD	Command (answer)
CHAR	PositionerName [16]	User positioner name. Can be set by user for his/her convinience. Max string length: 16 chars.
INT8U	Reserved [8]	Reserved (8 bytes)
INT16U	CRC	Checksum

Description:

Read user stage name from EEPROM.

Command SSTI

```
result_t set_stage_information (device_t id, const stage_information_t* stage_information)
```

Command code (CMD): "ssti" or 0x69747373.

Request: (70 bytes)

INT32U	CMD	Command
CHAR	Manufacturer [16]	Manufacturer. Max string length: 16 chars.
CHAR	PartNumber [24]	Series and PartNumber. Max string length: 24 chars.
INT8U	Reserved [24]	Reserved (24 bytes)
INT16U	CRC	Checksum

Answer: (4 bytes)

INT32U	CMD	Command (answer)
--------	-----	------------------

Description:

Set stage information to EEPROM. Can be used by manufacturer only.

Command GSTI

```
result_t get_stage_information (device_t id, stage_information_t* stage_information)
```

Command code (CMD): "gsti" or 0x69747367.

Request: (4 bytes)

INT32U	CMD	Command
--------	-----	---------

Answer: (70 bytes)

INT32U	CMD	Command (answer)
CHAR	Manufacturer [16]	Manufacturer. Max string length: 16 chars.
CHAR	PartNumber [24]	Series and PartNumber. Max string length: 24 chars.
INT8U	Reserved [24]	Reserved (24 bytes)
INT16U	CRC	Checksum

Description:

Read stage information from EEPROM.

Command SSTS

```
result_t set_stage_settings (device_t id, const stage_settings_t* stage_settings)
```

Command code (CMD): "ssts" or 0x73747373.

Request: (70 bytes)

INT32U	CMD	Command
FLT32	LeadScrewPitch	Lead screw pitch (mm). Data type: float.
CHAR	Units [8]	Units for MaxSpeed and TravelRange fields of the structure (steps, degrees, mm, ...). Max string length: 8 chars.
FLT32	MaxSpeed	Max speed (Units/c). Data type: float.
FLT32	TravelRange	Travel range (Units). Data type: float.
FLT32	SupplyVoltageMin	Supply voltage minimum (V). Data type: float.
FLT32	SupplyVoltageMax	Supply voltage maximum (V). Data type: float.
FLT32	MaxCurrentConsumption	Max current consumption (A). Data type: float.
FLT32	HorizontalLoadCapacity	Horizontal load capacity (kg). Data type: float.
FLT32	VerticalLoadCapacity	Vertical load capacity (kg). Data type: float.
INT8U	Reserved [24]	Reserved (24 bytes)
INT16U	CRC	Checksum

Answer: (4 bytes)

INT32U	CMD	Command (answer)
--------	-----	------------------

Description:

Set stage settings to EEPROM. Can be used by manufacturer only

Command GSTS

```
result_t get_stage_settings (device_t id, stage_settings_t* stage_settings)
```

Command code (CMD): "gsts" or 0x73747367.

Request: (4 bytes)

INT32U	CMD	Command
--------	-----	---------

Answer: (70 bytes)

INT32U	CMD	Command (answer)
FLT32	LeadScrewPitch	Lead screw pitch (mm). Data type: float.
CHAR	Units [8]	Units for MaxSpeed and TravelRange fields of the structure (steps, degrees, mm, ...). Max string length: 8 chars.
FLT32	MaxSpeed	Max speed (Units/c). Data type: float.
FLT32	TravelRange	Travel range (Units). Data type: float.
FLT32	SupplyVoltageMin	Supply voltage minimum (V). Data type: float.
FLT32	SupplyVoltageMax	Supply voltage maximum (V). Data type: float.
FLT32	MaxCurrentConsumption	Max current consumption (A). Data type: float.
FLT32	HorizontalLoadCapacity	Horizontal load capacity (kg). Data type: float.
FLT32	VerticalLoadCapacity	Vertical load capacity (kg). Data type: float.
INT8U	Reserved [24]	Reserved (24 bytes)
INT16U	CRC	Checksum

Description:

Read stage settings from EEPROM.

Command SMTI

```
result_t set_motor_information (device_t id, const motor_information_t* motor_information)
```

Command code (CMD): "smti" or 0x69746D73.

Request: (70 bytes)

INT32U	CMD	Command
CHAR	Manufacturer [16]	Manufacturer. Max string length: 16 chars.
CHAR	PartNumber [24]	Series and PartNumber. Max string length: 24 chars.
INT8U	Reserved [24]	Reserved (24 bytes)
INT16U	CRC	Checksum

Answer: (4 bytes)

INT32U	CMD	Command (answer)
--------	-----	------------------

Description:

Set motor information to EEPROM. Can be used by manufacturer only.

Command GMTI

```
result_t get_motor_information (device_t id, motor_information_t* motor_information)
```

Command code (CMD): "gmti" or 0x69746D67.

Request: (4 bytes)

INT32U	CMD	Command
--------	-----	---------

Answer: (70 bytes)

INT32U	CMD	Command (answer)
CHAR	Manufacturer [16]	Manufacturer. Max string length: 16 chars.
CHAR	PartNumber [24]	Series and PartNumber. Max string length: 24 chars.
INT8U	Reserved [24]	Reserved (24 bytes)
INT16U	CRC	Checksum

Description:

Read motor information from EEPROM.

Command SMTS

```
result_t set_motor_settings (device_t id, const motor_settings_t* motor_settings)
```

Command code (CMD): "smts" or 0x73746D73.

Request: (112 bytes)

INT32U	CMD	Command
INT8U	MotorType	Motor type
		0x00 - MOTOR_TYPE_UNKNOWN (Unknown type of engine)
		0x01 - MOTOR_TYPE_STEP (Step engine)
		0x02 - MOTOR_TYPE_DC (DC engine)
		0x03 - MOTOR_TYPE_BLDC (BLDC engine)
INT8U	ReservedField	Reserved
INT16U	Poles	Number of pole pairs for DC or BLDC motors or number of steps per rotation for stepper motor.
INT16U	Phases	Number of phases for BLDC motors.
FLT32	NominalVoltage	Nominal voltage on winding (B). Data type: float
FLT32	NominalCurrent	Maximum direct current in winding for DC and BLDC engines, nominal current in windings for stepper motor (A). Data type: float.
FLT32	NominalSpeed	Nominal speed(rpm). Used for DC and BLDC engine. Data type: float.
FLT32	NominalTorque	Nominal torque(mN m). Used for DC and BLDC engine. Data type: float.
FLT32	NominalPower	Nominal power(W). Used for DC and BLDC engine. Data type: float.
FLT32	WindingResistance	Resistance of windings for DC engine, each of two windings for stepper motor or each of there windings for BLDC engine(Ohm). Data type: float
FLT32	WindingInductance	Inductance of windings for DC engine, each of two windings for stepper motor or each of there windings for BLDC engine(mH). Data type: float
FLT32	RotorInertia	Rotor inertia(g cm2). Data type: float
FLT32	StallTorque	Torque hold position for a stepper motor or torque at a motionless rotor for other types of engines (mN m). Data type: float.
FLT32	DetentTorque	Holding torque position with un-powered coils (mN m). Data type: float.
FLT32	TorqueConstant	Torque constant, which determines the aspect ratio of maximum moment of force from the rotor current flowing in the coil (mN m / A). Used mainly for DC motors. Data type: float.
FLT32	SpeedConstant	Velocity constant, which determines the value or amplitude of the induced voltage on the motion of DC or BLDC motor (rpm / V) or stepper motor (steps/s / V). Data type: float.
FLT32	SpeedTorqueGradient	Speed torque gradient (rpm / mN m). Data type: float.
FLT32	MechanicalTimeConstant	Mechanical time constant (ms). Data type: float.
FLT32	MaxSpeed	The maximum speed for stepper motors (steps/s) or DC and BLDC motors (rmp). Data type: float.
FLT32	MaxCurrent	The maximum current in the winding (A). Data type: float.
FLT32	MaxCurrentTime	Safe duration of overcurrent in the winding (ms). Data type: float.
FLT32	NoLoadCurrent	The current consumption in idle mode (A). Used for DC and BLDC motors. Data type: float.
FLT32	NoLoadSpeed	Idle speed (rpm). Used for DC and BLDC motors. Data type: float.
INT8U	Reserved [24]	Reserved (24 bytes)
INT16U	CRC	Checksum

Answer: (4 bytes)

INT32U	CMD	Command (answer)
--------	-----	------------------

Description:

Set motor settings to EEPROM. Can be used by manufacturer only.

Command GMTS

```
result_t get_motor_settings (device_t id, motor_settings_t* motor_settings)
```

Command code (CMD): "gmts" or 0x73746D67.

Request: (4 bytes)

INT32U	CMD	Command
--------	-----	---------

Answer: (112 bytes)

INT32U	CMD	Command (answer)
INT8U	MotorType	Motor type
		0x00 - MOTOR_TYPE_UNKNOWN (Unknown type of engine)
		0x01 - MOTOR_TYPE_STEP (Step engine)
		0x02 - MOTOR_TYPE_DC (DC engine)
		0x03 - MOTOR_TYPE_BLDC (BLDC engine)
INT8U	ReservedField	Reserved
INT16U	Poles	Number of pole pairs for DC or BLDC motors or number of steps per rotation for stepper motor.
INT16U	Phases	Number of phases for BLDC motors.
FLT32	NominalVoltage	Nominal voltage on winding (B). Data type: float
FLT32	NominalCurrent	Maximum direct current in winding for DC and BLDC engines, nominal current in windings for stepper motor (A). Data type: float.
FLT32	NominalSpeed	Nominal speed(rpm). Used for DC and BLDC engine. Data type: float.
FLT32	NominalTorque	Nominal torque(mN m). Used for DC and BLDC engine. Data type: float.
FLT32	NominalPower	Nominal power(W). Used for DC and BLDC engine. Data type: float.
FLT32	WindingResistance	Resistance of windings for DC engine, each of two windings for stepper motor or each of there windings for BLDC engine(Ohm). Data type: float
FLT32	WindingInductance	Inductance of windings for DC engine, each of two windings for stepper motor or each of there windings for BLDC engine(mH). Data type: float
FLT32	RotorInertia	Rotor inertia(g cm2). Data type: float
FLT32	StallTorque	Torque hold position for a stepper motor or torque at a motionless rotor for other types of engines (mN m). Data type: float.
FLT32	DetentTorque	Holding torque position with un-powered coils (mN m). Data type: float.
FLT32	TorqueConstant	Torque constant, which determines the aspect ratio of maximum moment of force from the rotor current flowing in the coil (mN m / A). Used mainly for DC motors. Data type: float.
FLT32	SpeedConstant	Velocity constant, which determines the value or amplitude of the induced voltage on the motion of DC or BLDC motor (rpm / V) or stepper motor (steps/s / V). Data type: float.
FLT32	SpeedTorqueGradient	Speed torque gradient (rpm / mN m). Data type: float.
FLT32	MechanicalTimeConstant	Mechanical time constant (ms). Data type: float.
FLT32	MaxSpeed	The maximum speed for stepper motors (steps/s) or DC and BLDC motors (rmp). Data type: float.
FLT32	MaxCurrent	The maximum current in the winding (A). Data type: float.
FLT32	MaxCurrentTime	Safe duration of overcurrent in the winding (ms). Data type: float.
FLT32	NoLoadCurrent	The current consumption in idle mode (A). Used for DC and BLDC motors. Data type: float.
FLT32	NoLoadSpeed	Idle speed (rpm). Used for DC and BLDC motors. Data type: float.
INT8U	Reserved [24]	Reserved (24 bytes)
INT16U	CRC	Checksum

Description:

Read motor settings from EEPROM.

Command SENI

```
result_t set_encoder_information (device_t id, const encoder_information_t* encoder_information)
```

Command code (CMD): "seni" or 0x696E6573.

Request: (70 bytes)

INT32U	CMD	Command
CHAR	Manufacturer [16]	Manufacturer. Max string length: 16 chars.
CHAR	PartNumber [24]	Series and PartNumber. Max string length: 24 chars.
INT8U	Reserved [24]	Reserved (24 bytes)
INT16U	CRC	Checksum

Answer: (4 bytes)

INT32U	CMD	Command (answer)
--------	-----	------------------

Description:

Set encoder information to EEPROM. Can be used by manufacturer only.

Command GENI

```
result_t get_encoder_information (device_t id, encoder_information_t* encoder_information)
```

Command code (CMD): "geni" or 0x696E6567.

Request: (4 bytes)

INT32U	CMD	Command
--------	-----	---------

Answer: (70 bytes)

INT32U	CMD	Command (answer)
CHAR	Manufacturer [16]	Manufacturer. Max string length: 16 chars.
CHAR	PartNumber [24]	Series and PartNumber. Max string length: 24 chars.
INT8U	Reserved [24]	Reserved (24 bytes)
INT16U	CRC	Checksum

Description:

Read encoder information from EEPROM.

Command SENS

```
result_t set_encoder_settings (device_t id, const encoder_settings_t* encoder_settings)
```

Command code (CMD): "sens" or 0x736E6573.

Request: (54 bytes)

INT32U	CMD	Command
FLT32	MaxOperatingFrequency	Max operation frequency (kHz). Data type: float.
FLT32	SupplyVoltageMin	Minimum supply voltage (V). Data type: float.
FLT32	SupplyVoltageMax	Maximum supply voltage (V). Data type: float.
FLT32	MaxCurrentConsumption	Max current consumption (mA). Data type: float.
INT32U	PPR	The number of counts per revolution
INT32U	EncoderSettings	Encoder settings flags
		0x001 - ENCSET_DIFFERENTIAL_OUTPUT (If flag is set the encoder has differential output, else single ended output)
		0x004 - ENCSET_PUSH_PULL_OUTPUT (If flag is set the encoder has push-pull output, else open drain output)
		0x010 - ENCSET_INDEXCHANNEL_PRESENT (If flag is set the encoder has index channel, else encoder hasn't it)
		0x040 - ENCSET_REVOLUTIONSENSOR_PRESENT (If flag is set the encoder has revolution sensor, else encoder hasn't it)
		0x100 - ENCSET_REVOLUTIONSENSOR_ACTIVE_HIGH (If flag is set the revolution sensor active state is high logic state, else active state is low logic state)
INT8U	Reserved [24]	Reserved (24 bytes)
INT16U	CRC	Checksum

Answer: (4 bytes)

INT32U	CMD	Command (answer)
--------	-----	------------------

Description:

Set encoder settings to EEPROM. Can be used by manufacturer only.

Command GENS

```
result_t get_encoder_settings (device_t id, encoder_settings_t* encoder_settings)
```

Command code (CMD): "gens" or 0x736E6567.

Request: (4 bytes)

INT32U	CMD	Command
--------	-----	---------

Answer: (54 bytes)

INT32U	CMD	Command (answer)
FLT32	MaxOperatingFrequency	Max operation frequency (kHz). Data type: float.
FLT32	SupplyVoltageMin	Minimum supply voltage (V). Data type: float.
FLT32	SupplyVoltageMax	Maximum supply voltage (V). Data type: float.
FLT32	MaxCurrentConsumption	Max current consumption (mA). Data type: float.
INT32U	PPR	The number of counts per revolution
INT32U	EncoderSettings	Encoder settings flags
		0x001 - ENCSET_DIFFERENTIAL_OUTPUT (If flag is set the encoder has differential output, else single ended output)
		0x004 - ENCSET_PUSHPULL_OUTPUT (If flag is set the encoder has push-pull output, else open drain output)
		0x010 - ENCSET_INDEXCHANNEL_PRESENT (If flag is set the encoder has index channel, else encoder hasn't it)
		0x040 - ENCSET_REVOLUTIONSENSOR_PRESENT (If flag is set the encoder has revolution sensor, else encoder hasn't it)
		0x100 - ENCSET_REVOLUTIONSENSOR_ACTIVE_HIGH (If flag is set the revolution sensor active state is high logic state, else active state is low logic state)
INT8U	Reserved [24]	Reserved (24 bytes)
INT16U	CRC	Checksum

Description:

Read encoder settings from EEPROM.

Command SHSI

```
result_t set_hallsensor_information (device_t id, const hallsensor_information_t* hallsensor_information)
```

Command code (CMD): "shsi" or 0x69736873.

Request: (70 bytes)

INT32U	CMD	Command
CHAR	Manufacturer [16]	Manufacturer. Max string length: 16 chars.
CHAR	PartNumber [24]	Series and PartNumber. Max string length: 24 chars.
INT8U	Reserved [24]	Reserved (24 bytes)
INT16U	CRC	Checksum

Answer: (4 bytes)

INT32U	CMD	Command (answer)
--------	-----	------------------

Description:

Set hall sensor information to EEPROM. Can be used by manufacturer only.

Command GHSI

```
result_t get_hallsensor_information (device_t id, hallsensor_information_t* hallsensor_information)
```

Command code (CMD): "ghsi" or 0x69736867.

Request: (4 bytes)

INT32U	CMD	Command
--------	-----	---------

Answer: (70 bytes)

INT32U	CMD	Command (answer)
CHAR	Manufacturer [16]	Manufacturer. Max string length: 16 chars.
CHAR	PartNumber [24]	Series and PartNumber. Max string length: 24 chars.
INT8U	Reserved [24]	Reserved (24 bytes)
INT16U	CRC	Checksum

Description:

Read hall sensor information from EEPROM.

Command SHSS

```
result_t set_hallsensor_settings (device_t id, const hallsensor_settings_t* hallsensor_settings)
```

Command code (CMD): "shss" or 0x73736873.

Request: (50 bytes)

INT32U	CMD	Command
FLT32	MaxOperatingFrequency	Max operation frequency (kHz). Data type: float.
FLT32	SupplyVoltageMin	Minimum supply voltage (V). Data type: float.
FLT32	SupplyVoltageMax	Maximum supply voltage (V). Data type: float.
FLT32	MaxCurrentConsumption	Max current consumption (mA). Data type: float.
INT32U	PPR	The number of counts per revolution
INT8U	Reserved [24]	Reserved (24 bytes)
INT16U	CRC	Checksum

Answer: (4 bytes)

INT32U	CMD	Command (answer)
--------	-----	------------------

Description:

Set hall sensor settings to EEPROM. Can be used by manufacturer only.

Command GHSS

```
result_t get_hallsensor_settings (device_t id, hallsensor_settings_t* hallsensor_settings)
```

Command code (CMD): "ghss" or 0x73736867.

Request: (4 bytes)

INT32U	CMD	Command
--------	-----	---------

Answer: (50 bytes)

INT32U	CMD	Command (answer)
FLT32	MaxOperatingFrequency	Max operation frequency (kHz). Data type: float.
FLT32	SupplyVoltageMin	Minimum supply voltage (V). Data type: float.
FLT32	SupplyVoltageMax	Maximum supply voltage (V). Data type: float.
FLT32	MaxCurrentConsumption	Max current consumption (mA). Data type: float.
INT32U	PPR	The number of counts per revolution
INT8U	Reserved [24]	Reserved (24 bytes)
INT16U	CRC	Checksum

Description:

Read hall sensor settings from EEPROM.

Command SGRI

```
result_t set_gear_information (device_t id, const gear_information_t* gear_information)
```

Command code (CMD): "sgri" or 0x69726773.

Request: (70 bytes)

INT32U	CMD	Command
CHAR	Manufacturer [16]	Manufacturer. Max string length: 16 chars.
CHAR	PartNumber [24]	Series and PartNumber. Max string length: 24 chars.
INT8U	Reserved [24]	Reserved (24 bytes)
INT16U	CRC	Checksum

Answer: (4 bytes)

INT32U	CMD	Command (answer)
--------	-----	------------------

Description:

Set gear information to EEPROM. Can be used by manufacturer only.

Command GGRI

```
result_t get_gear_information (device_t id, gear_information_t* gear_information)
```

Command code (CMD): "ggri" or 0x69726767.

Request: (4 bytes)

INT32U	CMD	Command
--------	-----	---------

Answer: (70 bytes)

INT32U	CMD	Command (answer)
CHAR	Manufacturer [16]	Manufacturer. Max string length: 16 chars.
CHAR	PartNumber [24]	Series and PartNumber. Max string length: 24 chars.
INT8U	Reserved [24]	Reserved (24 bytes)
INT16U	CRC	Checksum

Description:

Read gear information from EEPROM.

Command SGRS

```
result_t set_gear_settings (device_t id, const gear_settings_t* gear_settings)
```

Command code (CMD): "sgrs" or 0x73726773.

Request: (58 bytes)

INT32U	CMD	Command
FLT32	ReductionIn	Input reduction coefficient. (Output = (ReductionOut / ReductionIn) * Input) Data type: float.
FLT32	ReductionOut	Output reduction coefficient. (Output = (ReductionOut / ReductionIn) * Input) Data type: float.
FLT32	RatedInputTorque	Max continuous torque (N m). Data type: float.
FLT32	RatedInputSpeed	Max speed on the input shaft (rpm). Data type: float.
FLT32	MaxOutputBacklash	Output backlash of the reduction gear(degree). Data type: float.
FLT32	InputInertia	Equivalent input gear inertia (g cm2). Data type: float.
FLT32	Efficiency	Reduction gear efficiency (%). Data type: float.
INT8U	Reserved [24]	Reserved (24 bytes)
INT16U	CRC	Checksum

Answer: (4 bytes)

INT32U	CMD	Command (answer)
--------	-----	------------------

Description:

Set gear settings to EEPROM. Can be used by manufacturer only.

Command GGRS

```
result_t get_gear_settings (device_t id, gear_settings_t* gear_settings)
```

Command code (CMD): "ggrs" or 0x73726767.

Request: (4 bytes)

INT32U	CMD	Command
--------	-----	---------

Answer: (58 bytes)

INT32U	CMD	Command (answer)
FLT32	ReductionIn	Input reduction coefficient. (Output = (ReductionOut / ReductionIn) * Input) Data type: float.
FLT32	ReductionOut	Output reduction coefficient. (Output = (ReductionOut / ReductionIn) * Input) Data type: float.
FLT32	RatedInputTorque	Max continuous torque (N m). Data type: float.
FLT32	RatedInputSpeed	Max speed on the input shaft (rpm). Data type: float.
FLT32	MaxOutputBacklash	Output backlash of the reduction gear(degree). Data type: float.
FLT32	InputInertia	Equivalent input gear inertia (g cm2). Data type: float.
FLT32	Efficiency	Reduction gear efficiency (%). Data type: float.
INT8U	Reserved [24]	Reserved (24 bytes)
INT16U	CRC	Checksum

Description:

Read gear settings from EEPROM.

Command SACC

```
result_t set_accessories_settings (device_t id, const accessories_settings_t* accessories_settings)
```

Command code (CMD): "sacc" or 0x63636173.

Request: (114 bytes)

INT32U	CMD	Command
CHAR	MagneticBrakeInfo [24]	The manufacturer and the part number of magnetic brake, the maximum string length is 24 characters.
FLT32	MBRatedVoltage	Rated voltage for controlling the magnetic brake (B). Data type: float.
FLT32	MBRatedCurrent	Rated current for controlling the magnetic brake (A). Data type: float.
FLT32	MBTorque	Retention moment (mN m). Data type: float.
INT32U	MBSettings	Flags of magnetic brake settings
		0x01 - MB_AVAILABLE (If flag is set the magnetic brake is available)
		0x02 - MB_POWERED_HOLD (If this flag is set the magnetic brake is on when powered)
CHAR	TemperatureSensorInfo [24]	The manufacturer and the part number of the temperature sensor, the maximum string length: 24 characters.
FLT32	TSMIn	The minimum measured temperature (degrees Celsius) Data type: float.
FLT32	TSMMax	The maximum measured temperature (degrees Celsius) Data type: float.
FLT32	TSGrad	The temperature gradient (V/degrees Celsius). Data type: float.
INT32U	TSSettings	Flags of temperature sensor settings.
		0x07 - TS_TYPE_BITS (Bits of the temperature sensor type)
		0x00 - TS_TYPE_UNKNOWN (Unknow type of sensor)
		0x01 - TS_TYPE_THERMOCOUPLE (Thermocouple)
		0x02 - TS_TYPE_SEMICONDUCTOR (The semiconductor temperature sensor)
		0x08 - TS_AVAILABLE (If flag is set the temperature sensor is available)
INT32U	LimitSwitchesSettings	Flags of limit switches settings.
		0x01 - LS_ON_SW1_AVAILABLE (If flag is set the limit switch connected to pin SW1 is available)
		0x02 - LS_ON_SW2_AVAILABLE (If flag is set the limit switch connected to pin SW2 is available)
		0x04 - LS_SW1_ACTIVE_LOW (If flag is set the limit switch connected to pin SW1 is triggered by a low level on pin)
		0x08 - LS_SW2_ACTIVE_LOW (If flag is set the limit switch connected to pin SW2 is triggered by a low level on pin)
		0x10 - LS_SHORTED (If flag is set the Limit switches is shorted)
INT8U	Reserved [24]	Reserved (24 bytes)
INT16U	CRC	Checksum

Answer: (4 bytes)

INT32U	CMD	Command (answer)
--------	-----	------------------

Description:

Set additional accessories information to EEPROM. Can be used by manufacturer only.

Command GACC

```
result_t get_accessories_settings (device_t id, accessories_settings_t* accessories_settings)
```

Command code (CMD): "gacc" or 0x63636167.

Request: (4 bytes)

INT32U	CMD	Command
--------	-----	---------

Answer: (114 bytes)

INT32U	CMD	Command (answer)
CHAR	MagneticBrakeInfo [24]	The manufacturer and the part number of magnetic brake, the maximum string length is 24 characters.
FLT32	MBRatedVoltage	Rated voltage for controlling the magnetic brake (B). Data type: float.
FLT32	MBRatedCurrent	Rated current for controlling the magnetic brake (A). Data type: float.
FLT32	MBTorque	Retention moment (mN m). Data type: float.
INT32U	MBSettings	Flags of magnetic brake settings
		0x01 - MB_AVAILABLE (If flag is set the magnetic brake is available)
		0x02 - MB_POWERED_HOLD (If this flag is set the magnetic brake is on when powered)
CHAR	TemperatureSensorInfo [24]	The manufacturer and the part number of the temperature sensor, the maximum string length: 24 characters.
FLT32	TSMIn	The minimum measured temperature (degrees Celsius) Data type: float.
FLT32	TSMMax	The maximum measured temperature (degrees Celsius) Data type: float.
FLT32	TSGrad	The temperature gradient (V/degrees Celsius). Data type: float.
INT32U	TSSettings	Flags of temperature sensor settings.
		0x07 - TS_TYPE_BITS (Bits of the temperature sensor type)
		0x00 - TS_TYPE_UNKNOWN (Unknow type of sensor)
		0x01 - TS_TYPE_THERMOCOUPLE (Thermocouple)
		0x02 - TS_TYPE_SEMICONDUCTOR (The semiconductor temperature sensor)
		0x08 - TS_AVAILABLE (If flag is set the temperature sensor is available)
INT32U	LimitSwitchesSettings	Flags of limit switches settings.
		0x01 - LS_ON_SW1_AVAILABLE (If flag is set the limit switch connected to pin SW1 is available)
		0x02 - LS_ON_SW2_AVAILABLE (If flag is set the limit switch connected to pin SW2 is available)
		0x04 - LS_SW1_ACTIVE_LOW (If flag is set the limit switch connected to pin SW1 is triggered by a low level on pin)
		0x08 - LS_SW2_ACTIVE_LOW (If flag is set the limit switch connected to pin SW2 is triggered by a low level on pin)
		0x10 - LS_SHORTED (If flag is set the Limit switches is shorted)
INT8U	Reserved [24]	Reserved (24 bytes)
INT16U	CRC	Checksum

Description:

Read additional accessories information from EEPROM.

Bootloader commands**Command GBLV**

```
result_t get_bootloader_version (device_t id, unsigned int* Major, unsigned int* Minor, unsigned int* Release)
```

Command code (CMD): "gblv" or 0x766C6267.

Request: (4 bytes)

INT32U	CMD	Command
--------	-----	---------

Answer: (10 bytes)

INT32U	CMD	Command (answer)
INT8U	Major	Bootloader major version number
INT8U	Minor	Bootloader minor version number
INT16U	Release	Bootloader release version number
INT16U	CRC	Checksum

Description:

Read controller's firmware version.

Command IRND

```
result_t get_init_random (device_t id, init_random_t* init_random)
```

Command code (CMD): "irnd" or 0x646E7269.

Request: (4 bytes)

INT32U	CMD	Command
--------	-----	---------

Answer: (24 bytes)

INT32U	CMD	Command (answer)
INT8U	key [16]	Random key.
INT8U	Reserved [2]	Reserved (2 bytes)
INT16U	CRC	Checksum

Description:

Read random number from controller.

Command GUID

```
result_t get_globally_unique_identifier (device_t id, globally_unique_identifier_t* globally_unique_identifier)
```

Command code (CMD): "guid" or 0x64697567.

Request: (4 bytes)

INT32U	CMD	Command
--------	-----	---------

Answer: (40 bytes)

INT32U	CMD	Command (answer)
INT32U	UniqueID0	Unique ID 0.
INT32U	UniqueID1	Unique ID 1.
INT32U	UniqueID2	Unique ID 2.
INT32U	UniqueID3	Unique ID 3.
INT8U	Reserved [18]	Reserved (18 bytes)
INT16U	CRC	Checksum

Description:

This value is unique to each individual die but is not a random value. This unique device identifier can be used to initiate secure boot processes or as a serial number for USB or other end applications.

Command CHMT

```
result_t command_change_motor (device_t id, const command_change_motor_t* the_command_change_motor)
```

Command code (CMD): "chmt" or 0x746D6863.

Request: (22 bytes)

INT32U	CMD	Command
INT8U	Motor	Motor number which it should be switch relay on [0..1]
INT8U	Reserved [15]	Reserved (15 bytes)
INT16U	CRC	Checksum

Answer: (4 bytes)

INT32U	CMD	Command (answer)
--------	-----	------------------

Description:

Change motor - command for switching output relay.

Controller error response types

ERRC**Answer:** (4 bytes)**Code:** "errc" or 0x63727265

INT32U	"errc"	Command error
--------	--------	---------------

Description:

Controller answers with "errc" if the command is either not recognized or cannot be processed and sets the corresponding bit in status data structure.

ERRD**Answer:** (4 bytes)**Code:** "errd" or 0x64727265

INT32U	"errd"	Data error
--------	--------	------------

Description:

Controller answers with "errd" if the CRC of the data section computed by the controller doesn't match the received CRC field and sets the corresponding bit in status data structure.

ERRV**Answer:** (4 bytes)**Code:** "errv" or 0x76727265

INT32U	"errv"	Value error
--------	--------	-------------

Description:

Controller answers with "errv" if any of the values in the command are out of acceptable range and can not be applied. Inacceptable value is replaced by a rounded, truncated or default value. Controller also sets the corresponding bit in status data structure.

6.3. 8SMC1-USBhF software compatibility

New motor controllers can be used with the software written for the 8SMC1-USBhF series. There are two options available to control new motor controllers using 8SMC1-USBhF-compatible software:

1. Recommended. Use MicroSMC software with support for both 8SMC1-USBhF and new motor controllers. In this case MicroSMC process will open all found motor controllers in exclusive mode to arbitrate access and it will be possible to control them through USMCDLL, which uses MicroSMC.

Download MicroSMC with support for new motor controllers on the [Software](#) page.

2. Use USMCDLL/libximc compatibility library to control motor controllers without MicroSMC software. Use this option if you need to simultaneously run MicroSMC and work with some motor controllers using libximc library.

Download USMCDLL/libximc compatibility library [here](#).

The table below shows the mapping from 8SMC1-USBhF to new motor controller functions: first column lists USMCDLL library functions, second column lists corresponding paragraph in 8SMC1-USBhF controller user's manual, third column contains this function features in the migration library.

Function call	8SMC1-USBhF	New motor controller
USMC_Init	7.5.3	Uses libximc enumerate_devices , get_enumerate_device_information , get_enumerate_device_serial , get_device_count , get_device_name , open_device functions. Queries all COM-ports present in the system.
USMC_GetState	7.5.4	Uses libximc get_status and get_engine_settings functions. AReset, EMReset, RotTrErr flags in USMC_State structure are always set to false.
USMC_SaveParametersToFlash	7.5.5	Uses libximc command_save_settings function.
USMC_GetMode	7.5.6	Uses libximc get_edges_settings , get_power_settings , get_control_settings , get_ctp_settings , get_sync_out_settings functions. EMReset, ResetRT, SyncOUTR, EncoderEn, EncoderInv, ResBEnc, ResEnc flags in USMC_Mode are always set to false, SyncINOp flag is always set to true.
USMC_SetMode	7.5.7	Uses all functions used by USMC_GetMode and their "set_" equivalents. Ignores RotTeEn, RotTrOp, ResetRT, SyncOUTR, SyncINOp, EncoderEn flags.
USMC_GetParameters	7.5.8	Uses libximc get_secure_settings , get_engine_settings , get_move_settings , get_feedback_settings , get_power_settings , get_control_settings , get_ctp_settings , get_home_settings , get_sync_out_settings functions. Returns zeroes in BTimeoutR, BTimeoutD, MinP, MaxLoft, StartPos fields.
USMC_SetParameters	7.5.9	Uses all functions used by USMC_GetParameters and their "set_" equivalents. Ignores BTimeoutR, BTimeoutD, MinP, MaxLoft, StartPos parameters.
USMC_GetStartParameters	7.5.10	Uses libximc get_move_settings , get_engine_settings functions. WSyncIN, SyncOUTR, ForceLoft flags in USMC_StartParameters structure are always set to false.
USMC_Start	7.5.11	Uses libximc get_move_settings , get_engine_settings , set_move_settings , set_engine_settings , command_move functions.
USMC_Stop	7.5.12	Uses libximc command_stop function.
USMC_SetCurrentPosition	7.5.13	Uses libximc set_position function.
USMC_GetEncoderState	7.5.14	Uses libximc get_status function.
USMC_GetLastErr	7.5.15	Does not modify its arguments. Error status is indicated by the nonzero return code of the corresponding USMC_ function.
USMC_Close	7.5.16	Uses libximc close_device function.

Migration library does not require and does not interact with background MicroSMC.exe process. It uses libximc.dll library to interface with new motor controllers.

All composite USMC_ functions containing several libximc function calls terminate if any of the underlying libximc functions returns an error. In this case controller may be left with partially saved settings. Nonzero return code of USMC_ functions is equal to the return code of the libximc function which returned an error.

Application example: [usmcdll_libximc_test.zip](#)

6.4. Libximc library timeouts

A number of timeouts and wait times are used when working with [XiLab](#) program or your own application using [libximc library](#) to detect errors and support robust controller operation. A list of times is provided below, together with reasons. Times are optimized for the USB connection on a modern PC. It is important to take delays into account when designing your own signal transmission lines to avoid erroneous timeouts.

Condition	Name	Time milliseconds	in
Enumeration timeout. Happens if device type cannot be determined.	ENUMERATE_TIMEOUT_TIME	100	
Port open timeout. Happens if library cannot open port.	DEFAULT_TIMEOUT_TIME	5000	
Wait time when no data is received from device.	DEFAULT_TIMEOUT_TIME	5000	
Wait time on device open.	RESET_TIME/2	50	
Wait time from controller reset to device reappearance on firmware reflash.	RESET_TIME*1.2 DEFAULT_TIMEOUT_TIME	5120	+
Wait time on flash sector write.	FLASH_SECTIONWRITE_TIME	100	
Reconnect timeout on flash update .	XISM_PORT_DETECT_TIME	60000	

6.5. XILab scripts

XILab scripting language is implemented using QtScript, which in turn is based on ECMAScript. ECMAScript is the scripting language standardized by Ecma International in the ECMA-262 specification and ISO/IEC 16262.

QtScript (and, by extension, XILab) uses [third edition of the ECMAScript standard](#).

Brief description of the language

Data Types

ECMAScript supports nine primitive data types. Values of type Reference, List, and Completion are used only as intermediate results of expression evaluation and cannot be stored as properties of objects. The rest of the types are:

- Undefined,
- Null,
- Boolean,
- String,
- Number,
- Object.

Statements

Most common ECMAScript language statements are summarized below:

6.5. XILab scripts

Brief description of the language

- Data Types
- Statements
- Variable statements
- Reserved words
- Functions

Syntax highlighting

Additional XILab functions

- XILab log
- Script execution delay
- New axis object creation
- New file object creation
- Creation of calibration structure
- Get next serial
- Wait for stop
- libximc library functions

Examples

- Cyclic movement script
- A script which scans and writes data to the file
- A script which moves the controller through the list of positions with pauses
- A script which enumerates all available axes and gets their coordinates
- Bitmask example script

Name	Usage	Description
Block	{[<statement list>]}	Several statements may be grouped into a block using braces.
Variable declaration	var <variable declaration list>	Variables are declared using "var" keyword.
Empty statement	;	Semicolon denotes an empty instruction. It is not required to end a line with a semicolon.
Conditional execution	if (<condition>) <instruction> [else <instruction>]	Conditional execution is done using "if ... else" keywords. If a condition is true, then "if"-block instruction is executed, else an "else"-block instruction is executed.
Loop	do <loop body> while (<condition>) while (<condition>) <loop body> for ([<initialization>]; [<condition>]; [<iterative statement>]) <loop body>	Loops have several forms. A "do ... while ..." loop executes loop body and then checks if condition is true or false to see whether it should stop or continue running. A "while ... do ..." loop repeatedly checks the condition and executes loop body if it is true. A "for ..." loop executes an initialization statement once, then executes an iterative statement and loop body while the condition is true.
Return	return [<expression>]	Stops function execution and returns expression as a result.
Exception	throw <expression>	Generates or "throws" an exception, which may be processed by the "try" statement (see below).
Try-catch block	try <block> catch (<identifier>) <block> try <block> finally <block> try <block> catch (<identifier>) <block> finally <block>	Used together with exceptions. This statement tries to execute its "try"-block. If an exception is thrown in it, then a "catch"-block is executed. Finally a "finally"-block is executed unconditionally. Either a "catch" or a "finally" block may be omitted.

Variable statements

Variables are declared using `var` keyword. A declared variable is placed within visibility scope that corresponds to the function in which it is declared. If the variable is declared outside of functions, it is placed in the global visibility scope. Variable is created when the function within which it was declared, or, if the variable is global, at the start of the application. When a variable is created it is initialized with `Undefined` value. If a variable is created with initialization, the initialization does not occur in the moment of variable creation, it happens when the string with the `var` statement executes.

Reserved words

The following words are the reserved keywords in the language and may not be used as identifiers:

```
break    else    new    var
case    finally    return    void
catch    for    switch    while
continue    function    this    with
default    if    throw
delete    in    try
do    instanceof    typeof
```

The following words are used as keywords in proposed extensions and are therefore reserved to allow for the possibility of future adoption of those extensions:

```
abstract    enum    int    short
boolean    export    interface    static
byte    extends    long    super
char    final    native    synchronized
class    float    package    throws
const    goto    private    transient
debugger    implements    protected    volatile
double    import    public
```

Functions

Functions are objects in ECMAScript. Functions like any other objects can be stored in variables, objects and arrays, can be passed as arguments to other functions and can be returned by functions. Functions, like any other objects may have properties. Essential specific feature of functions is that they can be invoked.

In the application text, the most common way to define a function is:

```
function sum(arg1, arg2) { // a function which takes two parameters
    return arg1 + arg2;    // and returns their sum
}
```

Syntax highlighting

Script window text has syntax highlighting. Its colors are:

Statement type	color	text example
Arbitrary functions	purple	<code>my_function();</code>
XILab functions	blue	<code>get_status();</code>
Positive numbers	green	<code>a = 100;</code>
Negative numbers	red	<code>b = -200;</code>
Comments	grey	<code>// a comment</code>
The rest of the text	black	<code>var s = "a string";</code>

During the script execution the background of line with the last executed command is changed to dark gray with update rate of once in every 20 ms.

Additional XILab functions

This image shows XILab functions which are available from scripts, aside from standard built-in language functions.

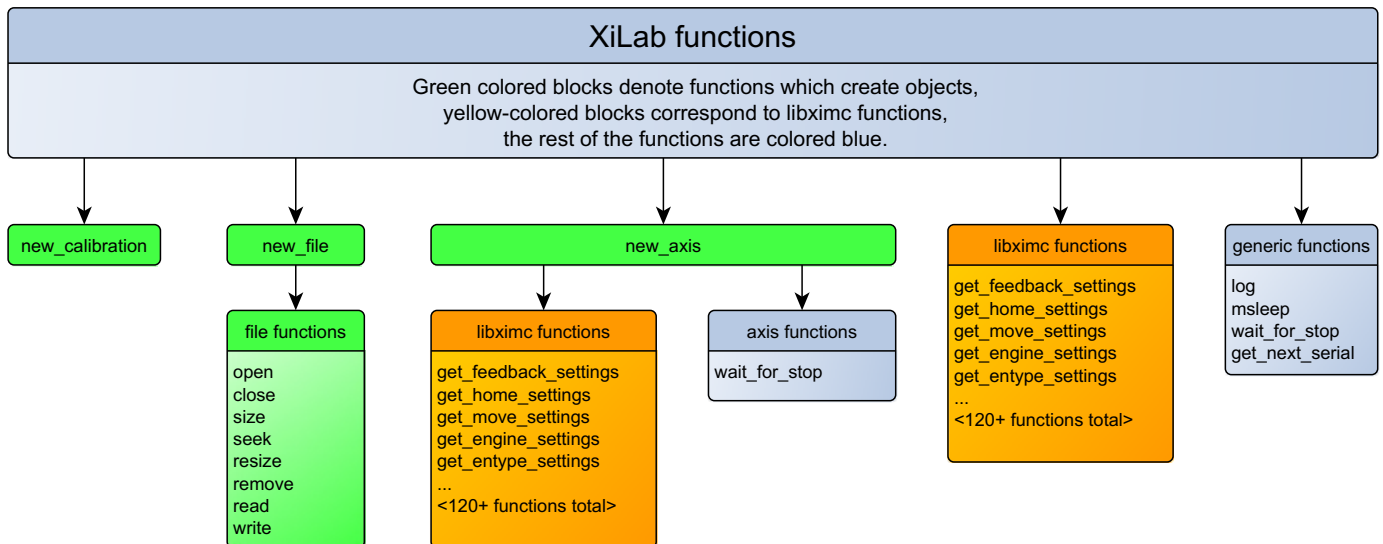

- `log(string text [, int loglevel])` – save text to the XILab log
- `msleep(int ms)` - delay script execution
- `new_axis(int serial_number)` - create new axis object
- `new_file(string filename)` - create new file object
- `new_calibration(int A, int Microstep)` - create calibration structure to pass to calibrated functions
- `get_next_serial(int serial)` - get next serial out of an ordered list of opened controller serials
- `command_wait_for_stop(int refresh_period)` - wait until controller stops moving
- and all libximc library functions (see [Programming guide](#))

Also, all constant values from the communication protocol are defined and can be used in scripts. [Usage example](#).

XILab log

Logging is done by calling `log(string text [, int loglevel])` function.

This function adds the *text* line to the XILab log. If the second *loglevel* parameter is passed the message receives the appropriate logging level and is displayed in corresponding color.

Loglevel	Type
1	Error
2	Warning
3	Info

Example:

```
var x = 5;
log("x = " + x);
```

Function usage example

Note: It is not recommended to invoke functions that interact with XILab user interface (i.e. logging function) with a frequency of more than once in 20 ms.

Script execution delay

Script is paused by calling the `msleep(int ms)` function, which suspends script execution for *ms* milliseconds.

Example:

```
msleep(200);
```

Function usage example.

New axis object creation

XILab multi-axis interface provides the ability to manage controllers via scripts. The difference from the single-axis case is that you should specify the controller which receives the command. An "axis" object is introduced to abstract this concept. It has methods which match the **libximc library** function names. Controllers are identified by their serial numbers.

Example:

```
var x = new_axis(123);
x.command_move(50);
```

In this example first line of the script creates an axis-type object with the variable name "x", which tries to use controller with the serial number "123". If this controller is not connected, then the script will return an error and terminate. The second line of the script sends a "move to position 50" command to this controller.

[Function usage example.](#)

New file object creation

XILab scripts can read from and write to files. To do this you need to create a "file" object, passing desired filename in its constructor. File object has the following functions:

<i>return_type</i> Function_name	Description
<i>bool</i> open()	Opens the file. File is opened in read-write mode if possible, in read-only mode otherwise.
<i>void</i> close()	Closes the file.
<i>Number</i> size()	Returns file size in bytes.
<i>bool</i> seek(<i>Number</i> pos)	Sets current position in file to <i>pos</i> bytes ¹ .
<i>bool</i> resize(<i>Number</i> size)	Resizes the file to <i>size</i> bytes. If <i>size</i> is less than current file size, then the file is truncated, if it is greater than current file size, then the file is padded with zero bytes.
<i>bool</i> remove()	Removes the file.
<i>String</i> read(<i>Number</i> maxsize)	Reads up to <i>maxsize</i> bytes from the file and returns result as a string. Data is read in utf-8 Unicode encoding.
<i>Number</i> write(<i>String</i> s, <i>Number</i> maxsize)	Writes up to <i>maxsize</i> bytes to the file from the string. Data is written in utf-8 unicode encoding, end-of-line character should be set by user. Returns amount of written bytes or -1 if an error occurred.

All file functions which return *bool* type, return "true" on success and "false" on failure. Use "/" symbol as path separator, this works on all systems (Windows/Linux/Mac).

¹ Seeking beyond the end of a file: If the position is beyond the end of a file, then seek() shall not immediately extend the file. If a write is performed at this position, then the file shall be extended. The content of the file between the previous end of file and the newly written data is UNDEFINED and varies between platforms and file systems.

Example:

```
var winf = new_file("C:/file.txt"); // An example of file name and path on Windows
var linf = new_file("/home/user/Desktop/file.txt"); // An example of file name and path on Linux
var macf = new_file("/Users/macuser/file.txt"); // An example of file name and path on Mac

var f = winf; // Pick a file name
if (f.open()) { // Try to open the file
    f.write("some text"); // If successful, then write desired data to the file
    f.close(); // Close the file
} else { // If file open failed for some reason
    log("Failed opening file"); // Log an error
}
```

[Function usage example.](#)

Creation of calibration structure

new_calibration(double A, int Microstep) function takes as a parameter a floating point number A, which sets the ratio of user units to motor steps, and microstep division mode, which was either read earlier from MicrostepMode field of get_engine_settings() return type, or set by a MICROSTEP_MODE_ constant. This function returns calibration_t structure, which should be passed to calibrated get/_set_ functions to get or set values in user units. The following two forms are functionally equivalent:

```
// create calibration: type 1
var calb = new_calibration(c1, c2);
```

```
// create calibration: type 2
var calb = new Object();
calb.A = c1;
calb.MicrostepMode = c2;
```

[Function usage example.](#)

Get next serial

`get_next_serial(int serial)` function takes as a parameter an integer number and returns the smallest serial from a sorted list of opened controller serials which is strictly greater than the parameter. If there are no such serials a zero is returned.

This function is a convenient shortcut for automatic creation of "axis" type objects without hardcoded serial numbers.

Example:

```
var first_serial = get_next_serial(0);
var x = new_axis(first_serial);
var y = new_axis(get_next_serial(first_serial));
```

In this example in the first line we obtain a serial, in the second line an axis-type object is created, in the third line we get the next serial and create an axis for it.

[Function usage example.](#)

Wait for stop

The `command_wait_for_stop(int refresh period)` script function waits until the controller stops movement, that is, until the `MVCMD_RUNNING` bit in the `MvCmdSts` member of the structure returned by the `get_status()` function becomes unset. `command_wait_for_stop` script function uses `command_wait_for_stop` libximc function and takes as a parameter an integer denoting time delay in milliseconds between successive queries of controller state.

This function is also present as a method of an "axis"-type object.

[Function usage example.](#)

libximc library functions

Libximc library functions with "get_" prefix read settings from the controller and return the corresponding settings structure. Libximc library functions with "set_" prefix take as a parameter a settings data structure and write these settings to the controller. There are two ways to set data structure contents:

1. call the corresponding get-function and modify required fields

```
// set settings: type 1
var m = get_move_settings();
m.Speed = 100;
set_move_settings(m);
```

2. create an *Object* and set all of its *properties* that are present as members of the data structure (case-sensitive).

```
// set settings: type 2
var m = new Object;
m.Speed = 100;
m.uSpeed = 0;
m.Accel = 300;
m.Decel = 500;
m.AntiplaySpeed = 10;
m.uAntiplaySpeed = 0;
set_move_settings(m);
```

Please note, that in the first case controller receives an additional command (sent by the get-function before the set-). In the second case one should initialize all object properties corresponding to structure members. Any missing property will be initialized with zero. Any property that does not match a structure member name will be ignored. Any property with non-matching type will be typecast according to EcmaScript rules. All data structures are described in [Communication protocol specification](#) chapter of the manual.

[Function usage example.](#)

Examples

This section contains examples of typical tasks which can be easily automated by XILab scripts.

Cyclic movement script

```
var first_border = -10; // first border coordinate in mm
var second_border = 10; // second border coordinate in mm
var mm_per_step = 0.005; // steps to distance translation coefficient
var delay = 100; // delay in milliseconds
var calb = new_calibration(mm_per_step, get_engine_settings().MicrostepMode); // create calibration structure
command_stop(); // send STOP command (does immediate stop)
command_zero(); // send ZERO command (sets current position and encoder value to zero)
while (1) { // infinite loop
  command_move_calb(first_border, calb); // move towards one border
  command_wait_for_stop(delay); // wait until controller stops moving
  command_move_calb(second_border, calb); // move towards another border
  command_wait_for_stop(delay); // wait until controller stops moving
}
```

A script which scans and writes data to the file

```

var start = 0; // Starting coordinate in steps
var step = 10; // Shift amount in steps
var end = 100; // Ending coordinate in steps

var speed = 300; // maximum movement speed in steps / second
var accel = 100; // acceleration value in steps / second^2
var decel = 100; // deceleration value in steps / second^2
var delay = 100;

var m = get_move_settings(); // read movement settings from the controller
m.Speed = speed; // set movement speed
m.Accel = accel; // set acceleration
m.Decel = decel; // set deceleration
set_move_settings(m); // write movement settings into the controller

var f = new file("C:/a.csv"); // Choose a file name and path
f.open(); // Open a file
f.seek( 0 ); // Seek to the beginning of the file

command_move(start); // Move to the starting position
command_wait_for_stop(delay); // Wait until controller stops moving

while (get_status().CurPosition < end) {
    f.write( get_status().CurPosition + "," + get_chart_data().Pot + "," + Date.now() + "\n" ); // Get current position, potentiometer value and date and write them to file
    command_movr(step); // Move to the next position
    command_wait_for_stop(delay); // Wait until controller stops moving
}
f.close(); // Close the file

```

A script which moves the controller through the list of positions with pauses

```

var axis = new_axis(get_next_serial(0)); // Use first available controller
var x; // A helper variable, represents coordinate
var ms; // A helper variable, represents wait time in milliseconds
var f = new_file("./move_and_sleep.csv"); // Choose a file name and path; this script uses a file from examples in the installation directory
f.open(); // Open a file
while ( str = f.read(4096) ) { // Read file contents string by string, assuming each string is less than 4 KiB long
    var ar = str.split(","); // Split the string into substrings with comma as a separator; the result is an array of strings
    x = ar[0]; // Variable assignment
    ms = ar[1]; // Variable assignment
    log( "Moving to coordinate " + x ); // Log the event
    axis.command_move(x); // Move to the position
    axis.command_wait_for_stop(100); // Wait until the movement is complete
    log( "Waiting for " + ms + " ms" ); // Log the event
    msleep(ms); // Wait for the specified amount of time
}
log ( "The end." );
f.close(); // Close the file

```

[move_and_sleep.csv](#) - a sample file for use with the above example

A script which enumerates all available axes and gets their coordinates

```

var i = 0; // Declare loop iteration variable
var serial = 0; // Declare serial number variable
var axes = Array(); // Declare axes array
while (true) { // The loop
    serial = get_next_serial(serial); // Get next serial
    if (serial == 0) // If there are no more controllers then...
        break; // ...break out of the loop
    var a = new Object(); // Create an object
    a.serial = serial; // Assign serial number to its "serial" property
    a.handle = new_axis(serial); // Assign new axis object to its "handle" property
    axes[i] = a; // Add it to the array
    i++; // Increment counter
}
for (var k=0; k < axes.length; k++) { // Iterate through array elements
    log ( "Axis with S/N " + axes[k].serial + " is in position " + axes[k].handle.get_status().CurPosition );
    // For each element print saved axis serial and call a get_status() function
}

```

Bitmask example script

```

/*
  Bitmask example script
*/
var a = new_axis(get_next_serial(0)); // take first found axis
var gets = a.get_status(); // read status once and reuse it

var gpio = gets.GPIOFlags;
var left = STATE_LEFT_EDGE;
var right = STATE_RIGHT_EDGE;
var mask = left | right;
var result = gpio & mask;
log( to_binary(left) + " = left limit switch flag" );
log( to_binary(right) + " = right limit switch flag" );
log( to_binary(mask) + " = OR operation on flags gives the mask" );
log( to_binary(gpio) + " = gpio state" );
log( to_binary(result) + " = AND operation on state and mask gives result" );
if ( result ) {
  log("At least one limit switch is on");
} else {
  log("Both limit switches are off");
}

// Binary representation function
function to_binary(i)
{
  bits = 32;
  x = i >>> 0; // coerce to unsigned in case we need to print negative ints
  str = x.toString(2); // the binary representation string
  return (repeat("0", bits) + str).slice (-bits); // pad with zeroes and return
}

// String repeat function
function repeat(str, times)
{
  var result="";
  var pattern=str;
  while (times > 0) {
    if (times&1) {
      result+=pattern;
    }
    times>>=1;
    pattern+=pattern;
  }
  return result;
}

```

7. Files

1. Configuration files
2. Software

7.1. Configuration files

1. [Translation Stages](#)
2. [Rotation Stages](#)
3. [Vertical Translation Stages](#)
4. [Screws and Actuators](#)
5. [Motorized Goniometers](#)
6. [Mirror Mounts](#)
7. [Motorized Attenuators](#)
8. [Motorized Iris Diaphragms](#)

Translation Stages



8MT160 - Motorized Delay Line



8MT295 - Long-Travel Motorized Linear Stages



8MT195 - Long-Travel Motorized Linear Stages



8MT167 - Motorized Translation Stage



8MT173 - Motorized Translation Stages



8MT173DC - Motorized Translation Stages



8MT50 - Motorized Translation Stages



8MT30 - Narrow Motorized Translation Stages



8MT175 - Motorized Translation Stages

8MT175-100

8MT175-50



8MT177 - Motorized Translation Stage



8MT184 - Motorized Translation Stage



8MT193 - Motorized Translation Stage



8MT200 - Motorized Translation Stages



8MTF - Motorized XY Scanning Stage



8MTF2 - Motorized Fiber Coupling Stage



8MTFV - Motorized Translation Stage



8MT60 - Motorized Translation Stage

8MT160 - Motorized Delay Line

Update: 15 March 2018

Part number	Travel range	Units	Profile	Positioner	Motor	Encoder	Brake	Accessories	Peripherals	Attenuator	Controller	XILab
8MT160-300	300	mm	8MT160-300.cfg	8MT160	4247R	NoEnc	NoBrake	NoAcc	Buttons	NoAtten	XismusbDef	XIDef
8MT160-300-MEn1	300	mm	8MT160-300-MEn1.cfg	8MT160	4247R	HEDM5500R	NoBrake	NoAcc	Buttons	NoAtten	XismusbDef	XIDef

8MT295 - Long-Travel Motorized Linear Stages

Update: 15 March 2018

Part number	Travel range	Units	Profile	Positioner	Motor	Encoder	Brake	Accessories	Peripherals	Attenuator	Controller	XILab
8MT295X-240-2.5-DC	240	mm	8MT295X-240-2.5-DC.cfg	8MT295-2.5	Maxon-370355	HEDL5540	NoBrake	NoAcc	Buttons	NoAtten	XismusbDef	XIDef
8MT295X-340-2.5	340	mm	8MT295X-340-2.5.cfg	8MT295-2.5	5918-R	NoEnc	NoBrake	NoAcc	Buttons	NoAtten	XismusbDef	XIDef
8MT295X-540-4	540	mm	8MT295X-540-4.cfg	8MT295-4	5918-R	NoEnc	NoBrake	NoAcc	Buttons	NoAtten	XismusbDef	XIDef
8MT295X-740-5	740	mm	8MT295X-740-5.cfg	8MT295-5-740	5918-R	NoEnc	NoBrake	NoAcc	Buttons	NoAtten	XismusbDef	XIDef
8MT295X-840-10	840	mm	8MT295X-840-10.cfg	8MT295-10	5918-R	NoEnc	NoBrake	NoAcc	Buttons	NoAtten	XismusbDef	XIDef
8MT295X-1040-5	1040	mm	8MT295X-1040-5.cfg	8MT295-5-1040	5918-R	NoEnc	NoBrake	NoAcc	Buttons	NoAtten	XismusbDef	XIDef
8MT295Z-340-2.5	340	mm	8MT295Z-340-2.5.cfg	8MT295-2.5	5918-R	NoEnc	BRAKE-AB41	NoAcc	Buttons	NoAtten	XismusbDef	XIDef
8MT295Z-540-4	540	mm	8MT295Z-540-4.cfg	8MT295-4	5918-R	NoEnc	BRAKE-AB41	NoAcc	Buttons	NoAtten	XismusbDef	XIDef
8MT295Z-740-5	740	mm	8MT295Z-740-5.cfg	8MT295-5-740	5918-R	NoEnc	BRAKE-AB41	NoAcc	Buttons	NoAtten	XismusbDef	XIDef
8MT295Z-840-10	840	mm	8MT295Z-840-10.cfg	8MT295-10	5918-R	NoEnc	BRAKE-AB41	NoAcc	Buttons	NoAtten	XismusbDef	XIDef

8MT195 - Long-Travel Motorized Linear Stages

Update: 15 March 2018

Part number	Travel range	Units	Profile	Positioner	Motor	Encoder	Brake	Accessories	Peripherals	Attenuator	Controller	XILab
8MT195X-340-2.5	340	mm	8MT195X-340-2.5.cfg	8MT195-2.5	5918-R	NoEnc	NoBrake	NoAcc	Buttons	NoAtten	XismusbDef	XIDef
8MT195X-540-4	540	mm	8MT195X-540-4.cfg	8MT195-4	5918-R	NoEnc	NoBrake	NoAcc	Buttons	NoAtten	XismusbDef	XIDef
8MT195X-540-10	540	mm	8MT195X-540-10.cfg	8MT195-10	5918-R	NoEnc	NoBrake	NoAcc	Buttons	NoAtten	XismusbDef	XIDef
8MT195X-740-5	740	mm	8MT195X-740-5.cfg	8MT195-5-740	5918-R	NoEnc	NoBrake	NoAcc	Buttons	NoAtten	XismusbDef	XIDef
8MT195X-840-10	840	mm	8MT195X-840-10.cfg	8MT195-10	5918-R	NoEnc	NoBrake	NoAcc	Buttons	NoAtten	XismusbDef	XIDef
8MT195X-1040-10	1040	mm	8MT195X-1040-10.cfg	8MT195-10	5918-R	NoEnc	NoBrake	NoAcc	Buttons	NoAtten	XismusbDef	XIDef
8MT195Z-240-2.5-DC	240	mm	8MT195Z-240-2.5-DC.cfg	8MT195-2.5	Maxon-370355	HEDL9140	BRAKE-AB41	NoAcc	Buttons	NoAtten	XismusbDef	XIDef
8MT195Z-240-2.5	240	mm	8MT195Z-240-2.5.cfg	8MT195-2.5	5918-R	NoEnc	BRAKE-AB41	NoAcc	Buttons	NoAtten	XismusbDef	XIDef
8MT195Z-340-2.5	340	mm	8MT195Z-340-2.5.cfg	8MT195-2.5	5918-R	NoEnc	BRAKE-AB41	NoAcc	Buttons	NoAtten	XismusbDef	XIDef
8MT195Z-540-4	540	mm	8MT195Z-540-4.cfg	8MT195-4	5918-R	NoEnc	BRAKE-AB41	NoAcc	Buttons	NoAtten	XismusbDef	XIDef
8MT195Z-740-5	740	mm	8MT195Z-740-5.cfg	8MT195-5-740	5918-R	NoEnc	BRAKE-AB41	NoAcc	Buttons	NoAtten	XismusbDef	XIDef
8MT195Z-840-10	840	mm	8MT195Z-840-10.cfg	8MT195-10	5918-R	NoEnc	BRAKE-AB41	NoAcc	Buttons	NoAtten	XismusbDef	XIDef

8MT167 - Motorized Translation Stage

Update: 15 March 2018

Part number	Travel range	Units	Profile	Positioner	Motor	Encoder	Brake	Accessories	Peripherals	Attenuator	Controller	XILab
8MT167-100	100	mm	8MT167-100.cfg	8MT167	4247R	NoEnc	NoBrake	NoAcc	Buttons	NoAtten	XismusbDef	XIDef
8MT167-100-28	100	mm	8MT167-100-28.cfg	8MT167	28R	NoEnc	NoBrake	NoAcc	Buttons	NoAtten	XismusbDef	XIDef
8MT167-100C28	100	mm	8MT167-100C28.cfg	8MT167	28R	NoEnc	NoBrake	NoAcc	Buttons	NoAtten	XismusbDef	XIDef
8MT167S-100	100	mm	8MT167S-100.cfg	8MT167	4247R	NoEnc	NoBrake	NoAcc	Buttons	NoAtten	XismusbDef	XIDef
8MT167S-100-28	100	mm	8MT167S-100-28.cfg	8MT167	28R	NoEnc	NoBrake	NoAcc	Buttons	NoAtten	XismusbDef	XIDef
8MT167S-100C28	100	mm	8MT167S-100C28.cfg	8MT167	28R	NoEnc	NoBrake	NoAcc	Buttons	NoAtten	XismusbDef	XIDef
8MT167-25BS1	25	mm	8MT167-25BS1.cfg	8MT167BS	28R	NoEnc	NoBrake	NoAcc	Buttons	NoAtten	XismusbDef	XIDef
8MT167-25BS1-MEn1	25	mm	8MT167-25BS1-MEn1.cfg	8MT167BS	28R	HEDM5500R	NoBrake	NoAcc	Buttons	NoAtten	XismusbDef	XIDef
8MT167-25LS	25	mm	8MT167-25LS.cfg	8MT167LS	28R	NoEnc	NoBrake	NoAcc	Buttons	NoAtten	XismusbDef	XIDef
8MT167-25LS-MEn1	25	mm	8MT167-25LS-MEn1.cfg	8MT167LS	28R	HEDM5500R	NoBrake	NoAcc	Buttons	NoAtten	XismusbDef	XIDef
8MT167M-25BS1	25	mm	8MT167M-25BS1.cfg	8MT167BS	28R	NoEnc	NoBrake	NoAcc	Buttons	NoAtten	XismusbDef	XIDef
8MT167M-25LS	25	mm	8MT167M-25LS.cfg	8MT167LS	28R	NoEnc	NoBrake	NoAcc	Buttons	NoAtten	XismusbDef	XIDef
8MT167S-25BS1	25	mm	8MT167S-25BS1.cfg	8MT167BS	28R	NoEnc	NoBrake	NoAcc	Buttons	NoAtten	XismusbDef	XIDef
8MT167S-25LS	25	mm	8MT167S-25LS.cfg	8MT167LS	28R	NoEnc	NoBrake	NoAcc	Buttons	NoAtten	XismusbDef	XIDef
8MT167S-25LS-MEn1	25	mm	8MT167S-25LS-MEn1.cfg	8MT167LS	28R	HEDM5500R	NoBrake	NoAcc	Buttons	NoAtten	XismusbDef	XIDef
8MT167SV-100-VSS42	100	mm	8MT167SV-100-VSS42.cfg	8MT167	VSS42-R	NoEnc	NoBrake	NoAcc	Buttons	NoAtten	XismusbDef	XIDef
8MT167V-100-VSS42	100	mm	8MT167V-100-VSS42.cfg	8MT167	VSS42-R	NoEnc	NoBrake	NoAcc	Buttons	NoAtten	XismusbDef	XIDef
8MT167MV-25LS-VSS42	25	mm	8MT167MV-25LS-VSS42.cfg	8MT167	VSS42-R	NoEnc	NoBrake	NoAcc	Buttons	NoAtten	XismusbDef	XIDef
8MT167SV-25LS-VSS42	25	mm	8MT167SV-25LS-VSS42.cfg	8MT167	VSS42-R	NoEnc	NoBrake	NoAcc	Buttons	NoAtten	XismusbDef	XIDef
8MT167V-25LS-VSS42	25	mm	8MT167V-25LS-VSS42.cfg	8MT167	VSS42-R	NoEnc	NoBrake	NoAcc	Buttons	NoAtten	XismusbDef	XIDef

8MT173 - Motorized Translation Stages

Update: 15 March 2018

Part number	Travel range	Units	Profile	Positioner	Motor	Encoder	Brake	Accessories	Peripherals	Attenuator	Controller	XILab
8MT173-10	10	mm	8MT173-10.cfg	8MT173	28R	NoEnc	NoBrake	NoAcc	Buttons	NoAtten	XismusbDef	XIDef
8MT173-10-MEn1	10	mm	8MT173-10-MEn1.cfg	8MT173	28R	HEDM5500R	NoBrake	NoAcc	Buttons	NoAtten	XismusbDef	XIDef
8MT173-20	20	mm	8MT173-20.cfg	8MT173	28R	NoEnc	NoBrake	NoAcc	Buttons	NoAtten	XismusbDef	XIDef
8MT173-20-E3	20	mm	8MT173-20-E3.cfg	8MT173	28R	RevS	NoBrake	NoAcc	Buttons	NoAtten	XismusbDef	XIDef
8MT173D-20-E3	20	mm	8MT173D-20-E3.cfg	8MT173	28R	RevS	NoBrake	NoAcc	Buttons	NoAtten	XismusbDef	XIDef
8MT173D2-20-E3	20	mm	8MT173D2-20-E3.cfg	8MT173	28R	RevS	NoBrake	NoAcc	Buttons	NoAtten	XismusbDef	XIDef
8MT173-20-50-E3	20	mm	8MT173-20-50-E3.cfg	8MT173	28R	RevS	NoBrake	NoAcc	Buttons	NoAtten	XismusbDef	XIDef
8MT173-20-1-28S-E3	20	mm	8MT173-20-1-28S-E3.cfg	8MT173	28S	RevS	NoBrake	NoAcc	Buttons	NoAtten	XismusbDef	XIDef
8MT173-20-E4	20	mm	8MT173-20-E4.cfg	8MT173	28R	RevS	NoBrake	NoAcc	Buttons	NoAtten	XismusbDef	XIDef
8MT173-20-MEn1	20	mm	8MT173-20-MEn1.cfg	8MT173	28R	HEDM5500R	NoBrake	NoAcc	Buttons	NoAtten	XismusbDef	XIDef
8MT173-25	25	mm	8MT173-25.cfg	8MT173	28R	NoEnc	NoBrake	NoAcc	Buttons	NoAtten	XismusbDef	XIDef
8MT173-25-MEn1	25	mm	8MT173-25-MEn1.cfg	8MT173	28R	HEDM5500R	NoBrake	NoAcc	Buttons	NoAtten	XismusbDef	XIDef
8MT173-30	30	mm	8MT173-30.cfg	8MT173	28R	NoEnc	NoBrake	NoAcc	Buttons	NoAtten	XismusbDef	XIDef
8MT173-30-MEn1	30	mm	8MT173-30-MEn1.cfg	8MT173	28R	HEDM5500R	NoBrake	NoAcc	Buttons	NoAtten	XismusbDef	XIDef
8MT173V-10-VSS42	10	mm	8MT173V-10-VSS42.cfg	8MT173V	VSS42-R	NoEnc	NoBrake	NoAcc	Buttons	NoAtten	XismusbDef	XIDef
8MT173V-20-VSS42	20	mm	8MT173V-20-VSS42.cfg	8MT173V	VSS42-R	NoEnc	NoBrake	NoAcc	Buttons	NoAtten	XismusbDef	XIDef
8MT173V-25-VSS42	25	mm	8MT173V-25-VSS42.cfg	8MT173V	VSS42-R	NoEnc	NoBrake	NoAcc	Buttons	NoAtten	XismusbDef	XIDef
8MT173V-30-VSS42	30	mm	8MT173V-30-VSS42.cfg	8MT173V	VSS42-R	NoEnc	NoBrake	NoAcc	Buttons	NoAtten	XismusbDef	XIDef

8MT173DC - Motorized Translation Stages

Update: 15 March 2018

Part number	Travel range	Units	Profile	Positioner	Motor	Encoder	Brake	Accessories	Peripherals	Attenuator	Controller	XILab
8MT173-10DCE2	10	mm	8MT173-10DCE2.cfg	8MT173-DCE2	Maxon-118512-R	EncMRtypeS-R	NoBrake	NoAcc	Buttons	NoAtten	XismusbDef	XIDefDC
8MT173-20DCE2	20	mm	8MT173-20DCE2.cfg	8MT173-DCE2	Maxon-118512-R	EncMRtypeS-R	NoBrake	NoAcc	Buttons	NoAtten	XismusbDef	XIDefDC
8MT173-25DCE2	25	mm	8MT173-25DCE2.cfg	8MT173-DCE2	Maxon-118512-R	EncMRtypeS-R	NoBrake	NoAcc	Buttons	NoAtten	XismusbDef	XIDefDC
8MT173-30DCE2	30	mm	8MT173-30DCE2.cfg	8MT173-DCE2	Maxon-118512-R	EncMRtypeS-R	NoBrake	NoAcc	Buttons	NoAtten	XismusbDef	XIDefDC

8MT50 - Motorized Translation Stages

Update: 15 March 2018

Part number	Travel range	Units	Profile	Positioner	Motor	Encoder	Brake	Accessories	Peripherals	Attenuator	Controller	XILab
8MT50-100BS1	100	mm	8MT50-100BS1.cfg	8MT50	4247R	NoEnc	NoBrake	NoAcc	Buttons	NoAtten	XismusbDef	XIDef
8MT50-100BS1-MEn1	100	mm	8MT50-100BS1-MEn1.cfg	8MT50	4247R	HEDM5500R	NoBrake	NoAcc	Buttons	NoAtten	XismusbDef	XIDef
8MT50-100XY	100	mm	8MT50-100XY.cfg	8MT50	4247R	NoEnc	NoBrake	NoAcc	Buttons	NoAtten	XismusbDef	XIDef
8MT50-100XYZ	100	mm	8MT50-100XYZ.cfg	8MT50	4247R	NoEnc	NoBrake	NoAcc	Buttons	NoAtten	XismusbDef	XIDef
8MT50-150BS1	150	mm	8MT50-150BS1.cfg	8MT50	4247R	NoEnc	NoBrake	NoAcc	Buttons	NoAtten	XismusbDef	XIDef
8MT50-150BS1-MEn1	150	mm	8MT50-150BS1-MEn1.cfg	8MT50	4247R	HEDM5500R	NoBrake	NoAcc	Buttons	NoAtten	XismusbDef	XIDef
8MT50-150XY	150	mm	8MT50-150XY.cfg	8MT50	4247R	NoEnc	NoBrake	NoAcc	Buttons	NoAtten	XismusbDef	XIDef
8MT50-150XYZ	150	mm	8MT50-150XYZ.cfg	8MT50	4247R	NoEnc	NoBrake	NoAcc	Buttons	NoAtten	XismusbDef	XIDef
8MT50-200BS1	200	mm	8MT50-200BS1.cfg	8MT50	4247R	NoEnc	NoBrake	NoAcc	Buttons	NoAtten	XismusbDef	XIDef
8MT50-200BS1-MEn1	200	mm	8MT50-200BS1-MEn1.cfg	8MT50	4247R	HEDM5500R	NoBrake	NoAcc	Buttons	NoAtten	XismusbDef	XIDef
8MT50-200XY	200	mm	8MT50-200XY.cfg	8MT50	4247R	NoEnc	NoBrake	NoAcc	Buttons	NoAtten	XismusbDef	XIDef
8MT50-200XYZ	200	mm	8MT50-200XYZ.cfg	8MT50	4247R	NoEnc	NoBrake	NoAcc	Buttons	NoAtten	XismusbDef	XIDef
8MT50Z-100BS1	100	mm	8MT50Z-100BS1.cfg	8MT50	ST4118-K2V17690	NoEnc	BRAKE-BKE-04-05	NoAcc	Buttons	NoAtten	XismusbDef	XIDef
8MT50Z-150BS1	150	mm	8MT50Z-150BS1.cfg	8MT50	ST4118-K2V17690	NoEnc	BRAKE-BKE-04-05	NoAcc	Buttons	NoAtten	XismusbDef	XIDef
8MT50Z-200BS1	200	mm	8MT50Z-200BS1.cfg	8MT50	ST4118-K2V17690	NoEnc	BRAKE-BKE-04-05	NoAcc	Buttons	NoAtten	XismusbDef	XIDef

8MT30 - Narrow Motorized Translation Stages**Update:** 15 March 2018

Part number	Travel range	Units	Profile	Positioner	Motor	Encoder	Brake	Accessories	Peripherals	Attenuator	Controller	XILab
8MT30-50	50	mm	8MT30-50.cfg	8MT30	28R	NoEnc	NoBrake	NoAcc	Buttons	NoAtten	XismusbDef	XIDef
8MT30-50-MEn1	50	mm	8MT30-50-MEn1.cfg	8MT30	28R	HEDM5500R	NoBrake	NoAcc	Buttons	NoAtten	XismusbDef	XIDef
8MT30-50DCE	50	mm	8MT30-50DCE.cfg	8MT30DC	Maxon-339152-R	EncMRtypeML-R	NoBrake	NoAcc	Buttons	NoAtten	XismusbDef	XIDefDC
8MT30V-50-VSS42	50	mm	8MT30V-50-VSS42.cfg	8MT30V	VSS42-R	NoEnc	NoBrake	NoAcc	Buttons	NoAtten	XismusbDef	XIDef
8MT30V-50DCE	50	mm	8MT30V-50DCE.cfg	8MT30VDC	FAULHABER-1524T006SR	IE2-16	NoBrake	NoAcc	Buttons	NoAtten	XismusbDef	XIDefDC

8MT175 - Motorized Translation Stages

Update: 15 March 2018

Part number	Travel range	Units	Profile	Positioner	Motor	Encoder	Brake	Accessories	Peripherals	Attenuator	Controller	XILab
8MT175-100	100	mm	8MT175-100.cfg	8MT175	4247R	NoEnc	NoBrake	NoAcc	Buttons	NoAtten	XismusbDef	XIDef
8MT175-100-E3	100	mm	8MT175-100-E3.cfg	8MT175	4247R	RevS	NoBrake	NoAcc	Buttons	NoAtten	XismusbDef	XIDef
8MT175-100-MEn1	100	mm	8MT175-100-MEn1.cfg	8MT175	4247R	HEDM5500R	NoBrake	NoAcc	Buttons	NoAtten	XismusbDef	XIDef
8MT175-150	150	mm	8MT175-150.cfg	8MT175	4247R	NoEnc	NoBrake	NoAcc	Buttons	NoAtten	XismusbDef	XIDef
8MT175-150-MEn1	150	mm	8MT175-150-MEn1.cfg	8MT175	4247R	HEDM5500R	NoBrake	NoAcc	Buttons	NoAtten	XismusbDef	XIDef
8MT175-200	200	mm	8MT175-200.cfg	8MT175	4247R	NoEnc	NoBrake	NoAcc	Buttons	NoAtten	XismusbDef	XIDef
8MT175-200-MEn1	200	mm	8MT175-200-MEn1.cfg	8MT175	4247R	HEDM5500R	NoBrake	NoAcc	Buttons	NoAtten	XismusbDef	XIDef
8MT175-50	50	mm	8MT175-50.cfg	8MT175	4247R	NoEnc	NoBrake	NoAcc	Buttons	NoAtten	XismusbDef	XIDef
8MT175-50-MEn1	50	mm	8MT175-50-MEn1.cfg	8MT175	4247R	HEDM5500R	NoBrake	NoAcc	Buttons	NoAtten	XismusbDef	XIDef
8MT175V-100-VSS42	100	mm	8MT175V-100-VSS42.cfg	8MT175V	VSS42-R	NoEnc	NoBrake	NoAcc	Buttons	NoAtten	XismusbDef	XIDef
8MT175V-150-VSS42	150	mm	8MT175V-150-VSS42.cfg	8MT175V	VSS42-R	NoEnc	NoBrake	NoAcc	Buttons	NoAtten	XismusbDef	XIDef
8MT175V-200-VSS42	200	mm	8MT175V-200-VSS42.cfg	8MT175V	VSS42-R	NoEnc	NoBrake	NoAcc	Buttons	NoAtten	XismusbDef	XIDef
8MT175V-50-VSS42	50	mm	8MT175V-50-VSS42.cfg	8MT175V	VSS42-R	NoEnc	NoBrake	NoAcc	Buttons	NoAtten	XismusbDef	XIDef

8MT177 - Motorized Translation Stage**Update:** 15 March 2018

Part number	Travel range	Units	Profile	Positioner	Motor	Encoder	Brake	Accessories	Peripherals	Attenuator	Controller	XILab
8MT177-100	100	mm	8MT177-100.cfg	8MT177	4247R	NoEnc	NoBrake	NoAcc	Buttons	NoAtten	XismusbDef	XIDef
8MT177-100-E4	100	mm	8MT177-100-E4.cfg	8MT177	4247R	RevS	NoBrake	NoAcc	Buttons	NoAtten	XismusbDef	XIDef
8MT177-100XY	100	mm	8MT177-100XY.cfg	8MT177	4247R	NoEnc	NoBrake	NoAcc	Buttons	NoAtten	XismusbDef	XIDef
8MT177-100XYZ	100	mm	8MT177-100XYZ.cfg	8MT177	4247R	NoEnc	NoBrake	NoAcc	Buttons	NoAtten	XismusbDef	XIDef
8MT177-100-28	100	mm	8MT177-100-28.cfg	8MT177	28R	NoEnc	NoBrake	NoAcc	Buttons	NoAtten	XismusbDef	XIDef
8MT177-100-28XY	100	mm	8MT177-100-28XY.cfg	8MT177	28R	NoEnc	NoBrake	NoAcc	Buttons	NoAtten	XismusbDef	XIDef
8MT177-100-28XYZ	100	mm	8MT177-100-28XYZ.cfg	8MT177	28R	NoEnc	NoBrake	NoAcc	Buttons	NoAtten	XismusbDef	XIDef

8MT184 - Motorized Translation Stage

Update: 15 March 2018

Part number	Travel range	Units	Profile	Positioner	Motor	Encoder	Brake	Accessories	Peripherals	Attenuator	Controller	XILab
8MT184-13	13	mm	8MT184-13.cfg	8MT184	20-Rev	NoEnc	NoBrake	NoAcc	Buttons	NoAtten	XismusbDef	XIDef
8MT184-13DC	13	mm	8MT184-13DC.cfg	8MT184DC	FAULHABER-1524T006SR	IE2-256	NoBrake	NoAcc	Buttons	NoAtten	XismusbDef	XIDefDC
8MT184-13XY	13	mm	8MT184-13XY.cfg	8MT184	20-Rev	NoEnc	NoBrake	NoAcc	Buttons	NoAtten	XismusbDef	XIDef
8MT184-13XYZ	13	mm	8MT184-13XYZ.cfg	8MT184	20-Rev	NoEnc	NoBrake	NoAcc	Buttons	NoAtten	XismusbDef	XIDef
8MT184V-13DC	13	mm	8MT184V-13DC.cfg	8MT184DCV	FAULHABER-1524T006SR	IE2-16	NoBrake	NoAcc	Buttons	NoAtten	XismusbDef	XIDefDC

8MT193 - Motorized Translation Stage

Update: 15 March 2018

Part number	Travel range	Units	Profile	Positioner	Motor	Encoder	Brake	Accessories	Peripherals	Attenuator	Controller	XILab
8MT193-100	100	mm	8MT193-100.cfg	8MT193	4247R	NoEnc	NoBrake	NoAcc	Buttons	NoAtten	XismusbDef	XIDef
8MT193-100-E4-DS	100	mm	8MT193-100-E4-DS.cfg	8MT193	4247R	RevS	NoBrake	NoAcc	Buttons	NoAtten	XismusbDef	XIDef

8MT200 - Motorized Translation Stages

Update: 15 March 2018

Part number	Travel range	Units	Profile	Positioner	Motor	Encoder	Brake	Accessories	Peripherals	Attenuator	Controller	XILab
8MT200-100	100	mm	8MT200-100.cfg	8MT200	4247R	NoEnc	NoBrake	NoAcc	Buttons	NoAtten	XismusbDef	XIDef

8MTF - Motorized XY Scanning Stage

Update: 15 March 2018

Part number	Travel range	Units	Profile	Positioner	Motor	Encoder	Brake	Accessories	Peripherals	Attenuator	Controller	XILab
8MTF-102LS05	102	mm	8MTF-102LS05.cfg	8MTF-102	28R	NoEnc	NoBrake	NoAcc	Buttons	NoAtten	XismusbDef	XIDef
8MTF-75LS05	75	mm	8MTF-75LS05.cfg	8MTF-75	28R	NoEnc	NoBrake	NoAcc	Buttons	NoAtten	XismusbDef	XIDef
8MTF-75LS1	75	mm	8MTF-75LS1.cfg	8MTF-75-2	28R	NoEnc	NoBrake	NoAcc	Buttons	NoAtten	XismusbDef	XIDef

8MTF2 - Motorized Fiber Coupling Stage

Update: 15 March 2018

Part number	Travel range	Units	Profile	Positioner	Motor	Encoder	Brake	Accessories	Peripherals	Attenuator	Controller	XILab
8MTF2	2	mm	8MTF2.cfg	8MTF2	28	NoEnc	NoBrake	NoAcc	Buttons	NoAtten	XismusbDef	XIDef

8MTFV - Motorized Translation Stage

Update: 15 March 2018

Part number	Travel range	Units	Profile	Positioner	Motor	Encoder	Brake	Accessories	Peripherals	Attenuator	Controller	XILab
8MTFV-75_40LS05-42.3	40	mm	8MTFV-75_40LS05-42.3.cfg	8MTFV	D423	NoEnc	NoBrake	NoAcc	Buttons	NoAtten	XismusbDef	XIDef

8MT60 - Motorized Translation Stage

Update: 15 March 2018

Part number	Travel range	Units	Profile	Positioner	Motor	Encoder	Brake	Accessories	Peripherals	Attenuator	Controller	XILab
8MT60-200	200	mm	8MT60-200.cfg	8MT60	4247R	NoEnc	NoBrake	NoAcc	Buttons	NoAtten	XismusbDef	XIDef
8MT60V-200	200	mm	8MT60V-200.cfg	8MT60V	VSS42-R	NoEnc	NoBrake	NoAcc	Buttons	NoAtten	XismusbDef	XIDef

Rotation Stages



8MR151 - Motorized Rotation Stages



8MR170 - Motorized Rotation Stages



8MR174 - Motorized Rotation Stage

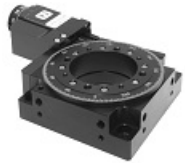

8MR190 - Motorized Rotation Stage



8MR191 - Motorized Rotation Stage



8MRB250 - Large Motorized Rotation Stage



8MRU - Universal Motorized Rotation Stages



8MPR16-1 - Motorized Polarizer Rotator



8MRH240 - Large High Capacity Rotary Stage

8MR151 - Motorized Rotation Stages**Update:** 15 March 2018

Part number	Travel range	Units	Profile	Positioner	Motor	Encoder	Brake	Accessories	Peripherals	Attenuator	Controller	XILab
8MR151-1	360	deg	8MR151-1.cfg	8MR151	28	NoEnc	NoBrake	NoAcc	Buttons	NoAtten	XismusbDef	XIDefRot
8MR151-1-MEn1	360	deg	8MR151-1-MEn1.cfg	8MR151	28	HEDM5500	NoBrake	NoAcc	Buttons	NoAtten	XismusbDef	XIDefRot
8MR151-30	360	deg	8MR151-30.cfg	8MR151	28	NoEnc	NoBrake	NoAcc	Buttons	NoAtten	XismusbDef	XIDefRot
8MR151-30-E4	360	deg	8MR151-30-E4.cfg	8MR151	28	RevS	NoBrake	NoAcc	Buttons	NoAtten	XismusbDef	XIDefRot
8MR151-30-MEn1	360	deg	8MR151-30-MEn1.cfg	8MR151	28	HEDM5500	NoBrake	NoAcc	Buttons	NoAtten	XismusbDef	XIDefRot
8MR151E-1	360	deg	8MR151E-1.cfg	8MR151	28	NoEnc	NoBrake	NoAcc	Buttons	NoAtten	XismusbDef	XIDefRot
8MR151E-30	360	deg	8MR151E-30.cfg	8MR151	28	NoEnc	NoBrake	NoAcc	Buttons	NoAtten	XismusbDef	XIDefRot
8MR151-30-E3	360	deg	8MR151-30-E3.cfg	8MR151	28	RevS	NoBrake	NoAcc	Buttons	NoAtten	XismusbDef	XIDefRot

8MR170 - Motorized Rotation Stages

Update: 15 March 2018

Part number	Travel range	Units	Profile	Positioner	Motor	Encoder	Brake	Accessories	Peripherals	Attenuator	Controller	XILab
8MR170-190	6	deg	8MR170-190.cfg	8MR170	28	NoEnc	NoBrake	NoAcc	Buttons	NoAtten	XismusbDef	XIDefRot

8MR174 - Motorized Rotation Stage

Update: 15 March 2018

Part number	Travel range	Units	Profile	Positioner	Motor	Encoder	Brake	Accessories	Peripherals	Attenuator	Controller	XILab
8MR174-11-20	360	deg	8MR174-11-20.cfg	8MR174	20	NoEnc	NoBrake	NoAcc	Buttons	NoAtten	XismusbDef	XIDefRot
8MR174-11-28	360	deg	8MR174-11-28.cfg	8MR174	28	NoEnc	NoBrake	NoAcc	Buttons	NoAtten	XismusbDef	XIDefRot
8MR174-11-28-E4	360	deg	8MR174-11-28-E4.cfg	8MR174	28	RevS	NoBrake	NoAcc	Buttons	NoAtten	XismusbDef	XIDefRot
8MR174-11-28S	360	deg	8MR174-11-28S.cfg	8MR174	28S	NoEnc	NoBrake	NoAcc	Buttons	NoAtten	XismusbDef	XIDefRot
8MR174-11-28-E3	360	deg	8MR174-11-28-E3.cfg	8MR174	28	RevS	NoBrake	NoAcc	Buttons	NoAtten	XismusbDef	XIDefRot
8MR174-11-28S-E3	360	deg	8MR174-11-28S-E3.cfg	8MR174	28S	RevS	NoBrake	NoAcc	Buttons	NoAtten	XismusbDef	XIDefRot
8MR174-11-28-MEn1	360	deg	8MR174-11-28-MEn1.cfg	8MR174	28	HEDM5500R	NoBrake	NoAcc	Buttons	NoAtten	XismusbDef	XIDefRot
8MR174E-11-20	360	deg	8MR174E-11-20.cfg	8MR174	20	NoEnc	NoBrake	NoAcc	Buttons	NoAtten	XismusbDef	XIDefRot
8MR174E-11-28	360	deg	8MR174E-11-28.cfg	8MR174	28	NoEnc	NoBrake	NoAcc	Buttons	NoAtten	XismusbDef	XIDefRot
8MR174E-11-28S	360	deg	8MR174E-11-28S.cfg	8MR174	28S	NoEnc	NoBrake	NoAcc	Buttons	NoAtten	XismusbDef	XIDefRot
8MR174E-11-28-MEn1	360	deg	8MR174E-11-28-MEn1.cfg	8MR174	28	HEDM5500R	NoBrake	NoAcc	Buttons	NoAtten	XismusbDef	XIDefRot
8MR174EV-11-VSS42	360	deg	8MR174EV-11-VSS42.cfg	8MR174V	VSS42	NoEnc	NoBrake	NoAcc	Buttons	NoAtten	XismusbDef	XIDefRot
8MR174V-11-VSS42	360	deg	8MR174V-11-VSS42.cfg	8MR174V	VSS42	NoEnc	NoBrake	NoAcc	Buttons	NoAtten	XismusbDef	XIDefRot

8MR190 - Motorized Rotation Stage

Update: 15 March 2018

Part number	Travel range	Units	Profile	Positioner	Motor	Encoder	Brake	Accessories	Peripherals	Attenuator	Controller	XILab
8MR190-2-28	360	deg	8MR190-2-28.cfg	8MR190	28	NoEnc	NoBrake	NoAcc	Buttons	NoAtten	XismusbDef	XIDefRot
8MR190-2-28-E4	360	deg	8MR190-2-28-E4.cfg	8MR190	28	RevS	NoBrake	NoAcc	Buttons	NoAtten	XismusbDef	XIDefRot
8MR190-2-WH-28-E3	360	deg	8MR190-2-WH-28-E3.cfg	8MR190	28	RevS	NoBrake	NoAcc	Buttons	NoAtten	XismusbDef	XIDefRot
8MR190-2-28-MEn1	360	deg	8MR190-2-28-MEn1.cfg	8MR190	28	HEDM5500	NoBrake	NoAcc	Buttons	NoAtten	XismusbDef	XIDefRot
8MR190-2-4233	360	deg	8MR190-2-4233.cfg	8MR190	4233	NoEnc	NoBrake	NoAcc	Buttons	NoAtten	XismusbDef	XIDefRot
8MR190-2-4247	360	deg	8MR190-2-4247.cfg	8MR190	4247R	NoEnc	NoBrake	NoAcc	Buttons	NoAtten	XismusbDef	XIDefRot
8MR190-2-ZSS43	360	deg	8MR190-2-ZSS43.cfg	8MR190	ZSS43	NoEnc	NoBrake	NoAcc	Buttons	NoAtten	XismusbDef	XIDefRot
8MR190V-2-VSS42	360	deg	8MR190V-2-VSS42.cfg	8MR190V	VSS42-R	NoEnc	NoBrake	NoAcc	Buttons	NoAtten	XismusbDef	XIDefRot
8MR190E-2-28	360	deg	8MR190E-2-28.cfg	8MR190	28	NoEnc	NoBrake	NoAcc	Buttons	NoAtten	XismusbDef	XIDefRot
8MR190E-2-28-E3	360	deg	8MR190E-2-28-E3.cfg	8MR190	28	RevS	NoBrake	NoAcc	Buttons	NoAtten	XismusbDef	XIDefRot
8MR190-2-28-E3	360	deg	8MR190-2-28-E3.cfg	8MR190	28	RevS	NoBrake	NoAcc	Buttons	NoAtten	XismusbDef	XIDefRot
8MR190E-2-4233	360	deg	8MR190E-2-4233.cfg	8MR190	4233	NoEnc	NoBrake	NoAcc	Buttons	NoAtten	XismusbDef	XIDefRot
8MR190E-2-4247	360	deg	8MR190E-2-4247.cfg	8MR190	4247R	NoEnc	NoBrake	NoAcc	Buttons	NoAtten	XismusbDef	XIDefRot
8MR190E-2-ZSS43	360	deg	8MR190E-2-ZSS43.cfg	8MR190	ZSS43	NoEnc	NoBrake	NoAcc	Buttons	NoAtten	XismusbDef	XIDefRot
8MR190EV-2-VSS42	360	deg	8MR190EV-2-VSS42.cfg	8MR190V	VSS42	NoEnc	NoBrake	NoAcc	Buttons	NoAtten	XismusbDef	XIDefRot
8MR190-90-59	360	deg	8MR190-90-59.cfg	8MR190-90-59	5918-R	NoEnc	NoBrake	NoAcc	Buttons	NoAtten	XismusbDef	XIDefRot
8MR190-90-59-MEn1	360	deg	8MR190-90-59-MEn1.cfg	8MR190-90-59	5918-R	HEDM5500R	NoBrake	NoAcc	Buttons	NoAtten	XismusbDef	XIDefRot
8MR190-90-4247	360	deg	8MR190-90-4247.cfg	8MR190-90-4247	4247R	NoEnc	NoBrake	NoAcc	Buttons	NoAtten	XismusbDef	XIDefRot
8MR190-90-4247-MEn1	360	deg	8MR190-90-4247-MEn1.cfg	8MR190-90-4247	4247R	HEDM5500R	NoBrake	NoAcc	Buttons	NoAtten	XismusbDef	XIDefRot
8MR190V-90-VSS43	360	deg	8MR190V-90-VSS43.cfg	8MR190-90-VSS43	VSS43	NoEnc	NoBrake	NoAcc	Buttons	NoAtten	XismusbDef	XIDefRot
8MR190-2-DCE	360	deg	8MR190-2-DCE.cfg	8MR190-2-DCE	Maxon-339152	EncMRtypeML	NoBrake	NoAcc	Buttons	NoAtten	XismusbDef	XIDefRot

8MR191 - Motorized Rotation Stage

Update: 15 March 2018

Part number	Travel range	Units	Profile	Positioner	Motor	Encoder	Brake	Accessories	Peripherals	Attenuator	Controller	XILab
8MR191-1-28	360	deg	8MR191-1-28.cfg	8MR191	28	NoEnc	NoBrake	NoAcc	Buttons	NoAtten	XismusbDef	XIDefRot
8MR191-1-4233	360	deg	8MR191-1-4233.cfg	8MR191	4233	NoEnc	NoBrake	NoAcc	Buttons	NoAtten	XismusbDef	XIDefRot
8MR191-1-4247	360	deg	8MR191-1-4247.cfg	8MR191	4247	NoEnc	NoBrake	NoAcc	Buttons	NoAtten	XismusbDef	XIDefRot
8MR191-1-ZSS43	360	deg	8MR191-1-ZSS43.cfg	8MR191	ZSS43	NoEnc	NoBrake	NoAcc	Buttons	NoAtten	XismusbDef	XIDefRot
8MR191-1-4209-E4	360	deg	8MR191-1-4209-E4.cfg	8MR191	4209	RevS	NoBrake	NoAcc	Buttons	NoAtten	XismusbDef	XIDefRot
8MR191-30-28	360	deg	8MR191-30-28.cfg	8MR191	28	NoEnc	NoBrake	NoAcc	Buttons	NoAtten	XismusbDef	XIDefRot
8MR191-30-4233	360	deg	8MR191-30-4233.cfg	8MR191	4233	NoEnc	NoBrake	NoAcc	Buttons	NoAtten	XismusbDef	XIDefRot
8MR191-30-4247	360	deg	8MR191-30-4247.cfg	8MR191	4247	NoEnc	NoBrake	NoAcc	Buttons	NoAtten	XismusbDef	XIDefRot
8MR191-30-4209-E4	360	deg	8MR191-30-4209-E4.cfg	8MR191	4209	RevS	NoBrake	NoAcc	Buttons	NoAtten	XismusbDef	XIDefRot
8MR191-30-ZSS43	360	deg	8MR191-30-ZSS43.cfg	8MR191	ZSS43	NoEnc	NoBrake	NoAcc	Buttons	NoAtten	XismusbDef	XIDefRot
8MR191-28	360	deg	8MR191-28.cfg	8MR191	28	NoEnc	NoBrake	NoAcc	Buttons	NoAtten	XismusbDef	XIDefRot
8MR191-4233	360	deg	8MR191-4233.cfg	8MR191	4233	NoEnc	NoBrake	NoAcc	Buttons	NoAtten	XismusbDef	XIDefRot
8MR191-4247	360	deg	8MR191-4247.cfg	8MR191	4247	NoEnc	NoBrake	NoAcc	Buttons	NoAtten	XismusbDef	XIDefRot
8MR191-ZSS43	360	deg	8MR191-ZSS43.cfg	8MR191	ZSS43	NoEnc	NoBrake	NoAcc	Buttons	NoAtten	XismusbDef	XIDefRot
8MR191E-1-28	360	deg	8MR191E-1-28.cfg	8MR191	28	NoEnc	NoBrake	NoAcc	Buttons	NoAtten	XismusbDef	XIDefRot
8MR191E-1-4233	360	deg	8MR191E-1-4233.cfg	8MR191	4233	NoEnc	NoBrake	NoAcc	Buttons	NoAtten	XismusbDef	XIDefRot
8MR191E-1-4247	360	deg	8MR191E-1-4247.cfg	8MR191	4247	NoEnc	NoBrake	NoAcc	Buttons	NoAtten	XismusbDef	XIDefRot
8MR191E-1-ZSS43	360	deg	8MR191E-1-ZSS43.cfg	8MR191	ZSS43	NoEnc	NoBrake	NoAcc	Buttons	NoAtten	XismusbDef	XIDefRot
8MR191E-30-28	360	deg	8MR191E-30-28.cfg	8MR191	28	NoEnc	NoBrake	NoAcc	Buttons	NoAtten	XismusbDef	XIDefRot
8MR191E-30-4233	360	deg	8MR191E-30-4233.cfg	8MR191	4233	NoEnc	NoBrake	NoAcc	Buttons	NoAtten	XismusbDef	XIDefRot
8MR191E-30-4247	360	deg	8MR191E-30-4247.cfg	8MR191	4247	NoEnc	NoBrake	NoAcc	Buttons	NoAtten	XismusbDef	XIDefRot
8MR191E-30-ZSS43	360	deg	8MR191E-30-ZSS43.cfg	8MR191	ZSS43	NoEnc	NoBrake	NoAcc	Buttons	NoAtten	XismusbDef	XIDefRot
8MR191E-28	360	deg	8MR191E-28.cfg	8MR191	28	NoEnc	NoBrake	NoAcc	Buttons	NoAtten	XismusbDef	XIDefRot
8MR191E-4233	360	deg	8MR191E-4233.cfg	8MR191	4233	NoEnc	NoBrake	NoAcc	Buttons	NoAtten	XismusbDef	XIDefRot
8MR191E-4247	360	deg	8MR191E-4247.cfg	8MR191	4247	NoEnc	NoBrake	NoAcc	Buttons	NoAtten	XismusbDef	XIDefRot

8MR191E-ZSS43	360	deg	8MR191E-ZSS43.cfg	8MR191	ZSS43	NoEnc	NoBrake	NoAcc	Buttons	NoAtten	XismusbDef	XIDefRot
8MR191V-1-VSS42	360	deg	8MR191V-1-VSS42.cfg	8MR191V	VSS42	NoEnc	NoBrake	NoAcc	Buttons	NoAtten	XismusbDef	XIDefRot
8MR191V-30-VSS42	360	deg	8MR191V-30-VSS42.cfg	8MR191V	VSS42	NoEnc	NoBrake	NoAcc	Buttons	NoAtten	XismusbDef	XIDefRot
8MR191V-VSS42	360	deg	8MR191V-VSS42.cfg	8MR191V	VSS42	NoEnc	NoBrake	NoAcc	Buttons	NoAtten	XismusbDef	XIDefRot
8MR191EV-1-VSS42	360	deg	8MR191EV-1-VSS42.cfg	8MR191V	VSS42	NoEnc	NoBrake	NoAcc	Buttons	NoAtten	XismusbDef	XIDefRot
8MR191EV-30-VSS42	360	deg	8MR191EV-30-VSS42.cfg	8MR191V	VSS42	NoEnc	NoBrake	NoAcc	Buttons	NoAtten	XismusbDef	XIDefRot
8MR191EV-VSS42	360	deg	8MR191EV-VSS42.cfg	8MR191V	VSS42	NoEnc	NoBrake	NoAcc	Buttons	NoAtten	XismusbDef	XIDefRot

8MRB - Large Motorized Rotation Stage**Update:** 15 March 2018

Part number	Travel range	Units	Profile	Positioner	Motor	Encoder	Brake	Accessories	Peripherals	Attenuator	Controller	XILab
8MRB240-152-59	360	deg	8MRB240-152-59.cfg	8MRB240	5918	NoEnc	NoBrake	NoAcc	Buttons	NoAtten	XismusbDef	XIDefRot
8MRB240-152-59D	360	deg	8MRB240-152-59D.cfg	8MRB240	5918	NoEnc	NoBrake	NoAcc	Buttons	NoAtten	XismusbDef	XIDefRot
8MRB450-350-60-MEn2	360	deg	8MRB450-350-60-MEn2.cfg	8MRB450	6018	WEDL5541-B	NoBrake	NoAcc	Buttons	NoAtten	XismusbDef	XIDefRot

8MRU - Universal Motorized Rotation Stages

Update: 15 March 2018

Part number	Travel range	Units	Profile	Positioner	Motor	Encoder	Brake	Accessories	Peripherals	Attenuator	Controller	XILab
8MRU-1	360	deg	8MRU-1.cfg	8MRU	28S	NoEnc	NoBrake	NoAcc	Buttons	NoAtten	XismusbDef	XIDefRot
8MRU-1TP	360	deg	8MRU-1TP.cfg	8MRU	28S	NoEnc	NoBrake	NoAcc	Buttons	NoAtten	XismusbDef	XIDefRot
8MRU-1WA	360	deg	8MRU-1WA.cfg	8MRU	28S	NoEnc	NoBrake	NoAcc	Buttons	WA	XismusbDef	XIDefRot

8MPR16-1 - Motorized Polarizer Rotator**Update:** 15 March 2018

Part number	Travel range	Units	Profile	Positioner	Motor	Encoder	Brake	Accessories	Peripherals	Attenuator	Controller	XILab
8MPR16-1-F	360	deg	8MPR16-1-F.cfg	8MPR16	FAULHABER-AM1020-V-3-16	NoEnc	NoBrake	NoAcc	Buttons	NoAtten	XismusbDef	XIDefRot

8MRH240 - Large High Capacity Rotary Stage

Update: 15 March 2018

Part number	Travel range	Units	Profile	Positioner	Motor	Encoder	Brake	Accessories	Peripherals	Attenuator	Controller	XILab
8MRH240-60	360	deg	8MRH240-60.cfg	8MRH240	5918	NoEnc	NoBrake	NoAcc	Buttons	NoAtten	XismusbDef	XIDefRot

Vertical Translation Stages



8MVT100 - Vertical Translation Stage



8MVT120 - Vertical Translation Stage



8MVT188 - Vertical Translation Stage



8MVT40 - Vertical Translation Stage



8MVT70 - Vertical Translation Stage

8MVT100 - Vertical Translation Stage

Update: 15 March 2018

Part number	Travel range	Units	Profile	Positioner	Motor	Encoder	Brake	Accessories	Peripherals	Attenuator	Controller	XILab
8MVT100-25-1	26	mm	8MVT100-25-1.cfg	8MVT100	4118L1804R	NoEnc	NoBrake	NoAcc	Buttons	NoAtten	XismusbDef	XIDef

8MVT120 - Vertical Translation Stage

Update: 15 March 2018

Part number	Travel range	Units	Profile	Positioner	Motor	Encoder	Brake	Accessories	Peripherals	Attenuator	Controller	XILab
8MVT120-5-4247	5	mm	8MVT120-5-4247.cfg	8MVT120-5	4247R	NoEnc	NoBrake	NoAcc	Buttons	NoAtten	XismusbDef	XIDef
8MVT120-12-4247	12.7	mm	8MVT120-12-4247.cfg	8MVT120-12	4247R	NoEnc	NoBrake	NoAcc	Buttons	NoAtten	XismusbDef	XIDef
8MVT120-25-4247	25.4	mm	8MVT120-25-4247.cfg	8MVT120-25	4247R	NoEnc	NoBrake	NoAcc	Buttons	NoAtten	XismusbDef	XIDef

8MVT188 - Vertical Translation Stage

Update: 15 March 2018

Part number	Travel range	Units	Profile	Positioner	Motor	Encoder	Brake	Accessories	Peripherals	Attenuator	Controller	XILab
8MVT188-20	8744052	steps	8MVT188-20.cfg	8MVT188	5918	NoEnc	NoBrake	NoAcc	Buttons	NoAtten	XismusbDef	XIDef

8MVT40 - Vertical Translation Stage

Update: 15 March 2018

Part number	Travel range	Units	Profile	Positioner	Motor	Encoder	Brake	Accessories	Peripherals	Attenuator	Controller	XILab
8MVT40-13-1	13	mm	8MVT40-13-1.cfg	8MVT40	28SR	NoEnc	NoBrake	NoAcc	Buttons	NoAtten	XismusbDef	XIDef

8MVT70 - Vertical Translation Stage

Update: 15 March 2018

Part number	Travel range	Units	Profile	Positioner	Motor	Encoder	Brake	Accessories	Peripherals	Attenuator	Controller	XILab
8MVT70-13-1	13	mm	8MVT70-13-1.cfg	8MVT70	4118S1404R	NoEnc	NoBrake	NoAcc	Buttons	NoAtten	XismusbDef	XIDef

Screws and Actuators



8MS00 - Motorized Screws



8CMA06 - Motorized Actuator



8CMA20 - Compact Motorized Actuator



8CMA28 - Motorized Linear Actuator



8CMA16DC - Motorized Linear Actuator

8MS00 - Motorized Screws**Update:** 15 March 2018

Part number	Travel range	Units	Profile	Positioner	Motor	Encoder	Brake	Accessories	Peripherals	Attenuator	Controller	XILab
8MS00-10	10	mm	8MS00-10.cfg	8MS00-10	4233-R	NoEnc	NoBrake	NoAcc	Buttons	NoAtten	XismusbDef	XIDef
8MS00-10-28	10	mm	8MS00-10-28.cfg	8MS00-10	28R	NoEnc	NoBrake	NoAcc	Buttons	NoAtten	XismusbDef	XIDef
8MS00-25	25	mm	8MS00-25.cfg	8MS00-25	4233-R	NoEnc	NoBrake	NoAcc	Buttons	NoAtten	XismusbDef	XIDef
8MS00-25-28	25	mm	8MS00-25-28.cfg	8MS00-25	28R	NoEnc	NoBrake	NoAcc	Buttons	NoAtten	XismusbDef	XIDef
8MS00V-10-VSS43	10	mm	8MS00V-10-VSS43.cfg	8MS00V-10	VSS43-R	NoEnc	NoBrake	NoAcc	Buttons	NoAtten	XismusbDef	XIDef
8MS00V-25-VSS43	25	mm	8MS00V-25-VSS43.cfg	8MS00V-25	VSS43-R	NoEnc	NoBrake	NoAcc	Buttons	NoAtten	XismusbDef	XIDef

8CMA06 - Motorized Actuator**Update:** 15 March 2018

Part number	Travel range	Units	Profile	Positioner	Motor	Encoder	Brake	Accessories	Peripherals	Attenuator	Controller	XILab
8CMA06-13_10	13	mm	8CMA06-13_10.cfg	8CMA06-13	20-Rev	NoEnc	NoBrake	NoAcc	Buttons	NoAtten	XismusbDef	XIDef
8CMA06-13_15	13	mm	8CMA06-13_15.cfg	8CMA06-13	20-Rev	NoEnc	NoBrake	NoAcc	Buttons	NoAtten	XismusbDef	XIDef
8CMA06-25_15	25	mm	8CMA06-25_15.cfg	8CMA06-25	20-Rev	NoEnc	NoBrake	NoAcc	Buttons	NoAtten	XismusbDef	XIDef

8CMA20 - Compact Motorized Actuator

Update: 15 March 2018

Part number	Travel range	Units	Profile	Positioner	Motor	Encoder	Brake	Accessories	Peripherals	Attenuator	Controller	XILab
8CMA20-8_15	8	mm	8CMA20-8_15.cfg	8CMA20	20-Rev	NoEnc	NoBrake	NoAcc	Buttons	NoAtten	XismusbDef	XIDef

8CMA28 - Motorized Linear Actuator

Update: 15 March 2018

Part number	Travel range	Units	Profile	Positioner	Motor	Encoder	Brake	Accessories	Peripherals	Attenuator	Controller	XILab
8CMA28-10	10	mm	8CMA28-10.cfg	8CMA28	28R	NoEnc	NoBrake	NoAcc	Buttons	NoAtten	XismusbDef	XIDef

8CMA16DC - Motorized Linear Actuator**Update:** 15 March 2018

Part number	Travel range	Units	Profile	Positioner	Motor	Encoder	Brake	Accessories	Peripherals	Attenuator	Controller	XILab
8CMA16DC-13_15	13	mm	8CMA16DC-13_15.cfg	8CMA16DC	FAULHABER-1524T006SR	IE2-256	NoBrake	NoAcc	Buttons	NoAtten	XismusbDef	XIDefDC
8CMA16DC-25_15	25	mm	8CMA16DC-25_15.cfg	8CMA16DC	FAULHABER-1524T006SR	IE2-256	NoBrake	NoAcc	Buttons	NoAtten	XismusbDef	XIDefDC
8CMA16DCV-13_15	13	mm	8CMA16DCV-13_15.cfg	8CMA16DCV	FAULHABER-1524T006SR	IE2-16	NoBrake	NoAcc	Buttons	NoAtten	XismusbDef	XIDefDC
8CMA16DCV-25_15	25	mm	8CMA16DCV-25_15.cfg	8CMA16DCV	FAULHABER-1524T006SR	IE2-16	NoBrake	NoAcc	Buttons	NoAtten	XismusbDef	XIDefDC

Motorized Goniometers



8MG00 - Motorized Goniometers



8MG99 - Motorized Goniometer

8MG00 - Motorized Goniometers**Update:** 15 March 2018

Part number	Travel range	Units	Profile	Positioner	Motor	Encoder	Brake	Accessories	Peripherals	Attenuator	Controller	XILab
8MG00-50	0.5	deg	8MG00-50.cfg	8MG00-50	4233-R	NoEnc	NoBrake	NoAcc	Buttons	NoAtten	XismusbDef	XIDef
8MG00-80	0.5	deg	8MG00-80.cfg	8MG00-80	4233-R	NoEnc	NoBrake	NoAcc	Buttons	NoAtten	XismusbDef	XIDef
8MG00V-50	0.5	deg	8MG00V-50.cfg	8MG00-50	VSS42-R	NoEnc	NoBrake	NoAcc	Buttons	NoAtten	XismusbDef	XIDef
8MG00V-80	0.5	deg	8MG00V-80.cfg	8MG00-80	VSS42-R	NoEnc	NoBrake	NoAcc	Buttons	NoAtten	XismusbDef	XIDef

8MG99 - Motorized Goniometer**Update:** 15 March 2018

Part number	Travel range	Units	Profile	Positioner	Motor	Encoder	Brake	Accessories	Peripherals	Attenuator	Controller	XILab
8MG99-50	0.5	deg	8MG99-50.cfg	8MG99-50	4233-R	NoEnc	NoBrake	NoAcc	Buttons	NoAtten	XismusbDef	XIDef
8MG99-80	0.5	deg	8MG99-80.cfg	8MG99-80	4233-R	NoEnc	NoBrake	NoAcc	Buttons	NoAtten	XismusbDef	XIDef
8MG99V-50	0.5	deg	8MG99V-50.cfg	8MG99-50	VSS42-R	NoEnc	NoBrake	NoAcc	Buttons	NoAtten	XismusbDef	XIDef
8MG99V-80	0.5	deg	8MG99V-80.cfg	8MG99-80	VSS42-R	NoEnc	NoBrake	NoAcc	Buttons	NoAtten	XismusbDef	XIDef

Mirror Mounts



8MTOM2 - Motorized Two Axis Translation Optical Mount



8MUP21 - Motorized Optical Mount



8MBM24 - Motorized Mirror Mounts



8MMA60 - Motorized Mirror Mounts



8MBM57 - Large Aperture Motorized Mirror Mount



8MKVDOM - Motorized Vertical drive optical mount

8MTOM2 - Motorized Two Axis Translation Optical Mount

Update: 15 March 2018

Part number	Travel range	Units	Profile	Positioner	Motor	Encoder	Brake	Accessories	Peripherals	Attenuator	Controller	XILab
8MTOM2-1	4	mm	8MTOM2-1.cfg	8MTOM2	20	NoEnc	NoBrake	NoAcc	Buttons	NoAtten	XismusbDef	XIDef

8MUP21 - Motorized Optical Mount

Update: 15 March 2018

Part number	Travel range	Units	Profile	Positioner	Motor	Encoder	Brake	Accessories	Peripherals	Attenuator	Controller	XILab
8MUP21-2	4	mm	8MUP21-2.cfg	8MUP21	20-Rev	NoEnc	NoBrake	NoAcc	Buttons	NoAtten	XismusbDef	XIDef

8MBM24 - Motorized Mirror Mounts

Update: 15 March 2018

Part number	Travel range	Units	Profile	Positioner	Motor	Encoder	Brake	Accessories	Peripherals	Attenuator	Controller	XILab
8MBM24-1-2	4	mm	8MBM24-1-2.cfg	8MBM24	20-Rev	NoEnc	NoBrake	NoAcc	Buttons	NoAtten	XismusbDef	XIDef
8MBM24-2-2	4	mm	8MBM24-2-2.cfg	8MBM24	20-Rev	NoEnc	NoBrake	NoAcc	Buttons	NoAtten	XismusbDef	XIDef
8MBM24-3-2	4	mm	8MBM24-3-2.cfg	8MBM24	20-Rev	NoEnc	NoBrake	NoAcc	Buttons	NoAtten	XismusbDef	XIDef

8MMA60 - Motorized Mirror Mounts

Update: 15 March 2018

Part number	Travel range	Units	Profile	Positioner	Motor	Encoder	Brake	Accessories	Peripherals	Attenuator	Controller	XILab
8MMA60-1	5	deg	8MMA60-1.cfg	8MMA60	4233	NoEnc	NoBrake	NoAcc	Buttons	NoAtten	XismusbDef	XIDef
8MMA60-2	5	deg	8MMA60-2.cfg	8MMA60	4233	NoEnc	NoBrake	NoAcc	Buttons	NoAtten	XismusbDef	XIDef
8MMA60-40	5	deg	8MMA60-40.cfg	8MMA60	4233	NoEnc	NoBrake	NoAcc	Buttons	NoAtten	XismusbDef	XIDef

8MBM57 - Large Aperture Motorized Mirror Mount**Update:** 15 March 2018

Part number	Travel range	Units	Profile	Positioner	Motor	Encoder	Brake	Accessories	Peripherals	Attenuator	Controller	XILab
8MBM57-2	5	deg	8MBM57-2.cfg	8MBM57	28	NoEnc	NoBrake	NoAcc	Buttons	NoAtten	XismusbDef	XIDef
8MBM57-3	5	deg	8MBM57-3.cfg	8MBM57	28	NoEnc	NoBrake	NoAcc	Buttons	NoAtten	XismusbDef	XIDef
8MBM57-4	5	deg	8MBM57-4.cfg	8MBM57	28	NoEnc	NoBrake	NoAcc	Buttons	NoAtten	XismusbDef	XIDef
8MBM57-6	5	deg	8MBM57-6.cfg	8MBM57	28	NoEnc	NoBrake	NoAcc	Buttons	NoAtten	XismusbDef	XIDef

8MKVDOM - Motorized Vertical drive optical mount**Update:** 15 March 2018

Part number	Travel range	Units	Profile	Positioner	Motor	Encoder	Brake	Accessories	Peripherals	Attenuator	Controller	XILab
8MKVDOM-1	6	mm	8MKVDOM-1.cfg	8MKVDOM	20	NoEnc	NoBrake	NoAcc	Buttons	NoAtten	XismusbDef	XIDef
8MKVDOM-2	6	mm	8MKVDOM-2.cfg	8MKVDOM	28	NoEnc	NoBrake	NoAcc	Buttons	NoAtten	XismusbDef	XIDef

Motorized Attenuators



10MCWA168 - Motorised Closed Variable Wheel Attenuator



10MWA168 - Motorized Variable Wheel Attenuator

10MCWA168 - Motorised Closed Variable Wheel Attenuator**Update:** 15 March 2018

Part number	Travel range	Units	Profile	Positioner	Motor	Encoder	Brake	Accessories	Peripherals	Attenuator	Controller	XILab
10MCWA168-1	360	deg	10MCWA168-1.cfg	10MCWA168	4247	RevS	NoBrake	NoAcc	Buttons	WA168	XismusbDef	XIDef
10MCWA168-20	360	deg	10MCWA168-20.cfg	10MCWA168	4247	RevS	NoBrake	NoAcc	Buttons	WA168	XismusbDef	XIDef

10MWA168 - Motorized Variable Wheel Attenuator**Update:** 15 March 2018

Part number	Travel range	Units	Profile	Positioner	Motor	Encoder	Brake	Accessories	Peripherals	Attenuator	Controller	XILab
10MWA168-1	360	deg	10MWA168-1.cfg	10MWA168	4247ROT	NoEnc	NoBrake	NoAcc	Buttons	WA168	XismusbDef	XIDef
10MWA168-20	360	deg	10MWA168-20.cfg	10MWA168	4247ROT	NoEnc	NoBrake	NoAcc	Buttons	WA168	XismusbDef	XIDef

Motorized Iris Diaphragms



8MID98 - Motorized Iris Diaphragm

8MID98 - Motorized Iris Diaphragm

Update: 15 March 2018

Part number	Travel range	Units	Profile	Positioner	Motor	Encoder	Brake	Accessories	Peripherals	Attenuator	Controller	XILab
8MID98-4-90	93	mm	8MID98-4-90.cfg	8MID98-4-90	28	NoEnc	NoBrake	NoAcc	Buttons	NoAtten	XismusbDef	XIDef
8MID98-4-H	94	mm	8MID98-4-H.cfg	8MID98	28	NoEnc	NoBrake	NoAcc	Buttons	NoAtten	XismusbDef	XIDef
8MID98-4-N	94	mm	8MID98-4-N.cfg	8MID98	28	NoEnc	NoBrake	NoAcc	Buttons	NoAtten	XismusbDef	XIDef

7.2. Software

Full XIMC software package for Windows, last updated: 02.03.2018

Includes latest versions of XILab user interface application for Windows only, libximc library development kit, firmware binary and user manual.

Download full software package. Disconnect all controllers from the PC. Launch XILab installer. Full installation manual can be found [here](#).

XILab, 1.14.8, last updated 15.02.2018

XILab can be downloaded here:

Windows XP, Vista, 7, 8, 10	xilab-1.14.8-win32_win64.exe
Generic Linux 32 bit	xilab-1.14.8-ia32.AppImage
Generic Linux 64 bit	xilab-1.14.8-x86_64.AppImage
MacOS X	xilab-1.14.8-osx64.tar.gz

[All XILab versions](#)
[Compatibility table](#)
[XILab changelog](#)

Development kit, 2.9.12, last updated 15.02.2018

Download and extract: [libximc-2.9.12-all.tar.gz](#)

Development kit manual may be found [here](#) and in the /docs-en/index.html development kit file. Library is located in /ximc-2.9.12 and examples are in /examples.

PDF-version of the development kit manual can be downloaded [here](#)

[All libximc versions](#)
[Compatibility table](#)
[Libximc changelog](#)

Controller firmware

Download for 8SMC5: [ximc-4.1.8-hw2.3.x.cod](#), last updated 12.01.2018

Download for 8SMC4: [ximc-3.9.18-hw2.2.x.cod](#), last updated 06.06.2017

Firmware update instructions:

1. Download firmware file.
2. Start XILab
3. It is recommended to make a backup of your XILab configuration file before firmware update.
4. Open "Settings... -> Device configuration -> About device", press "Update" button, select new firmware file, press "Open".
5. XILab might stop responding for a while. Please wait while firmware is being uploaded, it should take about 10-15 seconds.
6. If settings have changed then load your configuration file and save it to the controller flash memory by pressing "Save to flash" button.

[All firmware versions](#)
[Compatibility table](#)
[Firmware changelog](#)

Configuration files

Configuration files may be found [here](#).

LabView examples

Labview examples can be downloaded here: [labview-2.9.12-Labview_12.0.7z](#)

Drivers

On Windows controller doesnt need additional drivers, however you need an inf-file for the controller to be recognized by the operating system. It will be automatically installed with XILab. It can be found in "C:\Program Files\XILab\Driver" after installation. Also you may download it here: [XIMC_driver.inf](#)

Linux and MacOS do not require driver files.

Software for 8SMC1-USBhF controllers with 8SMC4-USB support

Software may be downloaded here: [microsmc-2.3.0-win32_win64.zip](#)
 Detailed information is available [here](#).

Firmware for USB-Ethernet adapter, 1.1.0, last updated 11.07.2016

The software can be downloaded here: [cubian-1.1.0-armhf.7z](#)
 Detailed information is available [here](#).

All Firmware USB-Ethernet adapter versions
 Firmware changelog

REVEALER, 0.1.0, last updated 16.04.2017

The software can be downloaded here:

Windows XP, Vista, 7, 8, 10	☐ revealer-0.1.0-win32.zip
Linux 32-bit	☐ revealer-0.1.0-lin32.tar.gz
Linux 64-bit	☐ revealer-0.1.0-lin64.tar.gz
MacOS	☐ revealer-0.1.0-osx64.zip
Java	☐ revealer-0.1.0-j.jar

Detailed information is available [here](#).

All REVEALER versions
 REVEALER changelog

All XILab versions

Version	Windows XP, Vista, 7, 8, 10	MacOS X	Generic Linux 32-bit	Generic Linux 64-bit	Debian/Ubuntu 32-bit	Debian/Ubuntu 64-bit	RedHat/OpenSUSE 64-bit	RedHat/OpenSUSE 32-bit
1.14.8	☐ Download	☐ Download	☐ Download	☐ Download	-	-	-	-
1.14.7	☐ Download	☐ Download	☐ Download	☐ Download	-	-	-	-
1.14.5	☐ Download	☐ Download	☐ Download	☐ Download	-	-	-	-
1.13.14	☐ Download	☐ Download	-	-	☐ Download	☐ Download	☐ Download	☐ Download
1.13.13	☐ Download	☐ Download	-	-	☐ Download	☐ Download	☐ Download	☐ Download
1.12.18	☐ Download	☐ Download	-	-	☐ Download	☐ Download	☐ Download	☐ Download
1.12.15	☐ Download	☐ Download	-	-	☐ Download	☐ Download	☐ Download	☐ Download
1.12.14	☐ Download	☐ Download	-	-	☐ Download	☐ Download	☐ Download	☐ Download
1.12.13	☐ Download	☐ Download	-	-	☐ Download	☐ Download	☐ Download	☐ Download
1.12.10	☐ Download	☐ Download	-	-	☐ Download	☐ Download	☐ Download	☐ Download
1.12.8	☐ Download	☐ Download	-	-	☐ Download	☐ Download	☐ Download	☐ Download
1.11.12	☐ Download	☐ Download	-	-	☐ Download	☐ Download	☐ Download	☐ Download
1.11.10	☐ Download	☐ Download	-	-	☐ Download	☐ Download	☐ Download	-
1.10.14	☐ Download	☐ Download	-	-	☐ Download	☐ Download	☐ Download	-
1.10.11	☐ Download	☐ Download	-	-	☐ Download	☐ Download	☐ Download	-
1.10.10	☐ Download	☐ Download	-	-	☐ Download	☐ Download	☐ Download	-
1.10.6	☐ Download	☐ Download	-	-	☐ Download	☐ Download	☐ Download	-
1.9.18	☐ Download	☐ Download	-	-	☐ Download	☐ Download	☐ Download	-
1.9.17	☐ Download	☐ Download	-	-	☐ Download	☐ Download	☐ Download	-
1.9.16	☐ Download	☐ Download	-	-	☐ Download	☐ Download	☐ Download	-
1.9.15	☐ Download	☐ Download	-	-	☐ Download	☐ Download	☐ Download	-
1.9.14	☐ Download	☐ Download	-	-	☐ Download	☐ Download	☐ Download	-
1.9.13	☐ Download	☐ Download	-	-	☐ Download	☐ Download	☐ Download	-
1.9.12	☐ Download	☐ Download	-	-	☐ Download	☐ Download	☐ Download	-
1.9.11	☐ Download	☐ Download	-	-	☐ Download	☐ Download	☐ Download	-
1.8.30	☐ Download	☐ Download	-	-	☐ Download	☐ Download	☐ Download	-
1.8.29	☐ Download	☐ Download	-	-	☐ Download	☐ Download	☐ Download	-
1.8.28	☐ Download	☐ Download	-	-	☐ Download	☐ Download	☐ Download	-

XILab changelog

[View...](#)

All libximc, MicroSMC and XIMC_Labview versions

Версия	Libximc	Libximc sources	XIMC_Labview	MicroSMC
2.9.12	Download	Download	Download for Labview 12.0	-
2.9.11	Download	-	Download for Labview 12.0	-
2.9.8	Download	-	-	-
2.8.10	Download	-	-	-
2.8.9	Download	-	-	-
2.8.8	Download	-	-	-
2.8.7	Download	-	-	-
2.8.5	Download	-	Download for Labview 11.0 Download for Labview 12.0 Download for Labview 8.2	-
2.8.4	Download	-	Download for Labview 12.0	-
2.8.0	Download	-	Download for Labview 12.0 Download for Labview 8.0	-
2.3.2	Download	-	-	-
2.3.1	Download	-	-	-
2.3.0	Download	-	Download for Labview 12.0 Download for Labview 8.6	Download
2.2.2	Download	-	Download for Labview 12.0	Download
2.2.1	Download	-	Download for Labview 12.0	Download
2.2.0	Download	-	-	-
2.0.5	Download	-	-	-

Officially supported Labview 12.0, other versions are re-saving with compatibility for earlier versions (not tested)

The build instruction for libximc-src is in the libximc archive in the ximc\doc-en folder

Libximc changelog

[View...](#)

XIMC_Labview changelog

[View...](#)

Microsmc changelog

[View...](#)

All firmware versions

Version 8SMC4)	(for File	Version 8SMC5)	(for File
3.9.18	Download	4.1.8	Download
3.9.16	Download	4.1.6	Download
3.9.14	Download	4.1.5	Download
3.9.12	Download	4.1.4	Download
3.9.11	Download	4.0.9	Download
3.9.10	Download	4.0.7	Download
3.9.9	Download	4.0.4	Download
3.9.8	Download		
3.9.7	Download		
3.9.5	Download		
3.8.19	Download		
3.8.17	Download		
3.8.16	Download		
3.8.14	Download		
3.8.11	Download		
3.8.10	Download		
3.8.9	Download		
3.8.8	Download		
3.8.7	Download		
3.8.4	Download		
3.8.3	Download		

Firmware changelog

[View...](#)

Compatibility table

Protocol version	XILab	libximc	firmware
16.3	1.8.28-1.8.30	2.0.5	3.8.3-3.8.4
16.6	1.9.11-1.9.18	2.2.1-2.2.2	3.8.7-3.8.11
16.6	1.10.6-1.10.14	2.3.0-2.3.2	3.8.7-3.8.11
16.8	1.11.10-1.11.12	2.5.0	3.9.5-3.9.8
16.8	1.12.7-1.12.8	2.8.0	3.9.5-3.9.8
16.10	1.12.10	2.8.4-2.8.5	3.9.9
16.10	1.12.13	2.8.7	3.9.10-3.9.11
16.11	1.12.14	2.8.8-2.8.9	3.9.12
16.12	1.12.15	2.8.10	3.9.14
16.12	1.12.18	2.8.10-2.8.12	3.9.14-3.9.16
17.2	1.13.13-1.13.14	2.9.8-2.9.12	3.9.16-3.9.18, 4.0.4-4.0.9
18.1	1.14.5-1.14.8	2.10.3	4.1.4-4.1.8

All firmware versions for USB-Ethernet adapter

Version	File
1.1.0	Download
1.0.0	Download

Detailed information is available [here](#).

Firmware changelog

[View...](#)

All REVEALER versions for USB-Ethernet adapter

Version	Linux x32	Linux x64	Mac OS	Windows	Java
0.1.0	Download	Download	Download	Download	Download

REVEALER changelog

[View...](#)

8. Related products

1. [Ethernet adapter](#)

8.1. Control via Ethernet

1. [Overview](#)
2. [Administration](#)

8.1.1. Ethernet adapter Overview

General information



Outward appearance of 8SMC4-USB-Eth1 adapter

8SMC4-USB-Eth1¹ is a universal device based on Cubieboard2 single-board computer with OS Linux inside, which enables the end user to interact with motor controllers remotely via various Ethernet-oriented interfaces. This device is also intended to be a universal provider for different services related to controllers' popular usage scenarios (e.g. motion control). It means that if there is a standalone program which could be effectively used in conjunction with our controllers, chances are high that this adapter already has it preconfigured and all you need is to plug some controllers and connect Ethernet cable to it. Out-of-the-box **8SMC4-USB-Eth1** supports online web-camera streaming, LAN auto-discovery system and two interfaces to configure and control motor controllers:

1. [TANGO](#) control system interface.
2. XiLab- and libximc-oriented [XIMC](#) interface.

Moreover **8SMC4-USB-Eth1** is equipped with embedded web-based [administration interface](#), which enables the end user to conveniently control the device and monitor its state.

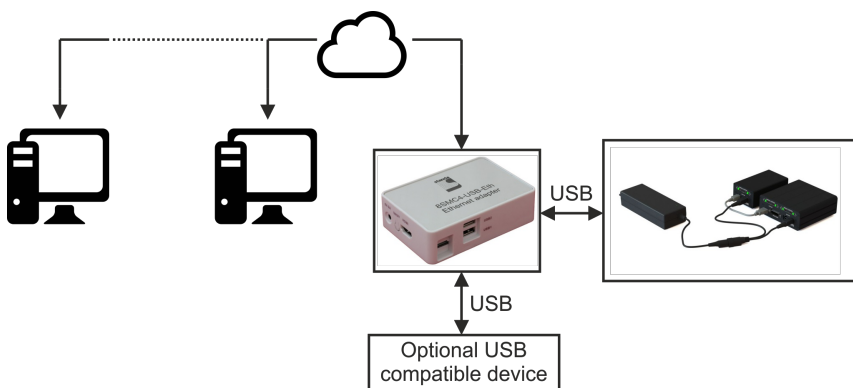

The appearance of the system from different perspectives (all necessary connectors in current version are marked with bold):



Front view. Left to right: **power connector**, **on/off switch**, **HDMI connector**.



View from the right. Left to right: **micro-SD card connector**, **two USB type A female connectors**.



Back view. Left to right: **Ethernet connector**, **mini-USB type B**, **switch to transfer into FEL mode**, **earphone and line in connectors**.



View from the left. **IR receiver**.

Main requirements

Network configuration

- You must have a DHCP server that supports an automatic distribution of ip addresses.
- Server and your computer must support IPv4 protocol.
- Port 49150 should not be blocked. The cause of blocking can often be the presence of antivirus software, or program which monitors and filters network traffic (firewalls).

Other

- 220V socket should be available.
- Ethernet cable, USB cable.

¹ The vendor code was changed in 2017, earlier this product had the vendor code 8SMC4-USB-Eth.

8.1.2. Administration

Note. Administration interface and [TANGO](#) support might not be present in your version of the device. You can update the device firmware using our [instruction](#).

Automatic device detection

As a convenience we provide a small dedicated utility called "Revealer" in order to help you instantly identify all the **Standa 8SMC4-USB-Eth1** adapters connected to your local network. You can download it from our [software page](#).

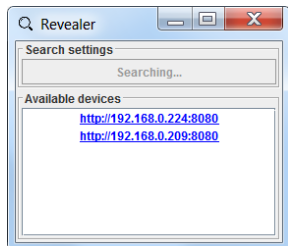

"Revealer" utility interface

The Graphical User Interface of the "Revealer" is a simple one. In order to start search click [Search](#) button on [Search settings](#) panel - the scan takes approximately 3 seconds. After that all **Standa 8SMC4-USB-Eth1** devices found in your local network will be listed on [Available devices](#) panel as clickable links. When clicked, the link opens your default system browser and redirects it to Administration interface web page.

The utility requires Java Runtime Environment (or simply JRE) version 6 or greater to work. There are high chances that you already have it installed on your PC as it's the requirement for a great number of popular software packages and so you just need to double-click the "revealer-j_0.1.0.jar" file to launch the utility.

Otherwise it means that you don't have JRE installed and have two options:

1. Download our ready-made packages for your operating system containing the "Revealer" utility and all the stuff necessary to make it work. In this case you just need to launch "Revealer" executable.
2. Install JRE. A good candidate is Oracle JRE which you can install following the [official instructions](#).



Warning. "Revealer" uses UDP broadcasts to reach all **Standa 8SMC4-USB-Eth1** in your LAN so it might be unusable in the environments where UDP broadcasts are forbidden or unwanted.

Overview

Standa 8SMC4-USB-Eth1 device is equipped with web-based Administration interface which enables the end user to control device services and monitor system state.

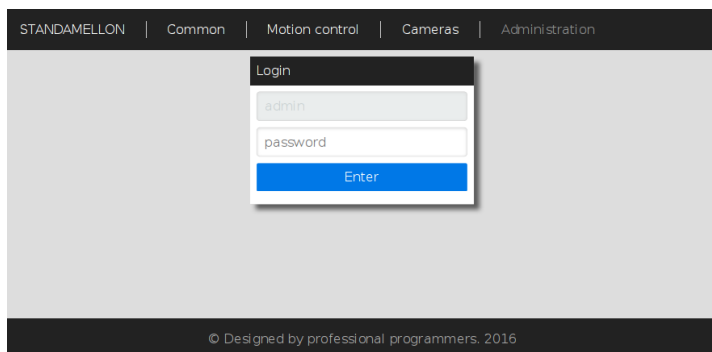

Administration interface login page

In order to get access to the Administration panel, navigate your browser to [http://\[address\]](#) URL (where *[address]* should be replaced with IP address of the device in your local network and can be obtained with the help of "Revealer" utility). If you are doing this for the first time (or you've disabled cookies/password storage in your browser) you'll need to authenticate yourself using "admin" as login and password.

Note. It's highly recommended to enable javascript in your browser while using Administration interface to get the best user experience.

Note. Web-interface is compatible with MS IE 9, MS IE 10, MS IE 11, MS Spartan, Firefox, Chrome browsers and might not work as expected in others.

Administration interface is split into three functional sections.

"Common" section

System Info		Connected Controllers	
Uptime	0:05:41	#	Serial number
IP address	172.16.1.171	1	32
MAC address	02:05:05-41:f2:8b		

Common section page

This section contains generic system information and decimal serial numbers of all controllers connected to the device.

"Motion control" section

Motion control section page

This section is dedicated to motion control services supported by the device. "Motion Control services" panel contains a list of all currently available motion control services. Clicking on services' title opens an appropriate settings panel (or none if service has no alterable settings). Clicking "Apply" button in settings panel will persist settings in database and restart corresponding service.

Note. Motion control services are mutually exclusive - only one can be active at any given moment. Starting one of the services will automatically stop previous active if any.

"Cameras" section

Cameras section page

In this section there is a list of all connected cameras. Each camera is associated with streaming server instance, which exposes settings, status indicators and controls.

Service control

The Administration panel enables you to control all available device services. There is a common management metaphor for all services independent of its' actual functionality and aim. Each service has an associated Indicator button on the left of its title which shows current services's status and enables changing it:

- Red color with "Stopped" label indicates that service is completely stopped; pressing the button will run service startup.
- Orange color with "Starting" label indicates that service is in interruptible start sequence; pressing the button will revert service to stopped state.
- Green color with "Stop" label shows that the service is up and running; pressing the button will trigger service stop sequence.
- Orange color with "Stopping" label indicates uninterruptible stop sequence.

Note. Many services have settings which can be altered. After changing any of such settings the corresponding process will be automatically restarted shortly - the Indicator button will show it dynamically.

Firmware upgrade



Warning. During the update MicroSD content and 8SMC4-USB-Eth1 device flash memory will be wiped out. Make sure that you've made necessary backups.

1. Download an appropriate firmware version from [software page](#).
2. Get a 4GB (or larger) MicroSD card.
3. Download and unpack an autoinstaller image archive. On Windows family operating system you might have no appropriate archiver — in this case you may use 7-Zip ([official site](#)).
4. Put the image onto the MicroSD card:
 - Unix family OS:
 1. You can do it via dd utility (e.g.

```
dd if=autoinstall_image_2015-12-17.bin of=/dev/sdX bs=4M; sync
```

but remember to substitute the device names with yours).

- Windows family OS:
 1. Download [Win32 Disk Imager](#) ([official site](#)) and start it.
 2. Specify autoinstaller image path in "Image File" field.
 3. Select your MicroSD drive in "Device" list.
 4. Press "Write" button and wait till progressbar completes.
5. Insert the microSD card with the image into your **8SMC4-USB-Eth1** and turn it on (or reboot).
 6. Wait approximately 10 minutes to let the firmware be installed. You may check the progress of installation by looking at LED indicator inside the case of the device through USB plugs:
 1. LED is stable green or emits periodic single green pulses - autoinstaller is initializing.
 2. LED periodically emits green double pulses - installation is in progress.
 3. LED is stable green - installation is complete.
 7. Power off the device (just plug the power cable off) and extract MicroSD card.
 8. Power on the device and wait another 2-7 minutes to let the device initialize itself.



Warning. On some rare occasions the device might not be visible through the [revealer](#)(and have its services and administration interface unavailable either) even well after estimated initialization period. In this case try to reboot the device. If it doesn't help try to redo steps from 5 to 8.

Now you should have your **8SMC4-USB-Eth1** device updated and fully operational.

Troubleshooting



Warning. If your device won't work properly, leds don't blink as described above during flashing and your device manufactured **after 2017 October**, please, contact support.

Uninitialized Cubieboard2 bootloader

In some rare cases the steps described in Firmware upgrade instruction might not succeed. One of the possible reasons is that due to some technical failure the Cubieboard2 singleboard computer bootloader (on which **8SMC4-USB-Eth1** is based on) was not properly

initialized. However bootloader initialization isn't very complicated:

1. Download [PhoenixSuit](#) ([official site](#)) and unpack it;
2. Download [Lubuntu server image with bootloader supporting SoC A20 rev.B](#) for PhoenixSuit ([official site](#), "Firmwares" -> "Cubieboard2" -> "Lubuntu Server") and unpack it.
3. Start PhoenixSuit. In case of update request, confirm it and wait till it's done.
4. Switch to "Firmware" tab and specify unpacked Lubuntu server image path.
5. Power off the device. Press and hold FEL button (it's near LAN and USB-OTG connectors). While still holding the button, connect USB-OTG to your PC and then release the button.
6. You might need to explicitly install driver for the device on Windows family OS.
 1. Navigate to the Device Manager.
 2. Locate "Unknown Device" and right click on it.
 3. In the context menu press "Update driver software...".
7. Specify "PhoenixSuit1.0.7\PhoenixSuit\Drivers\AW_Driver" as driver search directory.
8. After that a popup in PhoenixSuite will appear. Press "YES (Full install)" and wait for the completion.
9. Continue to autoinstall instruction.